

**Makita**®



**2020.10**  
**GENERAL CATALOGUE**  
KATALOG PRODUK 综合产品目录



**XGT**

**40V** *Li-ion*  
**max**





18V Lithium-ion



Teknologi Ekstrim Litium-ion  
鋰离子技术

Rear Handle Saw

Recipro Saw

Slide Compound Miter Saw

Rotary Hammer

Stapler

Concrete Vibrator

Pin Nailer

Finish Nailer

Combination Hammer

Portable Cut-off

Shear Wrench

Angle Drill

Inflator

Fan

LED Worklight

LED Flashlight

Flashlight

Flashlight Radio

Area Worklight

Fan Jacket

Heated Blanket

Fan Vest

Heated Jacket

Heated Vest

Coffee Maker

Job Site Radio

Job Site Speaker

Blower

Chain Saw

Hedge Trimmer

Robotic Cleaner

Trimmer

Grass Shear

Vacuum Cleaner

Grass Trimmer

Portable Vacuum Cleaner

Planer

Drywall Saw

String Trimmer

Cleaner

Cut-Out Tool

Cyclone Cleaner

Plate Joiner

Jig Saw

# 18V LITHIUM-ION

18V Lithium-ion | 18V 锂离子



## 18V x2 320+ TOOLS

6.0Ah 5.0Ah 4.0Ah  
3.0Ah 2.0Ah 1.5Ah

Expand Your Lithium Line Up

# INDEX Indeks 索引

<b>CORDLESS</b> Tanpa Kord 充电式	26 - 113	4327	201	AT638A	208	<b>DCL280FZW / ZB / Z</b> <span style="color:red">NEW</span>	127
<b>LED FLASHLIGHT</b> Lampu Suluh LED LED照明灯	114 - 118	4327M	201	<b>B</b>		DCL281FZW / ZB / Z	127
<b>VACUUM CLEANER</b> Pembersih Vakum 吸尘器	119 - 151	4329	200	BBC231URDE / Z   BC231UDWBE	102	DCL500Z	124
<b>DRILLING   FASTENING</b> Gerudi   Pengetat 钻孔   紧固	152 - 157	4350CT	200	BBC300LRDE	102	DCL501Z	124
<b>IMPACT DRILLING   DEMOLITION</b> Gerudi   Pemecah 石工钻孔   凿壁加工	158 - 168	4351CT	200	BHR262RB3	101	DCM501Z	108
<b>CUTTING</b> Pematong 切割	169 - 175	4403	206	BHX2500	219	DCO180Z	79
<b>GRINDING   SANDING</b> Pengisar   Pelicin 研削   研磨	176 - 194	<b>5</b>		BML360Z	102	DCS231T	216
<b>SAWING</b> Gergaji 锯切	195 - 202	5008MG	198	BO3710	193	DCS520-53	215
<b>PLANING   ROUTERING</b> Pengetam   Tanggam 刨削   雕刻	203 - 206	5016B	214	BO4510H	193	DCS550RFE / Z	61
<b>OTHERS</b> Lain-lain 其他	207 - 210	5103N	199	BO4556	194	DCS551RFJ / Z	61
<b>OUTDOOR POWER EQUIPMENT</b> Alatan Kerja Luar 园林·户外	211 - 223	5402	199	BO4901	193	DCS552Z	61
<b>Makita</b> mt	224 - 233	5806B	198	BO5031	194	DCS553Z	61
<b>1</b>		<b>6</b>		BO5041	194	DCS6401-50	215
1805N	204	6016	153	BO6050J	194	DCS7301-60	215
1911B	203	6271DWE	103	BUC250RD	101	DCS7901-70	216
<b>2</b>		6305	152	BUH550RD / Z   UH550DWB	101	DCS9010-76	216
2012NB	204	6413	152	BUH650RD / Z   UH650DWB	102	DCU180Z	86
2107F	173	6905B	156	BUN490RD	102	DCV202YXL	112
2416S	174	6906	156	<b>C</b>		DDA351Z	55
2704	197	6922NB	157	CA5000X	175	DDA460ZK	33
2712	197	6924N	157	CB100DB	113	DDF083RTE / RFE / Z	47
<b>3</b>		<b>9</b>		CC300DW / Z	98	DDF453RME / RFE / SYE / Z	47
3501N	204	9031	192	CC301DWMW / WAE / Z	93	DDF458RME / RFE / Z	46
3600H	206	9035H	193	CF100DZ	107	DDF459RME / Z	47
3612BR	206	9045B	193	CF101DZ	107	DDF481RTE / RME / RFE / Z	46
3709	205	9215SB	187	CG100DZA	94	DDF482RME / RFE / Z	46
3901	205	9237C	187	CL070DZ	131	DDF483RTE / RME / RFE / Z	47
<b>4</b>		9401	192	CL100DW / Z	130	DDF484RTE / RME / RFE / Z	46
4100KB	170	9404	191	CL102DW / Z	130	DDF485RFE / Z	46
4100NH	170	9553HBG	176	CL104DWYX / WY	130	DF001DW	100
4100NH2Z	170	9553HNG	176	CL105DW / WX	130	DF001GD201 <span style="color:red">NEW</span>	26
4100NH3Z	170	9556HNG / HN / NB	177	CL106FDWYW / ZW	129	DF012DSE	99
4107R	170	9556HPG / PB	177	CL107FDWYW / ZW	129	DF0300 <span style="color:red">NEW</span>	152
4112HS	169	9557HNG / NBG	179	CL108FDWYW / ZW	129	DF030DWE	97
4114S	169	9557HPG	179	CL111DWI / WR	130	DF031DSME / WAE / WYE / Z	88
4131	169	9558HNG / NBG	181	CL121DZ	129	DF032DSME / SAE / Z	87
4190DW	103	9558HPG	181	CL183DZX	131	DF033DSME / WAE / Z	87
4300BV	201	9563C	178	CP100DWA / Z	92	DF330DWE	97
		9565CR / PC	182	<b>D</b>		DF331DSME / Z	87
		9903	192	DA3010F	154	DF332DSME / SAE / Z	87
		9911	192	DA332DWAE / Z	91	DF333DSME / WAE / Z	87
		9924DB	192	DBO180Z	74	DFJ201ZM / ZL / ZXL	112
		<b>A</b>		DCB200B	113	DFJ202ZL / ZXL	111
		ADP05	107	DCF102Z	106	DFJ211ZM / ZL / ZXL	110
		ADP06	108	DCF201Z	106	DFJ212ZM / ZL / ZXL	111
		ADP08	108	DCF203Z	106	DFJ213ZM / ZL / ZXL	111
		AF353	207	DCG180RFE / RFEB / ZB / Z	86	DFJ214ZM / ZL / ZXL	110
		AF506	207	DCL180FRFW / RFB / ZB / Z	128	DFJ300ZXL	111
		AF601	207	DCL181FZWX	128	DFJ311ZM / ZL / ZXL	110
		AF635	207	DCL182FRFW / FZW	128	DFJ400ZXL	112

**Double Insulation**  
Penebat Berganda | 双重绝缘

**Variable Speed**  
Kelajuan Boleh Ubah | 无段变速

**Brake**  
Brek | 电子自动刹车

**Reversing**  
Mengundur | 正逆转

**Electronic Ignition**  
Penyalan Elektronik | 电子式启动装置

**Mechanical 2-Speed**  
2-kelajuan Mekanikal | 机械式双速

**Electronic 2-Speed**  
2-kelajuan Elektronik | 电子式双速

**Electronic 3-Speed**  
3-kelajuan Elektronik | 电子式三速

**Electronic 4-Speed**  
4-kelajuan Elektronik | 电子式四速

**Keyless Chuck**  
Chuck Pengetatan Diri | 自锁夹头

**Torque Setting 6**  
Pelarasan Tork 6 | 6档扭力调整

**Torque Setting 9**  
Pelarasan Tork 9 | 9档扭力调整

**Torque Setting 16**  
Pelarasan Tork 16 | 16档扭力调整

**Torque Setting 18**  
Pelarasan Tork 18 | 18档扭力调整

**Torque Setting 20**  
Pelarasan Tork 20 | 20档扭力调整

DFJ411ZM / ZL / ZXL	110	DHS630RME / RFE / Z	75	DPO500Z	71	DUB182Z	85
DFN350Z	80	DHS661RFJ / Z	75	DPO600Z	71	DUB183Z	85
DFR550Z	55	DHS680RMJ / RFJ / Z	75	DPP200ZK / Z <b>NEW</b>	63	DUB184RT / Z <b>NEW</b>	85
DFS250RTE / RFE / Z	55	DHS710RM2J / RF2J	36	DPT353Z	80	DUB361Z	44
DFS251RTE / RFE / Z	55	DHS782Z	37	DRC200Z	124	DUB362RM2 / Z	44
DFS452Z	55	DHS783Z	37	DRS780Z	36	DUB363ZV <b>NEW</b>	44
DFV210ZM / ZL / ZXL	111	DHS900PT2 / Z <b>NEW</b>	37	DRT50Z / ZJX9	79	DUC122RME / Z	84
DGA402RFE / Z	68	DHW080ZK	45	DRV150Z	62	DUC252PM4 / Z	43
DGA404RTE / RFE / Z	68	DJN161Z	62	DRV250Z	62	DUC254Z	84
DGA405RFE / Z	68	DJR181RFE	76	DS4012	153	DUC353Z	43
DGA406RME / RFE / Z	67	DJR183Z	76	DS5000	153	DUC355Z	42
DGA408RME / RFE / Z	67	DJR186RME / RFE / Z	76	DSC102ZJ <b>NEW</b>	64	DUC356Z <b>NEW</b>	42
DGA411Z	67	DJR187RME / RFE / Z	76	DSC121ZK	64	DUC406Z	42
DGA414Z	67	DJR188Z	76	DSC162Z	64	DUH523RME / RFE / Z	81
DGA418Z	67	DJR360RF4 / Z	36	DSC163ZK	64	DUH601Z	81
DGA419Z <b>NEW</b>	66	DJS101Z	62	DSC191Z	65	DUH651Z	43
DGA452RME / RFE / Z	69	DJS130RFE / Z	62	DSC251ZK	65	DUH754SRT / Z <b>NEW</b>	81
DGA456RFE / Z	68	DJS161Z	62	DSD180Z	77	DUM168Z	84
DGA458RFE / Z	68	DJV180RFE / Z	77	DSL800Z	72	DUM604Z	84
DGA505RFE / Z	70	DJV181RFE / Z	77	DSP600Z	35	DUN500WZ <b>NEW</b>	82
DGA508RFE / Z	70	DJV182RME / RFE / Z	77	DSP601Z	35	DUN600LZ <b>NEW</b>	82
DGA511Z	70	DKP180RFE / Z	78	DSS501Z	75	DUP361Z	39
DGA514Z	70	DKP181RTJ / Z <b>NEW</b>	78	DSS610Z	75	DUP362ZN	39
DGA518Z	70	DLM380Z	41	DST221Z	80	DUR181Z	84
DGA519Z <b>NEW</b>	69	DLM382PT2 / Z <b>NEW</b>	41	DTD149RFE / Z	53	DUR182LRF / Z	83
DGA700Z	34	DLM431PT2 / Z	41	DTD152RME / RFE / Z	53	DUR184LZ	83
DGA701Z	34	DLM432PT2 / Z <b>NEW</b>	41	DTD153RTE / RFE / Z	53	DUR187LRF / Z	83
DGA900Z	34	DLM460Z	41	DTD154RME / RFE / Z	53	DUR188LRF / Z	83
DGA901Z	34	DLM532Z <b>NEW</b>	40	DTD155RME / Z	54	DUR188URFE	83
DGD800Z	71	DLS111Z	35	DTD156SF / Z <b>NEW</b>	53	DUR189Z	82
DGD801Z	71	DLS211Z	35	DTD170RME / RFE / Z	52	DUR190LRT2 <b>NEW</b>	82
DHK180Z <b>NEW</b>	60	DLS600Z	74	DTD171RTJ / RFJ / Z	52	DUR364LPM4 / RM2 / Z	38
DHP453RME / RFE / SYE / Z	50	DLS713RME / Z	74	DTL061Z	54	DUR368APT2 / Z	39
DHP458RME / RFE / Z	49	DLS714PM2 / Z	35	DTL062Z	103	DUR368LPT2 / Z	39
DHP459Z	50	DLW140Z	36	DTL063Z	59	DUR369LZ <b>NEW</b>	38
DHP481RTE / RFE / Z	49	DML186	117	DTM50Z	73	DUT130RFE / Z	61
DHP482RME / RFE / RFX1 / Z	49	DML801	116	DTM51RFEX8 / Z	73	DUT131Z	61
DHP483RME / RFE / Z	50	DML802	116	DTP141RFE / Z	54	DUX60ZM3 / Z	43
DHP484RME / RFE / Z	49	DML805	117	DTR180ZJ	63	DVC150LZ	120
DHP485RFE / Z	49	DML808	115	DTS141RFE / Z	54	DVC151LZ	120
DHR165RME / RFE / Z	60	DML807 <b>NEW</b>	115	DTW152Z	103	DVC152LZ	120
DHR171RTE / RFE / Z	60	DML810 <b>NEW</b>	115	DTW180Z	58	DVC153LZ	120
DHR182ZWJ	59	DML812 <b>NEW</b>	116	DTW181RFE / Z	58	DVC154LZ / ZX	121
DHR202RME / RFE / Z	59	DMP180Z <b>NEW</b>	86	DTW190RME / RFE / Z	58	DVC155LZX3 <b>NEW</b>	121
DHR241RFE / Z	59	DMR114 <b>NEW</b>	105	DTW251RME / RFE / Z	58	DVC157LZX5 <b>NEW</b>	121
DHR242RTE / RME / RFE / Z	59	DMR203 <b>NEW</b>	105	DTW285RME / RFE / Z	57	DVC260Z / ZX	122
DHR263PM4 / RF4 / Z	33	DP2010	152	DTW450RME / RFE / Z	57	DVC261Z	122
DHR280PT2J / Z	32	DPB180Z	65	DTW800RMJ / RFJ / Z	57	DVC265ZX <b>NEW</b>	122
DHR282PT2J / Z	32	DPB182Z	65	DTW1001RTJ / RMJ / RFJ / Z	57	DVC350Z	128
DHR400ZKN	32	DPJ180Z	79	DTW1002RTJ / RMJ / RFJ / Z	57	DVC660Z <b>NEW</b>	123

 **Torque Setting 21**  
Pelarasan Tork 21 | 21档扭力调整

 **SDS-PLUS Shank**  
Batang SDS-PLUS | 四坑柄

 **SDS-MAX Shank**  
Batang SDS-MAX | 五坑柄

 **17mm Hex Shank**  
Batang Heksagon 17mm | 17mm六角柄

 **30mm Hex Shank**  
Batang Heksagon 30mm | 30mm六角柄

 **21mm Hex Shank**  
Batang Heksagon 21mm | 21mm六角柄

 **28.6mm Hex Shank**  
Batang Heksagon 28.6mm | 28.6mm六角柄

 **Torque Limiter**  
Pengehad Tork | 扭力限制器 (安全离合器)

 **Constant Speed**  
Kelajuan Tetap | 电子定速

 **Soft Start**  
Penghidupan Secara Perlahan | 缓速起动

















 **Bevel Cutting L45 R5**  
Pemotongan Serong Kiri 45° Kanan 5° | 斜角切割(左45°/右5°)

 **Bevel Cutting 45 left**  
Pemotongan Serong Kiri 45° | 斜角切割(左45°)

 **Bevel Cutting 45 LR**  
Pemotongan Serong Kiri Kanan 45° | 斜角切割(左右各45°)

 **Orbital Cutting**  
Pemotongan Orbit | 轨道切割

 **Makita Shank Jig Saw Blade**  
Bilah Gergaji Ukir Makita | M型式锯片

DVC665Z 	123	FS2300	154	GB801	190	HR2470X5	160
DVC750LZ / ZX1	128	FS2500	154	GD0600	188	HR2611FT	160
DVC860LZ	121	FS2700	155	GD0601	188	HR2630X3	160
DVC862LPT2 / RT2 / Z	122	FS4200	155	GD0603	189	HR2631FTX2	160
DVC863LPT2 / RT2 / Z	122	FS6300	155	GD0800C	189	HR2652	161
DVC864LZ	121	<b>G</b>		GD0801C	189	HR2810	161
DVF154Z	86	GA003GM201 / D201 	29	GD0811C	189	HR3200C	161
DVP180Z	79	GA005GM201 / D201 	30	GS5000	189	HR3210C	161
DVR450Z	86	GA011GM201 / D201 	29	GS6000	190	HR3530	162
DWT310ZK	33	GA013GM201 / D201 	30	GV5010	187	HR4001C	162
<b>E</b>		GA021GM201 / D201 / Z 	29	GV6010	187	HR4002	162
EA3110T30B	216	GA023GM201 / D201 / Z 	30	GV7000C	187	HR4003C	162
EA3201S40B	214	GA027GM201 / D201 / Z 	30	<b>H</b>		HR4013C	162
EA3502S40B	214	GA029GM201 / D201 / Z 	30	HB500	157	HR4030C	163
EA4301F45B	214	GA4030	177	HG5030K	209	HR4501C	163
EA5600F53G	216	GA4030R	176	HG6031VK	209	HR4511C	163
EA6100P	215	GA4031	177	HG6530VK	208	HR5202C	163
EA7900P70E	215	GA4034	177	HG6531CK	209	HR5211C	163
EB5300TH	219	GA4040	178	HK1820	166	HR5212C	164
EB7660TH	218	GA4040C	178	HM0810TA	164	HS004GM201 / Z 	31
EBH340R	212	GA4041C	178	HM0870C	164	HS0600	199
EBH340U	211	GA4530	179	HM0871C	164	HS100	210
EE2650H	212	GA4530R	179	HM1201	165	HS300DW	98
EH5000W	217	GA4540	180	HM1203C	165	HS301DSME / WAE / Z	93
EH6000W	217	GA4540R	179	HM1213C	165	HS6100	197
EH7500SX	217	GA4541C	180	HM1214C	165	HS6600	198
EK6101	221	GA5010	181	HM1306	165	HS7010	198
EK7301	221	GA5020	181	HM1307C	166	HS7600	198
EK7651H / X1	221	GA5030	180	HM1317C	166	HTR5600	218
ELM3311X	220	GA5030R	180	HM1810	166	HTR7610	218
ELM3320	220	GA5034	181	HM1812	166	HW102	223
ELM3711X	220	GA5040	182	HP001GD201 	26	HW121	223
ELM3720	220	GA5041C	182	HP0300 	158	HW1200	223
ELM4121	220	GA6010	182	HP1230	158	HW1300	223
EM2600U	212	GA6020C	183	HP1630	158	<b>J</b>	
EM2654LH	211	GA6040	183	HP2050	159	JN1601	174
EM3400L	212	GA7020	184	HP330DWE	97	JN3201	174
EM3400U	211	GA7040R	185	HP331DSME / WAE / WYE	88	JR001GM201 / Z 	31
EM4350RH	212	GA7050	183	HP332DSME / SAE / Z	88	JR100DWE	99
EN4951SH	218	GA7060	184	HP333DSME / WAE / Z	88	JR102DWE	99
ETR2500	213	GA7060R	184	HR001GM201 	28	JR105DWAE / Z	94
EW2051H	223	GA7061R	184	HR002GM201 	28	JR3050T	201
EW3051H	223	GA7062	184	HR003GM201 / Z 	28	JR3051TK 	201
EX2650LHM	213	GA7063R	183	HR140DWYE1	91	JR3070CT	202
EY2650H25H	217	GA9020	186	HR166DSMJ / WAJ / Z	91	JS1300	175
<b>F</b>		GA9050	185	HR1830	159	JS1601	175
FJ203DZL / DZLL	111	GA9060	186	HR1840	159	JS1602	175
FJ301DZM / DZL / DZLL	111	GA9060R	185	HR1841F	159	JS3201	175
FJ401DZL / DZLL / DZ3L	112	GA9061R	185	HR2020	159	JV0600K	200
FJ502DZM / ZL / ZLL	110	GB602	190	HR2320T / X2	160	JV100DWE	98

 **Bayonet Shank Jig Saw Blade**  
Bilah Gergaji Ukir Jenis Bayonet | B型曲线锯锯片

 **Anti Vibration**  
Anti Getaran | 防震

 **Capacitor Discharge Ignition**  
Pencucuhan Nyahas Kapasitor | 电容放电式点火

 **Laser Marker**  
Penanda Laser | 雷射标志

 **Automatic Oiling**  
Fungsi Pelinciran Automatik | 自动润滑功能

 **Decompression Valve**  
Injap Penyahmampatan | 减压阀

 **Hook & Loop**  
Strap Velcro | 魔术贴式





 **Chain Brake**  
Brek Rantai | 链条刹车

 **Auto Decompression**  
Penyahmampatan Automatik | 自动减压

 **Depth Adjustment**  
Pelarasan Kedalaman | 深度调整

 **Primer Pump**  
Pam Utama | 按压吸油

 **Rapid Start**  
Penghidupan Cepat | 快速启动

JV101DWAE / WYE / Z	93	RP0900	205	UH201DWAX / Z	95	M0400G	231
JV102DZ	94	RP1801	206	UH353DWA	95	M0600G	225
JV103DSMJ / WAJ / Z	93	RP2301FC	205	UH7580X	217	M0801G	226
<b>K</b>		RT0700C / X2	205	UM600DWA / Z	95	M0900G	227
KP0800X	203	<b>S</b>		UR100DSME / Z	95	M0910G	227
KP0810	203	SA5040C	186	UR201CZ 	38	M1100G	232
<b>L</b>		SC103DZJ 	92	UT1305	156	M1901G	232
LB1200F	202	SD100DWAJ / Z	93	UT2204	156	M1902G	232
LC1230	171	SG1251J	169	<b>V</b>		M2300G	230
LD030P	209	SJ401	202	VC1310LX1	139	M2400G	231
LD050P	210	SK104Z	209	VC2211M	138	M2401G	232
LD080P / PI	210	SK105DZ	96	VC2510L	139	M3600G	232
LF1000	197	SK105GDZ	96	VC3210L	139	M3601G	232
LH1201FL	196	SK106DZ	96	VC3211M	138	M3700G	233
LS0714	196	SK106GDZ	96	<b>W</b>		M3701G	233
LS1018L	195	SK209GDZ	96	WR100DWA / Z	90	M4000G	233
LS1019L	195	SK312GDZ	96			M4001G	233
LS1040	195	SP6000J	199			M4100G	231
LS1219L	195	ST113DWAJ / Z	94			M4301G	231
LS1440	196	<b>T</b>				M4302G	230
LW1400	173	TD001GD201 / Z 	27			M4501G	231
LW1401	173	TD0100	154			M5801G	230
<b>M</b>		TD0101F	154			M6001G	225
ML103	118	TD020DSW	99			M6200G	225
ML104 	117	TD022DSE	99			M6501G	225
ML105	117	TD090DWE	97			M6600XG	225
ML106	117	TD091DWE	98			M8100G	226
MLT100	197	TD110DSME / WAE / WYE / Z	89			M8103G	226
MP100DZ	95	TD111DSME / WAE / WYE / Z	88			M8600G	227
<b>N</b>		TL064DSME / WAE / Z	91			M8700G	226
N1900B	203	TL065DSME / WAE / Z	91			M8701X3G	226
N5900B	199	TM30DWAE / WAEX1 / Z	92			M9000G	229
<b>P</b>		TM3000C	190			M9001G	229
PC5000C	191	TM3010CX6	190			M9002G	228
PC5001C	191	TW001GM201 	27			M9200G	230
PC5010C	191	TW0200	157			M9201G	230
PJ7000	204	TW0350	157			M9202G	229
PK5001C	186	TW060DZ	90			M9204G	229
PLM4620N2	221	TW100DWE	98			M9400G	229
PLM5120	221	TW140DZ	89			M9503G	228
PLM5120N2	221	TW141DSME / WAE / Z	89			M9504G	228
PM7650H	219	TW160DZ	89			M9506G	227
PO5000C	188	TW161DSME / WAE / Z	89			M9508G	228
PO6000C	188	TW1000	156			M9509G	227
PT354DZ	94	<b>U</b>				M9511G	228
PTR2500	218	UB1103	210			M9512G	227
PV7000C	188	UC3541A	214			M9513G	227
PW5001C	191	UC3551A	213			M9800G	233
<b>R</b>		UC4041A	214				
RBC411U	211	UC4051A	213				

 **Stainless Tank**  
Tangki Tahan Karat | 不锈钢箱体

 **Revolving Hose**  
Hos Pusingan | 旋转软管

 **Static Free Hose**  
Hos Bebas Statik | 防静电胶管

 **Dust Collecting**  
Pengumpulan Habuk | 吸尘器连接

 **Built-in Job Light**  
Lampu Kerja Terbina | 内置工作灯

 **Wooden Carrying Case**  
Kotak Peralatan Kayu | 木制携带箱

 **Carrying Case**  
Kotak Peralatan | 携带箱

 **Sequential or Bump-fire**  
Sentakan Tunggal atau Berangkai | 连发模式

 **Auto Firing Stop**  
Nyalaan Terhenti Secara Auto | 自动停止发射



**XGT is a new system with its own tools, batteries, and chargers. A combination of innovative tool design and higher output batteries provide a genuine solution for high demand industrial users.**

XGT adalah sistem baru dengan alat, baterai dan pengeras yang unik. Kombinasi reka bentuk alat inovatif dengan baterai output tinggi memberikan penyelesaian bagi pengguna industri permintaan tinggi. 采用全新的XGT智能充电供电系统，具有独特的工具、电池和充电器。创新的工具设计和高输出的电池相结合，为高需求的工业用户提供了真正的解决方案。

## Tool ◀▶ Battery ◀▶ Battery Charger Digital communication

Alat Kuasa ◀▶ Bateri ◀▶ Pengecas Bateri | 工具 ◀▶ 电池 ◀▶ 充电器  
Komunikasi digital | 数码通讯



## Optimum power supply system and Optimum charging system

The XGT range of tools and batteries come with a built-in program, providing digital communication between the battery and tool. Allowing not only for the battery to talk with tool but also the tool to talk to the battery. Battery technology and motor engineering that work together for optimum performance.

Sistem Bekalan Kuasa dan Pengecasan Pintar XGT  
Bateri alat kuasa siri XGT mempunyai program terpasang untuk mewujudkan komunikasi dua hala antara bateri dan alat kuasa. Prestasi yang optimum dicapai dengan komunikasi antara teknologi bateri dan kejuruteraan motor yang berfungsi bersama  
XGT智能充电供电系统  
XGT系列产品工具的电池都有一个内置程序，实现电池与工具之间双向的通信，使电池和电机达到理想的性能。

### Optimum charging system

Auto maintenance system with two cooling fans for providing more optimum fast charging  
Sistem pengecasan pintar  
Pengecas mempunyai sistem penyelenggaraan automatik dan mempunyai dua kipas penyejuk  
智能充电系统  
充电器具有自动维护系统，并且拥有两个冷却风扇

### Built Tough

High durability specifications specially designed for 40Vmax Li-ion batteries  
Spesifikasi ketahanan tinggi direka khas untuk bateri Li-ion 40Vmax  
专为 40Vmax 锂电池设计的高耐用性结构

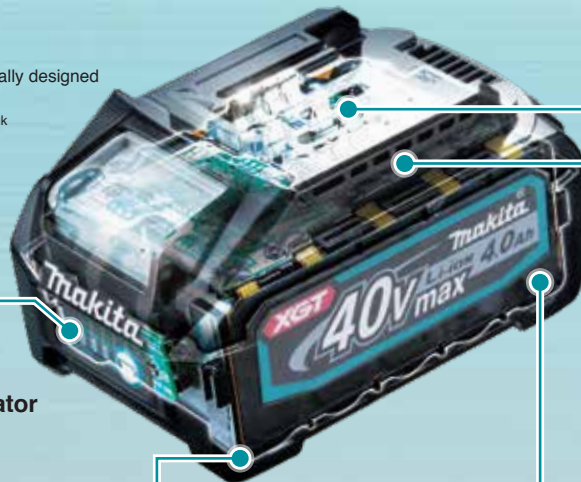

### 4-LED fuel gauge indicator

Penunjuk tahap bateri  
电池电量计指示灯



### Heavy duty outer casing and cell holder

Bekas lindung dan alas bateri yang kukuh 坚固的外壳和电池架  
Create a space to absorb impact  
Ruang tambahan untuk menyerap hentaman  
创造额外吸收冲击力的空间

### Shock absorption structure

Struktur penyerapan kejutan  
减震结构

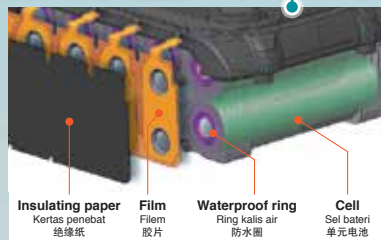

### Waterproof Triple-layer Structure

prevents cell failure due to water and dust  
Struktur kalis air tiga lapisan  
Mencegah kerosakan bateri akibat air dan habuk  
三层防水结构  
防止因水和灰尘引起的电池故障



### Terminal short-circuit prevention structure

The protection wall is provided between terminals against water and dust  
Struktur pencegahan litar pintas terminal  
Terdapat dinding pelindung kalis air dan tahan debu di antara terminal  
端子防短路结构  
端子之间设有防水防尘保护墙



### High Rigidity Battery Rails

Durable slide in battery rail that holds the battery and the tools firmly and securely to withstand high power products  
Slaid bateri berkekuatan tinggi  
Slaid tahan lama di rel bateri untuk pegangan bateri dan alat kuasa dengan kukuh, sesuai untuk kerja yang berbeban tinggi  
高强度电池滑轨  
耐用的滑动式滑轨，可牢固地连接电池和工具，更适合高负荷的工作



# OPTIMUM CHARGING SYSTEM

Sistem Pengisian Terbaik 智能充电系统



- It is necessary to cool down before start charging when the battery temperature is high  
Bateri yang baru diguna bersuhu tinggi, ia perlu didinginkan sebelum pengisian bermula  
刚使用完的电池处于高温状态, 要冷却后才能开始充电
- Built-in fan circulates air through the battery before start charging and during the charging process to cool the battery for faster charge time  
Kipas akan terus menyejukkan bateri semasa pengisian untuk mencapai pengisian cepat  
开始充电后, 风扇会持续冷却电池, 令充电时间更短

**FAST CHARGING**  
Pengisian Cepat 快速充电

**22 MINUTES**  
to fully charge a 3.0Ah slide Li-ion battery

\*Charge time may vary depending on battery model or conditions of use  
Masa pengisian mungkin berbeza bergantung kepada model bateri atau syarat penggunaan  
充电时间可能因电池型号或使用条件而异



**Makita**  
Optimum charging system  
Sistem Pengisian Terbaik 智能充电系统

Forced air cooling



Fast charging



Optimum charging system  
Sistem Pengisian Terbaik 智能充电系统

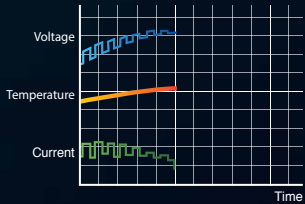

**Competitor**  
General charging method  
Kaedah Pengisian Umum 一般充电方式

Natural heat dissipation



Waiting time for charging



General charging method  
Kaedah Pengisian Umum 一般充电方式

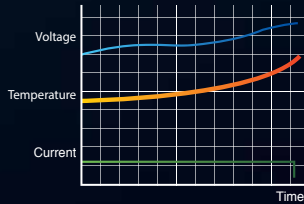

The Makita Rapid Optimum Charger communicates with the battery's built-in chip throughout the charging process to optimize battery life by actively controlling current, voltage and temperature

Makita Pengisian berkomunikasi dengan setiap sel unit dan mengawal arus, voltan dan suhu, membolehkan pengisian pantas dan memanjangkan hayat bateri  
Makita充电器与每个单元电池进行通信并控制电流, 电压和温度, 实现了快速充电, 且延长电池使用寿命

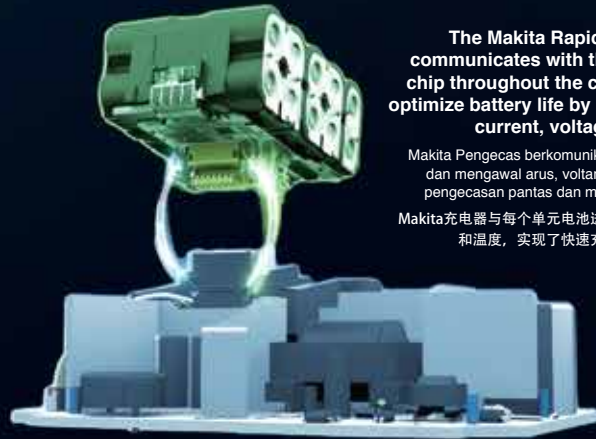

# BATTERY PROTECTION FUNCTION

Fungsi Perlindungan Bateri 电池保护功能

**Shock Absorbing**

Tahan getaran 坚固防震

**Heavy Duty Pack**

Pembungkusan tugas berat  
重型包装

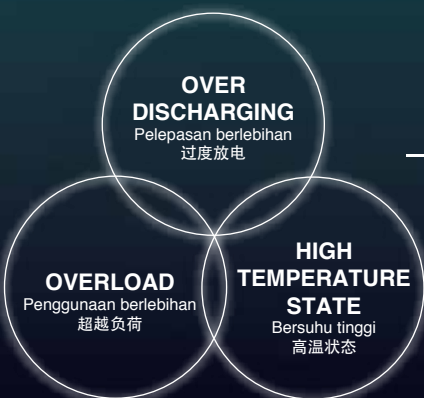

**Built-In-CPU**  
CPU dibina dalam 内置CPU

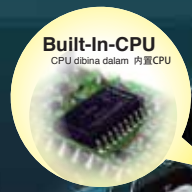

**Anytime Charge**

Caj pada bila-bila masa 随时充电

- No Memory Effect  
Tiada Kesan Memori 不受记忆影响
- No Discharging Required  
Tiada pelepasan diperlukan 不需要放电



Teknologi Ekstrim Litium-ion  
锂离子技术



Rechargeable Green Multi Line Laser  
Heated Jacket  
Heated Vest  
Fan  
Fan Vest  
Fan Jacket  
Cordless Inflator  
Vacuum Cleaner  
Cordless Cleaner  
Hedge Trimmer  
Job Site Speaker  
Job Site Radio  
Laser Level  
LED Flashlight  
Grass Shear  
Grass Trimmer  
Caulking Gun  
Driver Drill  
Hammer Driver Drill  
Impact Driver  
Angle Drill  
Cordless Impact Wrench  
Rotary Hammer  
Angle Impact Driver  
Multi Cutter  
Circular Saw  
Recipro Saw  
Cutter  
Pin Nailer  
Multi tool  
Drywall Saw  
Stapler  
Jig Saw  
Adapter for USB

12Vmax LITHIUM-ION  
12V Lithium-ion  
12V 锂离子

**CXT**  
Teknologi Ekstrim Kompak  
紧凑极限技术

## OPTIMUM CHARGING SYSTEM

Sistem Pengisian Terbaik 智能充电系统

**FAST CHARGING**  
Pengecasan Cepat 快速充电

**22 MINUTES**  
to fully charge a 1.5Ah slide Li-ion battery

\* Charge time may vary depending on battery model or conditions of use  
Masa pengecasan mungkin berbeza bergantung kepada model bateri atau syarat penggunaan  
充电时间可能因电池型号或使用条件而异



Cooling Fan  
Kipas Penyejuk 冷却风扇

## LI-ION BATTERY

Sistem bateri Li-ion 锂电池系统

### Multi-Contact Slide-type Terminal

Terminal slaid dengan pelbagai sambungan  
多触点滑动式终端

- Ensures stable contact with tool even under extreme vibration
- Allows tools to be equipped with an ergonomic handle design

- Memastikan sambungan yang stabil dengan alat walaupun di bawah getaran yang melampau
- Membolehkan alat dilengkapi dengan reka bentuk pemegang ergonomik
- 即使在极端的振动下也能确保与工具的稳定连接
- 允许工具配备符合人体工程学的手柄设计



### Battery fuel gauge

Penunjuk Tahap Bateri 电量显示

The power remaining in the battery can be indicated in 4 stages simply by pushing a button

Menekan butang untuk penunjuk tahap bateri  
只需按一下按钮，电池中剩余的电量就可以分四个阶段显示出来



### Charging status indicator

Penunjuk Status Mengecap 充电状态显示灯



shows the charging status of a battery being charged in 2 stages: less than 80% and 80% or more.



# BATTERY & CHARGER TIME REFERENCE, COMPATIBILITY CHART

Panduan tempoh pengecasan dan bateri 电池充电时间参考表, 兼容性图表

	<b>4.0Ah</b> BL4040 (191B26-6)	<b>2.5Ah</b> BL4025 (191B36-3)
	<b>Fast Charger DC40RA</b> Pengecas Pantas 快速充电器	<b>45 min.</b> <b>Fast Charging</b>

	<b>Fast Charger DC40RA</b> Pengecas Pantas 快速充电器 + <b>Adapter ADP10</b>	<b>Two Port Multi Rapid Charger DC18RD</b> (196934-4) Pengecas Pantas Dua Port 两端快速充电器	<b>Standard Charger DC18SD</b> (194534-4) Pengecas Standard 标准充电器
	<b>Rapid Charger DC18RC</b> (195586-8) Pengecas Pantas 快速充电器	<b>Dual Port Fast Charger DC18RE</b> (198446-3) Pengecas Pantas Dua Port 两端快速充电器	<b>Four Port Multi Charger DC18SF</b> (196427-1) Pengecas Biasa Empat Port 四端多功能充电器

	<b>6.0Ah</b> BL1860B (197422-4)	<b>40 min.</b>	<b>55 min.</b>	<b>Fast Charging</b>	<b>130 min.</b> 1 to 2 Batteries	<b>260 min.</b> 3 to 4 Batteries	<b>130 min.</b>
	<b>5.0Ah</b> BL1850B (197282-4)	<b>40 min.</b>	<b>45 min.</b>	<b>Fast Charging</b>	<b>110 min.</b> 1 to 2 Batteries	<b>220 min.</b> 3 to 4 Batteries	<b>110 min.</b>
	<b>4.0Ah</b> BL1840B (197265-4) (197267-0)	<b>29 min.</b>	<b>36 min.</b>	<b>Fast Charging</b>	<b>90 min.</b> 1 to 2 Batteries	<b>180 min.</b> 3 to 4 Batteries	<b>90 min.</b>
	<b>3.0Ah</b> BL1830B (197600-6)	<b>22 min.</b>	<b>22 min.</b>	<b>Fast Charging</b>	<b>60 min.</b> 1 to 2 Batteries	<b>120 min.</b> 3 to 4 Batteries	<b>60 min.</b>
	<b>2.0Ah</b> BL1820B (197256-5)	<b>24 min.</b>	<b>24 min.</b>	<b>Fast Charging</b>	<b>45 min.</b> 1 to 2 Batteries	<b>90 min.</b> 3 to 4 Batteries	<b>45 min.</b>
	<b>1.5Ah</b> BL1815N (196235-0) (196449-1)	<b>15 min.</b>	<b>15 min.</b>	<b>Fast Charging</b>	<b>30 min.</b> 1 to 2 Batteries	<b>60 min.</b> 3 to 4 Batteries	<b>30 min.</b>
	<b>1.3Ah</b> BL1815 (194513-2)	<b>15 min.</b>	<b>15 min.</b>	<b>Fast Charging</b>	<b>30 min.</b> 1 to 2 Batteries	<b>60 min.</b> 3 to 4 Batteries	<b>30 min.</b>

	<b>Speed Charger DC10SB</b> (197346-4) Pengecas Pantas 快速充电器	<b>Dual Port Fast Charger DC18RE</b> (198446-3) Pengecas Pantas Dua Port 两端快速充电器	<b>Standard Charger DC10WD</b> (197450-9) Pengecas Standard 标准充电器			<b>Standard Charger DC10WA</b> (194589-9) Pengecas Standard 标准充电器
	<b>4.0Ah</b> BL1041B (197406-2)	<b>60 min.</b> <b>Fast Charging</b>	<b>130 min.</b>	<b>1.3Ah</b> BL1013 (194550-8)	<b>1.0Ah</b> BL7010 (194355-4)	<b>50 min.</b> BL1013
<b>2.0Ah</b> BL1021B (197396-9)	<b>30 min.</b> <b>Fast Charging</b>	<b>70 min.</b>	<b>18V G-Battery</b>		<b>Standard Charger DC18WA</b> (195424-4) Pengecas Standard 标准充电器	
<b>1.5Ah</b> BL1016 (197393-5)	<b>22 min.</b> <b>Fast Charging</b>	<b>50 min.</b>	<b>1.5Ah</b> BL1815G (198186-3)	<b>70 min.</b>		

<b>14.4V Ni-MH</b> <b>3.1Ah</b> BH1433 (193354-3)	<b>12V Ni-MH</b> <b>3.1Ah</b> BH1233C (193930-3)	<b>9.6V Ni-MH</b> <b>3.1Ah</b> BH9033C (193591-9)	<b>Standard Charger DC18SD</b> (194534-4)	<b>Automotive Charger DC18SE</b> (194618-8) (194621-9)	<b>12V Ni-CD</b> <b>1.9Ah</b> 1222 (192597-4)	<b>9.6V Ni-CD</b>	<b>Standard Charger DC1414</b> (193865-8)			
<b>70 min.</b>	<b>70 min.</b>	<b>40 min.</b>	<b>40 min.</b>	<b>30 min.</b>	<b>1.3Ah</b> PA12 (193981-6)	<b>1.3Ah</b> 1220 (192681-5)	<b>1.3Ah</b> PA09 (193977-7)	<b>1.3Ah</b> 9120 (192638-6)	<b>1.3Ah</b> 9100 (192019-4)	<b>30 min.</b>
<b>14.4V Ni-MH</b> <b>2.8Ah</b> 1435 (193060-0)	<b>12V Ni-MH</b> <b>2.8Ah</b> 1235 (193059-5)	<b>9.6V Ni-MH</b> <b>2.8Ah</b> 9135 (193058-7)	<b>Standard Charger DC1414</b> (193865-8)	<b>70 min.</b>	<b>9.6V Ni-CD</b> <b>1.3Ah</b> 9000 (191681-2)	<b>7.2V Ni-CD</b> <b>1.3Ah</b> 7000 (191679-9)	<b>Standard Charger DC1414</b> (193865-8)			
<b>30 min.</b>	<b>30 min.</b>	<b>30 min.</b>	<b>30 min.</b>							

# BATTERY INFORMATION

Maklumat Bateri 关于电池的资讯

## How to Keep Your Batteries at Their Best

Cara menggunakan prestasi bateri yang terbaik 如何使用才能发挥电池的最佳效能

### Note the precautions below for keeping your batteries (Ni-Cd, Ni-MH, Li-ion) at their best to obtain maximum potential cycle life of batteries.

Perhatikan langkah penjagaan bateri berikut untuk memastikan bateri anda (Ni-Cd, Ni-MH, Li-ion) berada pada tahap terbaik untuk jangka hayat bateri berpotensi maksimum. 关于电池（镍镉、镍氢、锂电池）的最佳使用方法请参照下面的注意项目。电池将可得到最大的使用寿命。

#### 1. No over-discharge

Stop using a tool and charge the battery when the tool power goes down or its motor speed slows down. Do not use a cordless tool when its power goes down. Otherwise, it will cause an imbalance of battery cells and reduction of battery cycle life.

Elakkan pelepasan berlebihan. Jika alat kuasa anda daya lemah (pengurangan kelajuan putaran motor) semasa penggunaan, berhenti menggunakannya dengan segera dan mengecas bateri (bateri dapat diisi semasa suhu turun ke suhu bilik). Dilarang terus menggunakan alat kuasa apabila kekuatannya semakin lemah kerana ketidakseimbangan sel bateri akan mengurangkan jangka hayat bateri.

避免过度放电在使用工具中如果感觉到力道减弱(马达的回转速降低)时,须马上停止使用且稍后(电池温度降至室温即可充电)进行充电。严禁工具的力道减弱时还继续的使用。会因为元件容量的不均而导致电池寿命的短缺。

#### 2. No quick discharge

Avoid overloading during tool operation that causes quick discharge.

Elakkan beban berlebihan semasa operasi alat kuasa yang akan menyebabkan pelepasan cepat.

避免急速放电使用时请注意避免有过负载现象发生。

#### 3. No over-charge

Recharging a fully charged battery is called "Over-charge". This will cause reduction of battery cycle life.

Elakkan pengecasan berlebihan. Mengecas semula bateri yang dicas penuh disebut "Over-charge". Ini akan mengurangkan jangka hayat bateri.

避免过度充电。充电后满电状态又再次作充电动作。这称为(过充电)。是导致电池寿命降低的原因。

### If a fully charged battery is about to be charged, Makita automatic maintenance function will stop recharging immediately to prevent battery deterioration.

Sekiranya bateri yang penuh dicas semula, fungsi penyelenggaraan automatik akan diaktifkan untuk menghentikan tindakan pengecasan untuk mengelakkan kerosakan bateri. 牧田滑动式电池对于充满电后又再次作充电动时,自动保养机能会启动,将充电动作停止,防止电池的劣化产生。

#### 4. Charge your batteries at an ambient temperature from 10°C to 40°C

Do not charge batteries cold from storage at a low ambient temperature below 10°C, or they are damaged. Also batteries are damaged at a high ambient temperature above 40°C. as the deterioration of battery cell materials are hastened by such a high temperature. Therefore, optimum air temperature for charging of batteries is from 10°C to 40°C. When you recharge a battery hot from operation of tool, do not leave it in the tool, but set it on the Makita charger for slide style batteries that will cool down the hot battery fast and efficiently with its forced air cooling system before recharging. This unique system will surely protect batteries from deterioration from heat.

Mengecas bateri yang disimpan pada suhu persekitaran antara 10 °C hingga 40 °C. Pengecasan bateri yang disimpan pada suhu persekitaran rendah (di bawah 10 °C) akan menyebabkan kerosakan bateri. Pengecasan bateri yang disimpan pada suhu persekitaran tinggi (melebihi 40 °C), kemerosotan bahan dalaman bateri akan dipercepat dan menyebabkan kerosakan bateri. Keluarkan bateri yang panas dari alat kuasa selepas penggunaan dan letakkan bateri pada pengecas. Pengecas Makita akan menyejukkan bateri panas dengan cepat dan cekap dengan sistem penyejukan sebelum mengecas semula. Sistem yang unik ini melindungi bateri daripada kerosakan akibat panas.

在10°C以下的低温环境中保管的电池如果进行充电,将对电池的本身造成伤害。另外,在40°C以上的高温环境下,会加速电池内部材料的劣化,也会对电池的本身造成伤害。在10°C~40°C的温度内充电是最合适的。刚使用完且还有些发热的状态的电池,不要插在电动工具上。需移至充电器。充电器的冷却装置会很有效率的将电池散热后再进行充电,如此,可以防止发热导致电池劣化的情形发生。

#### 5. Keep your batteries away from moisture

High humidity and extreme temperature swings cause dew drop, and it will cause rust and short-circuit.

Elakkan bateri dari wap air. Kelembapan tinggi dan perubahan suhu yang melampau akan menyebabkan karat dan litar pintas.

不要触碰水气。生锈是短路的原因,高温,极端的温度差会导致结露现象产生。

#### 6. Do not exert any significant impact on batteries

String impact on battery will cause internal wire breakage or cracks on battery housing.

Elakkan hentakan ketara yang akan menyebabkan kerosakan wayar dalaman atau keretakan pada penutup bateri.

不要强烈撞击,外壳的破损,是内部断线的原因。

Charge the battery when the motor speed slows down!  
Mengecas bateri apabila kelajuan motor alat kuasa menjadi perlahan  
转速降低时,立即停止使用,准备充电!



## Battery Care & Storage

Penjagaan & simpanan bateri 电池的保管方法

### Store batteries at an ambient temperature below 35°C. Avoid storing batteries at a high air temperature and humidity

Simpan bateri pada suhu persekitaran di bawah 35°C, elakkan menyimpan bateri pada suhu dan kelembapan udara yang tinggi 将电池存放在低于35°C的环境温度下,避免将电池存放在空气温度和湿度高的地方

#### Storage in fully charged condition

Jenis bateri yang mesti disimpan dalam keadaan terisi penuh  
须在充满电状态下保管的电池种类



Li-ion Battery  
Bateri Li-ion 锂电池



Ni-MH Battery  
Bateri Ni-MH 镍氢电池

#### Storage in fully discharged condition

Jenis bateri yang mesti disimpan dalam keadaan habis  
须在放电状态下保管的电池种类



Ni-CD Battery  
Bateri Ni-CD 镍镉电池

※ Ni-MH batteries have to be charged once a year due to its self-discharging nature. Bateri Ni-MH harus dicas setahun sekali kerana ciri pelepasan diri. 由于镍氢电池自放电特性,建议每年充电一次。

※ Ni-CD batteries have to be fully discharged before storage. After storage for sometimes, ensure Ni-CD batteries are fully charged before use. Bateri Ni-CD mesti dilepaskan sepenuhnya sebelum disimpan. Setelah disimpan untuk jangka waktu tertentu, pastikan bateri Ni-CD dicas penuh sebelum digunakan. 镍镉电池必须在存放前完全放电。存放一段时间后,请确保镍镉电池在使用前已充满电。

# CORDLESS ADVANTAGE

Tanpa Kord 充电式优势



## Easy to Use

Mudah digunakan 方便使用

### Start-up

Alat enjin 引擎工具

### Engine tools

Peralatan enjin 引擎工具



**Engine tools need time and tips to start-up**  
Peralatan enjin memerlukan masa untuk dihidupkan  
引擎工具需要时间和技巧来启动

### Cordless tools

Peralatan tanpa kord 充电式工具



**Cordless tools start just after inserting battery and switching on**  
Peralatan tanpa kord mudah dihidupkan dengan pemasangan bateri sahaja  
安装电池后并开启充电式工具便可开始工作

### Constant speed control

Kelajuan tetap 电子恒速控制

### Engine tools

Peralatan enjin 引擎工具



**Engine tools are hard to keep the constant rotation speed under load**  
Peralatan enjin sukar untuk mengekalkan kelajuan putaran berterusan  
引擎工具很难在负载下保持恒定的转速

### Cordless tools

Peralatan tanpa kord 充电式工具



**Cordless tools keep rotation speed under load with "Constant speed control" function**  
Peralatan tanpa kord berfungsi "kawalan kelajuan putaran berterusan"  
充电式工具保持旋转"恒定负载下的速度"控制功能

### Low noise (Noise level comparison)

Bunyi rendah 低噪声

### Engine tools

Peralatan enjin 引擎工具



### Cordless tools

Peralatan tanpa kord 充电式工具



## Clean & Easy Maintenance

Bersih dan mudah dijaga 清洁和容易保养



### Zero emission

Tanpa pelepasan asap 无排气

### Engine tools

Peralatan enjin 引擎工具



### Cordless tools

Peralatan tanpa kord 充电式工具



**Cordless tools don't generate any exhaust gas**  
Peralatan tanpa kord tidak mengeluarkan gas ekzos  
充电式工具不会产生废气

### Cost and time reduction

Kurangkan kos dan masa 减少成本和時間

### Engine tools

Peralatan enjin 引擎工具



**It takes time to prepare mixed fuel for engine**  
Mengambil masa untuk menyediakan bahan api campuran untuk Enjin 需时为发动机准备混合燃料

### Cordless tools

Peralatan tanpa kord 充电式工具



**Just insert battery and ready to use**  
Pasangkan bateri dan sedia untuk digunakan  
只需安装电池即可使用

### Easy maintenance

Penyelenggaraan mudah 易于维护

### Engine tools

Peralatan enjin 引擎工具

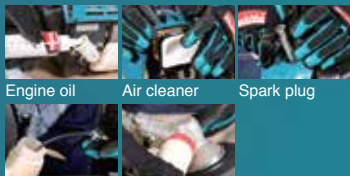

Engine oil Air cleaner Spark plug  
Fuel plug Grease up

### Cordless tools

Peralatan tanpa kord 充电式工具



**Cordless tools are maintenance - Free unlike engine tools**  
Peralatan tanpa kord bebas dari penyelenggaraan  
充电式工具免维护

### Long term storage

Penyimpanan jangka panjang 长期存放

### Engine tools

Peralatan enjin 引擎工具



**If you store the tool for a long period, when the fuel remained in the tank It may be a cause of trouble or defect**  
Peralatan enjin mungkin akan rosak sekiranya disimpan lama dengan bahan api dalam tangki  
燃油长时间留在油箱可能会造成工具故障

### Cordless tools

Peralatan tanpa kord 充电式工具



**Even if you store the tools for a long period, Just insert battery and ready to use**  
Walaupun menyimpan peralatan dalam jangka masa yang panjang, ia sedia digunakan dengan pemasangan bateri  
充电式工具即使长时间存放, 只需安装电池即可使用

## Purpose-built Brushless Motors

Motor tanpa berus 无碳刷马达

Makita-built Brushless Motor eliminates carbon brushes, enabling the motor to run cooler and more efficiently for longer life. The electronically controlled Brushless Motor efficiently uses energy to match torque and RPM to the changing demands of the application

Motor tanpa berus yang dibuat oleh Makita menghapuskan berus karbon, membolehkan motor berjalan lebih sejuk, lebih cekap dan lebih tahan lama. Motor tanpa berus yang dikawal secara elektronik dengan cekap menggunakan tenaga untuk menyesuaikan tork dan RPM kepada perubahan permintaan aplikasi. Makita制造的无碳刷马达消除了碳刷, 使马达更冷却的运作, 更有效, 更长使用寿命。电子控制的无碳刷马达有效地利用能量将扭力及RPM以配合不断变化的需求

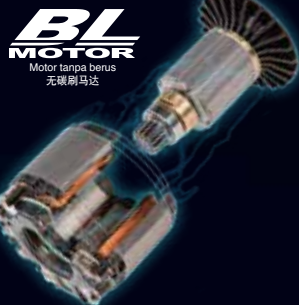

## Enhanced dust and drip-resistant performance of the tools

Prestasi tahan debu dan tahan titisan air  
提高工具的防尘与防水滴性能, 令工具更耐用

**XPT**  
EXTREME PROTECTION TECHNOLOGY  
Teknologi Perlindungan Ekstrem  
防尘防水滴技术



Image is for advertising effects only  
Image hanya untuk kesan iklan 图片仅为广告特效

# AWS

**Auto - start Wireless System**  
Sistem permulaan wayarles automatik  
无线自动启动系统



## Connects to Compatible Vacuum Cleaners with Bluetooth

Sambungan tanpa wayar dengan pembersih vakum yang serasi dengan Bluetooth 通过蓝牙连接到兼容的吸尘器



### WUT01 wireless unit

Enables wireless connection of Makita AWS™ capable tools with AWS™ Vacuum Cleaners



Part No.199393-1

Untuk sambungan tanpa wayar alat kuasa AWS™ Makita dengan pembersih vakum AWS™

Makita AWS™ 工具与AWS™ 吸尘器无线连接

### WUT02 wireless unit adapter

Enables wireless connection of Makita AWS™ capable tools with most AC vacuum cleaner with auto start/ stop functions



Part No.199809-6

Sambungan tanpa wayar alat kuasa AWS™ Makita dengan pembersih vakum AC yang berfungsi permulaan/ berhenti automatik

无线连接具有Makita AWS™ 功能的电动工具与具有自动启动/停止功能的AC吸尘器

DGA701 | DGA901



DHR400



DHR282



DGA414 | DGA418



DSP601



DVC864L



DVC154L



DVC265



DLS111 | DLS211



DSL800



**Switch on the tool and the vacuum cleaner will start automatically**

Hidupkan alat kuasa dan pembersih vakum akan bermula secara automatik  
启动电动工具，吸尘器将自动启动

# AVT

ANTI VIBRATION TECHNOLOGY

Teknologi Anti Getaran  
防振技术



- Vibration absorbing housing
- Active dynamic vibration absorber
- Damper spring

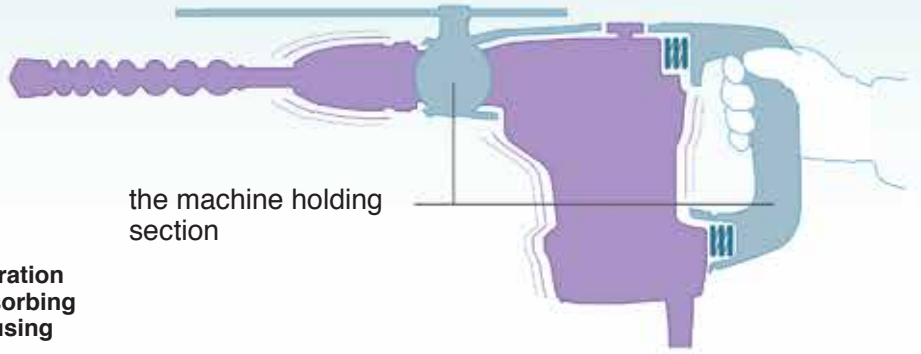

the machine holding section

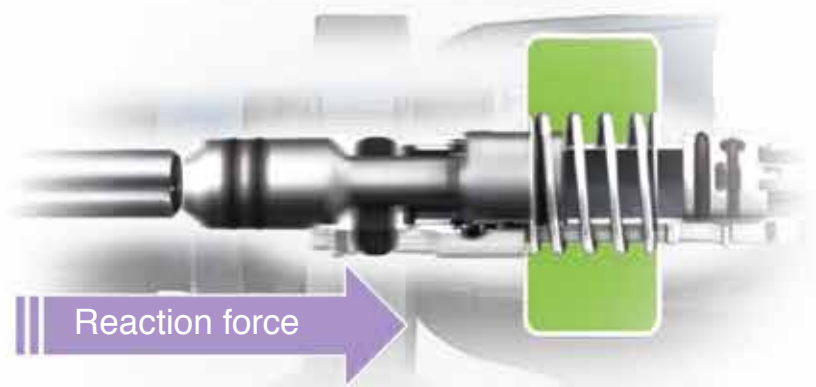
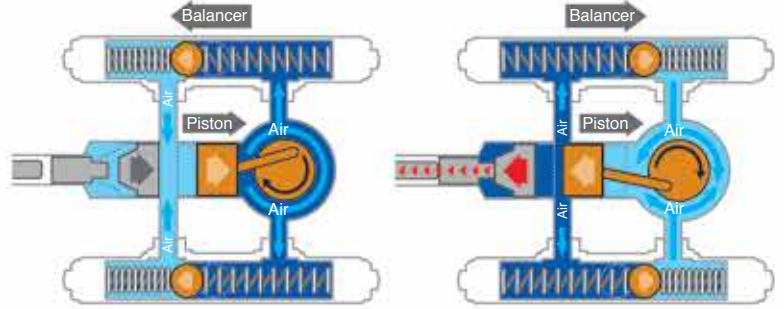

## SOFT NO LOAD

Getaran rendah tanpa beban  
无负载时低振动

During no-load



## Suppression of motor speed

Penindasan kelajuan motor 电机转速的抑制

- reduces vibration of tool body when idling, accordingly decreases the amount of vibration to operator's hands during a day's operation  
mengurangkan getaran badan alat ketika melahu, dengan itu mengurangkan jumlah getaran ke tangan pengendali semasa operasi sehari 减少空转时工具主体的振动, 从而减少一天操作中操作者手部的振动量
- minimizes deflection of bit tip from aiming point when starting chipping  
meminimumkan pesongan bit tip dari titik sasaran apabila memulakan kerepotan 开始切屑时, 将刀尖从瞄准点的偏移减至最小

During no-load

Under load

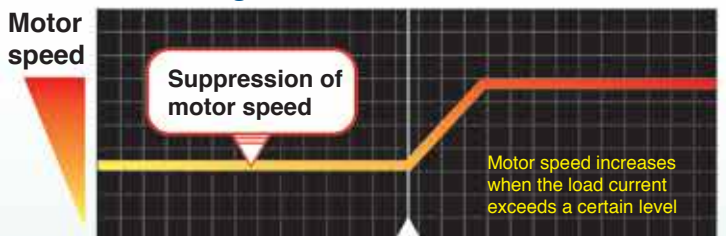

when starting chipping

Motor speed increases when the load current exceeds a certain level

## Equipped with automatic speed control

Dilengkapi dengan kawalan laju automatik 设置自动速度控制功能



**Automatically changes the cutting speed according to load conditions for an optimum operation**  
Fungsi pertukaran kelajuan automatik 自动变速功能

- On light duty: high-speed rotation mode
- On heavy duty: high torque mode
- Pada tugas ringan: mod putaran berkelajuan tinggi
- Pada tugas berat: mod torq tinggi
- 轻载: 高速旋转模式
- 重载: 高扭矩模式

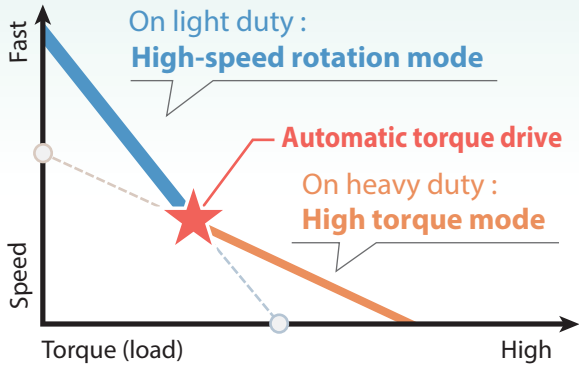

## Smart function to minimize the danger of kick-back

Fungsi pintar untuk mengurangkan risiko kick-back 智慧型功能可减少反冲之危



**Shuts down the tool to protect the user, if the rotation speed suddenly slows down**

Jika kelajuan putaran tiba-tiba dikurangkan, alat akan dimatikan secara automatik untuk melindungi pengguna

若旋转速度突然降低, 工具将自动关闭以保护使用者

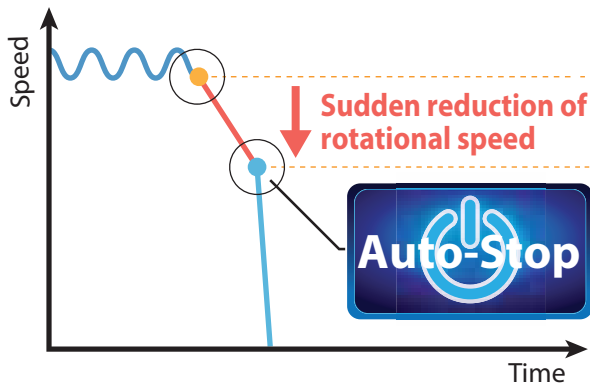

Electric Brake System  
Sistem Brek Elektrik 电子自动刹车系统

### Electric brake

Brek elektrik 电子自动刹车

**Electric brake is activated after the tool is switched off**

Brek elektrik diaktifkan selepas alat dimatikan

电子自动刹车在工具关闭后被启动

### Large switch lever

Tuas suis yang besar 大开关杆

**with lock-off function (without lock-on function)**

Lock-off function prevents the switch lever from being accidentally pulled

dengan fungsi mengunci

menghalang tuas suis daripada ditarik secara tidak sengaja

锁定功能可防止开关杆被意外拉动

### Anti-restart function

Fungsi anti-restart 防止意外重启功能

**The motor does not start up if battery is inserted when the switch slid to "on".**

Selepas memuatkan bateri, motor tidak bermula jika suis ditetapkan ke kedudukan "ON"

装入电池后, 若开关设于「开启」位置时, 马达不会启动

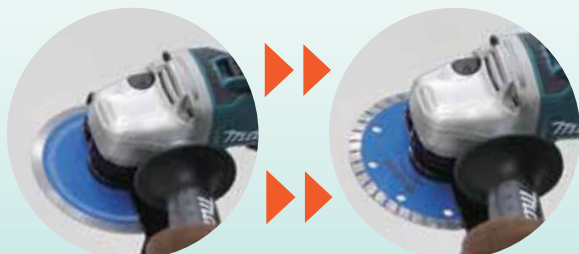

Electric brake is activated after the tool is switched off  
Brek elektrik diaktifkan selepas alat dimatikan  
电子自动刹车在工具关闭后被启动







## TO SUPPRESS VIBRATION TO OPERATOR

Menahan Getaran 在操作时能抑止震动

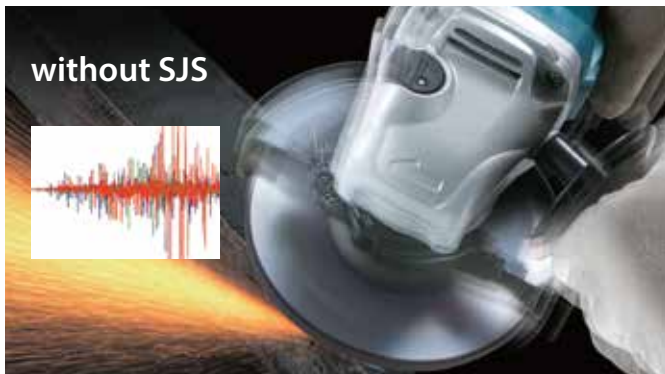

## Structure of Super Joint System II

Struktur SJS generasi kedua 第二代 SJS 的结构

Leaf spring absorbs vibration and relieves shock during operation.

Leaf spring menyerap getaran dan mengurangkan kesan hentaman semasa operasi 在运行过程中，弹簧片吸收振动并减轻冲击



## Absorption mechanism of vibration

Mekanisme penyerapan getaran 振动的吸收机能

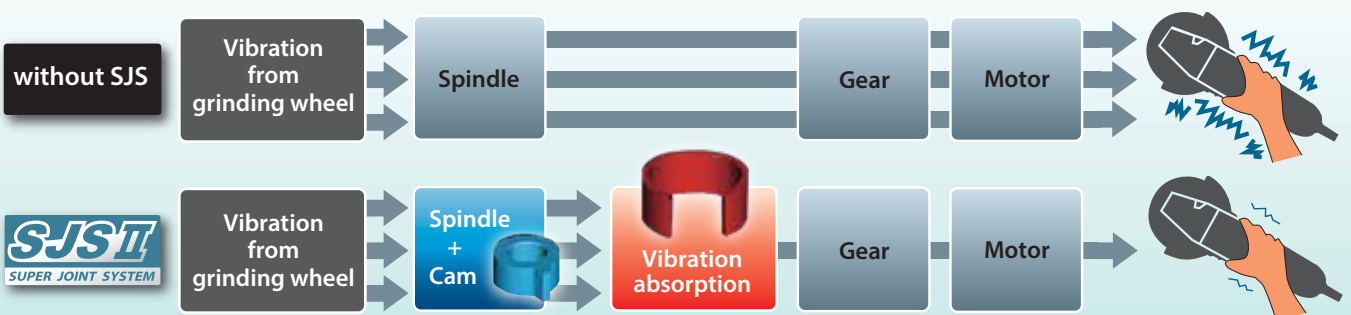

# Automatic Self-cleaning Filtration System achieved by two filter units

Sistem Penapis Penyucian Automatik 自动清洗过滤系统

**Constantly high suction power throughout operation because dust is removed from Prefilters every 10 seconds during operation**

Kuasa penyedut yang berterusan sepanjang operasi kerana habuk dikeluarkan dari penapis setiap 10 saat semasa operasi

在整个运行过程中吸力保持在较高的水平，因为在运行过程中，每10秒就会从过滤器中除去灰尘



# Automatic self-cleaning filter (VC1310L, VC2510L, VC3210L)

Sistem Penapis Penyucian Automatik 自动清洗过滤系统

**obtained by Triple filter structure composed of: Powder filter + Damper + Prefilter**

Kuasa penyedutan yang berterusan sepanjang operasi kerana habuk dikeluarkan dari Prefilters setiap 10 saat semasa operasi

由三重过滤器结构得到：粉末过滤器+阻尼器+预过滤器



When the power is switched on, Prefilter collapses into itself, to compress Damper, and fits closely over Damper and Powder filter.

Apabila kuasa dihidupkan, Prefilter runtuh ke dalamnya untuk memampatkan Damper, dan sesuai dengan penapis Damper dan Serbuk.  
当接通电源时，Prefilter会自行折叠以压缩阻尼器，并紧密贴合阻尼器和粉末过滤器。

When the power is switched off, Damper expands back to its original size and shakes off dust from Prefilter automatically with its expanding power.

Apabila kuasa dimatikan, Damper mengembang kembali ke saiz asalnya dan menggelakkan habuk dari Prefilter secara automatik dengan kuasa yang berkembang.  
当电源关闭时，阻尼器膨胀回到其原始尺寸，并通过扩展的功率自动将Prefilter的灰尘抖落。



# DEEP CUTTING

Pemotongan dalam 深层切割

# DXT

Deep and Exact Cutting Technology

Teknologi Pemotongan Ketepatan Dalam  
深层精准切割技术

3-Stage reduction gear unit and Movable rear blade guard provide larger capacities of cutting Crown molding and Baseboard (Skirt board)

Peranti gear pengurangan tiga peringkat dan tutup belakang bilah gergaji boleh alih untuk pemotongan mudah diagonal garisan siling dan garis sudut (panel dinding) 三级减速齿轮装置及活动的后锯片护罩, 方便斜切天花板线和墙角线(护壁板)

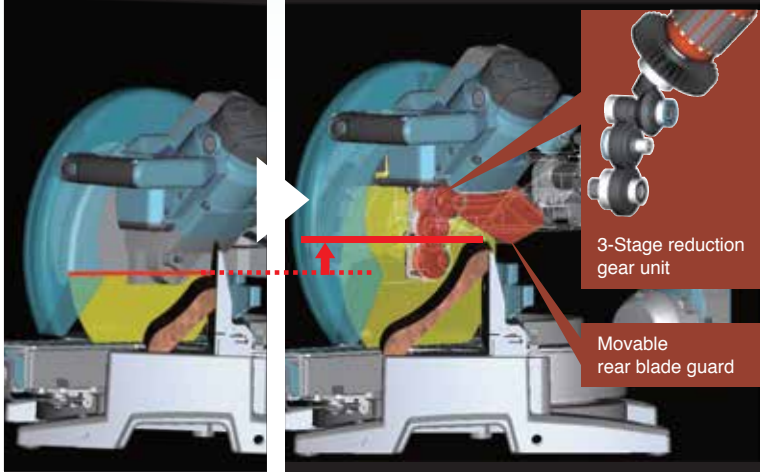

Capable of diagonal cutting up to **203mm (8")** crown molding

Capable of vertical cutting up to **165mm (6-1/2")** baseboard (skirt board)



# EXACT CUTTING

Pemotongan ketepatan 精准切割

## Double sliding mechanism

Teknologi pemotongan ketepatan dalam 双重滑动结构

Makita advantages obtained by using 4 short steel poles instead of 2 long poles are;

- Vibration-free, precise and exact cutting
- Compact tool design for jobsite portability

Gantikan 4 paip keluli panjang dengan 4 paip keluli pendek, supaya produk Makita mempunyai kelebihan berikut

- Bebas getaran, pemotongan tepat
- Reka bentuk alat padat untuk kemudahan medan

以4支短钢管取代2支长钢管, 令牧田产品有以下优势之处  
• 无振动, 精确切割 • 紧凑的工具设计可实现现场便携性

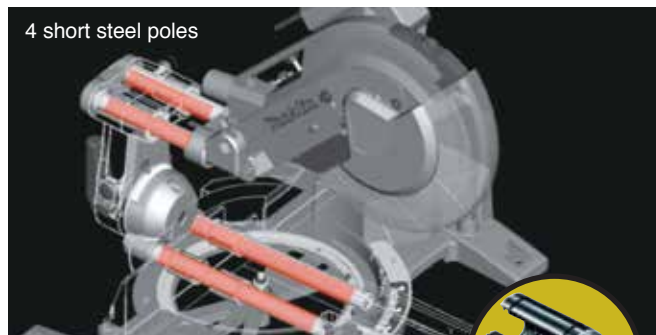

4 short steel poles

6 linear ball bearings are used to support the 4 poles for smooth and precise sliding cut.



## Double sliding guide fence

Teknologi pemotongan ketepatan dalam 双重滑动引导栅

The upper and the lower sections slide independently for added convenience; each upper fence slides outwards for bevel cut, and each lower fence slide inwards to securely hold small workpiece for precise and exact cutting

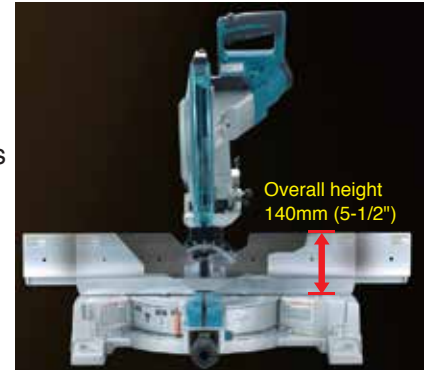

Overall height 140mm (5-1/2")

Bahagian atas dan bawah meluncur secara berasingan untuk kemudahan tambahan, grid panduan atas boleh meluncur ke luar pada sudut serong untuk dipotong, dan grid panduan bawah dapat meluncur ke dalam untuk memegang bahan-bahan kecil untuk memotong tepat

上下部分独立滑动以增加便利; 上部引导栅能向外滑动斜角切割, 而下部引导栅能向内滑动以牢牢地固定小材料, 以进行精确的切割



## Quick and accurate miter angle lock

Kunci sudut miter yang cepat dan tepat  
快速准确的斜接角度锁定

- Miter angle can be locked/unlocked simply by turning the knob 90 degrees.
- With positive stops at 0, 15, 22.5, 31.6, 45 degrees



DLS111



DLS211



DLS600



LS1019L



LS1219L

# MAKPAC POWER SOURCE KIT

Set Bateri MAKPAC | MAKPAC锂电池套装

**XGT 40V Li-ion max**



1x Fast Charger DC40RA (191E08-6)  
Pengecas Pantas 快速充电器

2x 4.0Ah Battery BL4040 (191B26-6)  
Bateri 锂电池

**BASIC 40Vmax 4.0Ah**  
(191J70-1)

**XGT 40V Li-ion max**



1x Fast Charger DC40RA (191E08-6)  
Pengecas Pantas 快速充电器

2x 2.5Ah Battery BL4025 (191B36-3)  
Bateri 锂电池

**POWER 40Vmax 2.5Ah**  
MKP1G001 (191J86-6)

**XGT 40V Li-ion max**



1x Fast Charger DC40RA (191E08-6)  
Pengecas Pantas 快速充电器

2x 4.0Ah Battery BL4040 (191B26-6)  
Bateri 锂电池

**ADVANCED 40Vmax 4.0Ah**  
MKP1G002 (191K02-4)

**18V LITHIUM-ION**  
18V Litium-ion  
18V 锂离子



1x Rapid Charger DC18RC (195586-8)  
Pengecas Pantas 快速充电器

1x 3.0Ah Battery BL1830B (197600-6)  
Bateri 锂电池

**BASIC 18V 3.0Ah**  
MKP1RF181 (197973-7)

**18V LITHIUM-ION**  
18V Litium-ion  
18V 锂离子



1x Rapid Charger DC18RC (195586-8)  
Pengecas Pantas 快速充电器

2x 3.0Ah Battery BL1830B (197600-6)  
Bateri 锂电池

**POWER 18V 3.0Ah**  
MKP1RF182 (197974-5)

**18V LITHIUM-ION**  
18V Litium-ion  
18V 锂离子



1x Rapid Charger DC18RC (195586-8)  
Pengecas Pantas 快速充电器

2x 4.0Ah Battery BL1840B (197265-4)  
Bateri 锂电池

**POWER 18V 4.0Ah**  
MKP1RM182 (191L71-1)

**18V LITHIUM-ION**  
18V Litium-ion  
18V 锂离子



1x Rapid Charger DC18RC (195586-8)  
Pengecas Pantas 快速充电器

1x 5.0Ah Battery BL1850B (197282-4)  
Bateri 锂电池

**BASIC 18V 5.0Ah**  
MKP1RT181 (197801-6)

**18V LITHIUM-ION**  
18V Litium-ion  
18V 锂离子



1x Rapid Charger DC18RC (195586-8)  
Pengecas Pantas 快速充电器

2x 5.0Ah Battery BL1850B (197282-4)  
Bateri 锂电池

**POWER 18V 5.0Ah**  
MKP1RT182 (197803-2)

**18V LITHIUM-ION**  
18V Litium-ion  
18V 锂离子



1x Two Port Multi Rapid Charger DC18RD (196934-4)  
Pengecas Pantas Dua Port 两端快速充电器

2x 5.0Ah Battery BL1850B (197282-4)  
Bateri 锂电池

**ADVANCED 18V 5.0Ah**  
MKP3PT182 (198182-1)

**18V LITHIUM-ION**  
18V Litium-ion  
18V 锂离子



1x Two Port Multi Rapid Charger DC18RD (196934-4)  
Pengecas Pantas Dua Port 两端快速充电器

4x 5.0Ah Battery BL1850B (197282-4)  
Bateri 锂电池

**ULTIMATE 18V 5.0Ah**  
MKP3PT184 (197627-6)

**18V LITHIUM-ION**  
18V Litium-ion  
18V 锂离子



1x Rapid Charger DC18RC (195586-8)  
Pengecas Pantas 快速充电器

2x 6.0Ah Battery BL1860B (197422-4)  
Bateri 锂电池

**ADVANCED 18V 6.0Ah**  
MKP1RG182 (198119-8)

**18V LITHIUM-ION**  
18V Litium-ion  
18V 锂离子



1x Two Port Multi Rapid Charger DC18RD (196934-4)  
Pengecas Pantas Dua Port 两端快速充电器

4x 6.0Ah Battery BL1860B (197422-4)  
Bateri 锂电池

**ULTIMATE 18V 6.0Ah**  
MKP3PG184 (198095-6)

**12Vmax LITHIUM-ION**  
12V Litium-ion  
12V 锂离子



1x Speed Charger DC10SB (197346-4)  
Pengecas Pantas 快速充电器

2x 1.5Ah Battery BL1016 (197393-5)  
Bateri 锂电池

**BASIC 12Vmax 1.5Ah**  
MKP1SY122 (197654-3)

**12Vmax LITHIUM-ION**  
12V Litium-ion  
12V 锂离子



1x Speed Charger DC10SB (197346-4)  
Pengecas Pantas 快速充电器

2x 2.0Ah Battery BL1021B (197396-9)  
Bateri 锂电池

**POWER 12Vmax 2.0Ah**  
MKP1SA122 (197664-0)

**12Vmax LITHIUM-ION**  
12V Litium-ion  
12V 锂离子



1x Speed Charger DC10SB (197346-4)  
Pengecas Pantas 快速充电器

2x 4.0Ah Battery BL1041B (197406-2)  
Bateri 锂电池

**ULTIMATE 12Vmax 4.0Ah**  
MKP1SM122 (197640-4)

# Portable Power Pack

Bekalan kuasa mudah alih 便携式电源

## PDC01



18V Lithium-ion X2  
18V 锂离子 X2



18V Lithium-ion  
18V 锂离子



Teknologi Ekstrem Litium-ion  
锂离子技术

# Comfortable For Long Hours Operation

Selesa untuk operasi masa panjang 舒适的长时间操作

**Battery cover**  
Protection from water and dust  
Penutup bateri untuk perlindungan daripada air dan habuk  
防水防尘电池盖

**Comfortable, adjustable backpack harness**  
Harness ransel yang selesa dan boleh laras 舒适可调节的背带

**Fuel gauge for each battery indicates the battery status by two green lights**  
Penunjuk tahap bateri  
menunjukkan status bateri dengan dua lampu hijau  
每个电池的电量计。通过两个绿色指示灯指示电池状态

**Main power switch With auto-off function**  
Suis kuasa utama dengan fungsi auto-off  
主电源开关具有自动关机功能

**Cord length 1.7m**  
Panjang kord 1.7m 长1.7m

**Lightweight 7kg with 4x 5.0Ah batteries**  
Reka bentuk ringan - hanya 7kg dengan bateri 4x 5.0Ah  
轻巧的设计, 配备4个5.0Ah电池仅重7公斤

(Without Battery)



**Continuous Usage Time (approx.)**  
Masa Penggunaan Berterusan 连续使用时间

**High Speed: 2 hours 50 minutes**  
**Low speed: 12 hours 10 minutes**



**Continuous Usage Time (approx.)**  
Masa Penggunaan Berterusan 连续使用时间

**Dial 6: 24 minutes**  
**Dial 1: 2 hours 48 minutes**



**Work Amount (approx.)**  
Jumlah Kerja 工作量

**60 holes**  
Concrete compressive strength  
Grade 40 φ18mm depth 140mm

### TWO VARIATIONS

(Without Battery) + 18Vx2 Adapter only Part No.191A67-6

(Without Battery) + 18V & 18Vx2 Adapter Part No.191A62-6

## Recommended products

Produk yang disyorkan 推荐产品



Cordless Chain Saw



Cordless Blower



Cordless Grass Trimmer



Cordless Hedge Trimmer



Cordless Angle Grinder



Cordless Rotary Hammer (except DHR282)

# Convenience for every OCCASION

Sesuai Untuk Pelbagai Kegunaan/ 适用于任何场合

Heat-resistant Temperature  
0 ~ 60°c  
Suhu tahan haba 0 ~ 60°c  
保冷度 0 ~ 60°c

Maintaining COOL Temperature  
Mengekalkan suhu sejuk  
冷藏专用

## MAKPAC Cool Box

Kotak Sejuk MAKPAC/ 层叠式冷藏箱

20mm thickness formed polystyrene, sealing strips are placed around the mating surface of lid and box

Dibuat dari ketebalan 20mm polistirena dan dipasang dengan jalur pendedap di sekeliling permukaan penutup dan kotak  
箱体壁厚为20mm, 盖子和箱子的连接处配备密封条



11L

500mL x 10 | 2L x 2

(Type 3)

Part No. 198254-2

- Dimensions  
Dimensi | 体积 (L x W x H)  
295 x 395 x 210mm (11-5/8" x 15-1/2" x 8-1/4")
- Net weight  
Berat bersih | 净重  
2.9kg (6.3lbs)



• Both type can be equipped with a shoulder strap

Kedua-dua jenis Makpac boleh dipasang dengan tali pemegang bahu  
两种型号皆可配备肩带



Come with Shoulder belt  
Dilengkapkan dengan tali pemegang bahu | 配备背负肩带



18L

500mL x 20 | 2L x 4

(Type 4)

Part No. 198253-4

- Dimensions  
Dimensi | 体积 (L x W x H)  
295 x 395 x 315mm (11-5/8" x 15-1/2" x 12-3/8")
- Net weight  
Berat bersih | 净重  
3.7kg (8.1lbs)



Type 1  
Part No. 821549-5

Type 2  
Part No. 821550-0

Type 3  
Part No. 821551-8

Type 4  
Part No. 821552-6

• MAKPAC Box  
Kotak Makpac  
工具连接箱



Part No. TR00000002  
• Able to stack on MAKPAC trolley for easy loading (option)

Boleh ditambah dan disambung atas troli Makpac untuk memudahkan kerja pengalihan kotak Makpac (pilihan)  
Makita工具箱可以添加并连接到拖运车, 以方便搬运(选择性)



**18V**  
Lithium-ion

**LXT**

Teknologi Ekstrim Lithium-ion  
锂离子技术

# CORDLESS COMBO KIT

Pakej kombo peralatan tanpa kord 充电式工具套装

**18V**  
LITHIUM-ION  
18V Lithium-ion | 18V 锂离子

**CORDLESS COMBO KIT**  
Pakej kombo peralatan tanpa kord 充电式工具套装

**DLX2248PT1**



**1** 1x DVC260Z

**Cordless Backpack Vacuum Cleaner**  
Pembersih Vakum Beg Galas Tanpa Kord  
充电式背负吸尘器

**2x 5.0Ah Battery (BL1850B)**  
Bateri 5.0Ah (BL1850B)  
5.0Ah 电池 (BL1850B)

**2** 1x DCL181F Cordless Cleaner  
Pembersih Vakum Tanpa Kord  
充电式便携吸尘器

**1x 5.0Ah Battery (BL1850B)**  
Bateri 5.0Ah (BL1850B)  
5.0Ah 电池 (BL1850B)

**3** 1x Makita Tool Bag  
Beg Alat Makita  
Makita 工具袋

**4** 1x Two Port Multi  
Rapid Charger (DC18RD)  
Pengecas Pantas Dua Port (DC18RD)  
两端快速充电器 (DC18RD)

1x Round Brush (198877-6)  
Berus Bulat 圆刷

1x Flexible Rubber Nozzle (197900-4)  
Muncung Getah Fleksibel 弹性吸嘴

1x Nozzle Assembly (198037-9)  
Komponen Muncung 吸嘴组件

1x Corner Nozzle (198918-8)  
Muncung Sudut 角落吸嘴

1x Flexible Hose (198867-9)  
Hos Fleksibel 软管

10pcs Paper Dust Bag (197902-0)  
Beg Habuk Kertas  
纸制集尘袋

10pcs Filter (198914-6)  
Penapis  
尘袋

## CORDLESS COMBO KIT

Pakej kombo peralatan tanpa kord 充电式工具套装

# DLX3131TX2

**18V**  
**LITHIUM-ION**  
18V Litium-ion | 18V 锂离子

**NEW**  
**BARU** 新

**BL MOTOR**  
Motor tanpa berus 无碳刷马达  
**XPT**  
EXTREME PROTECTION TECHNOLOGY  
Teknologi Perlindungan Ekstrem  
防尘防水滴技术

- 1x DHR242 24mm (15/16")  
**Cordless Combination Hammer**  
Tukul Kombinasi Tanpa Kord 充电式冲击电钻电锤  
1x 5.0Ah Battery (BL1850B)  
Bateri 5.0Ah (BL1850B) 5.0Ah 电池 (BL1850B)

**BL MOTOR**  
Motor tanpa berus 无碳刷马达  
**XPT**  
EXTREME PROTECTION TECHNOLOGY  
Teknologi Perlindungan Ekstrem  
防尘防水滴技术

- 1x DTW285 12.7mm (1/2")  
**Cordless Impact Wrench**  
Perengkuh Impak Tanpa Kord 充电式冲击套筒扳手  
1x 5.0Ah Battery (BL1850B)  
Bateri 5.0Ah (BL1850B) 5.0Ah 电池 (BL1850B)

**BL MOTOR**  
Motor tanpa berus 无碳刷马达

**XPT**  
EXTREME PROTECTION TECHNOLOGY  
Teknologi Perlindungan Ekstrem  
防尘防水滴技术

- 1x DGA404 100mm (4")  
**Cordless Angle Grinder**  
Pengisar Sudut Tanpa Kord 角向磨光机  
1x 5.0Ah Battery (BL1850B)  
Bateri 5.0Ah (BL1850B) 5.0Ah 电池 (BL1850B)  
1x Depressed Centre Wheel (A-80852)  
Cakera Abrasif 磨片

- 1x Two Port Multi  
**Rapid Charger (DC18RD)**  
Pengecas Pantas Dua Port (DC18RD)  
两端快速充电器 (DC18RD)

- 1x Makita Tool Bag  
(831271-6)  
Beg Alat Makita  
Makita 工具袋

## CORDLESS COMBO KIT

Pakej kombo peralatan tanpa kord 充电式工具套装

# DLX2218X

**18V**  
**LITHIUM-ION**  
18V Litium-ion | 18V 锂离子

- 1x Rapid Charger (DC18RC)  
Pengecas Pantas (DC18RC)  
快速充电器 (DC18RC)

- 1x DHR165 16mm (5/8")  
**Cordless Rotary Hammer**  
Tukul Berputar Tanpa Kord 充电式电锤  
1x 3.0Ah Battery (BL1830B)  
Bateri 3.0Ah (BL1830B) 3.0Ah 电池 (BL1830B)

- 1x DTW190 12.7mm (1/2")  
**Cordless Impact Wrench**  
Perengkuh Impak Tanpa Kord  
充电式冲击套筒扳手  
1x 3.0Ah Battery (BL1830B)  
Bateri 3.0Ah (BL1830B) 3.0Ah 电池 (BL1830B)

- 1x Makita Aluminium  
Suitcase  
Beg Bimbit Aluminium Makita  
Makita 铝合金工具箱

## CORDLESS COMBO KIT

Pakej kombo peralatan tanpa kord 充电式工具套装

# DLX2220

**18V**  
**LITHIUM-ION**  
18V Litium-ion | 18V 锂离子

- 1x Rapid Charger (DC18RC)  
Pengecas Pantas (DC18RC)  
快速充电器 (DC18RC)

- 1x DTD155 Cordless  
Impact Driver  
Pemutar Skru Impak Tanpa Kord  
充电式冲击螺丝起子机  
1x 3.0Ah Battery (BL1830B)  
Bateri 3.0Ah (BL1830B) 3.0Ah 电池 (BL1830B)

- 1x DDF483 13mm (1/2")  
**Cordless Driver Drill**  
Gerudi Pemutar Skru Tanpa Kord  
充电式螺丝起子电钻  
1x 3.0Ah Battery (BL1830B)  
Bateri 3.0Ah (BL1830B) 3.0Ah 电池 (BL1830B)

- 1x Makita Tool Bag  
Beg Alat Makita  
Makita 工具袋



**CORDLESS COMBO KIT**  
Pakej kombo peralatan tanpa kord 充电式工具套装

# DK0090SWX1

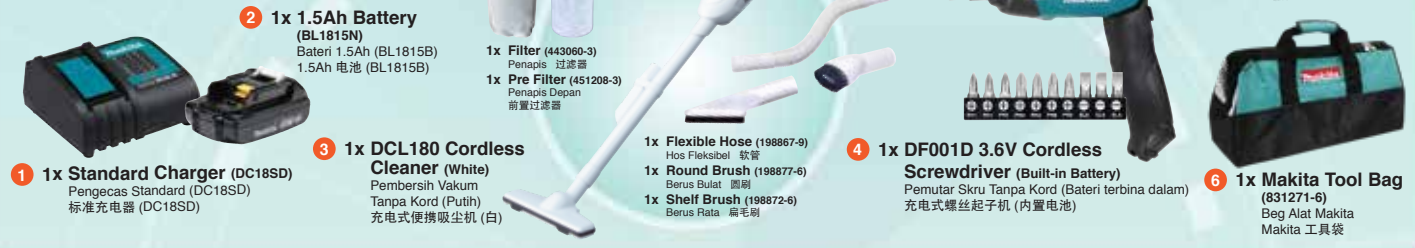

**1** 1x Standard Charger (DC18SD)  
Pengecas Standard (DC18SD)  
标准充电器 (DC18SD)

**2** 1x 1.5Ah Battery (BL1815N)  
Bateri 1.5Ah (BL1815B)  
1.5Ah 电池 (BL1815B)

**3** 1x DCL180 Cordless Cleaner (White)  
Pembersih Vakum Tanpa Kord (Putih)  
充电式便携吸尘器 (白)

**4** 1x DF001D 3.6V Cordless Screwdriver (Built-in Battery)  
Pemutar Skru Tanpa Kord (Bateri terbina dalam)  
充电式螺丝起子机 (内置电池)

**5** 1x ADP07 Adapter for USB  
Pengecas  
充电器

**6** 1x Makita Tool Bag (831271-6)  
Beg Alat Makita  
Makita 工具袋

**18V LITHIUM-ION**  
18V Lithium-ion | 18V锂离子

1x Filter (443060-3)  
Penapis 过滤器

1x Pre Filter (451208-3)  
Penapis Depan  
前置过滤器

1x Flexible Hose (198867-9)  
Hos Fleksibel 软管

1x Round Brush (198877-6)  
Berus Bulat 圆刷

1x Shelf Brush (198872-6)  
Berus Rata 扁毛刷

**CORDLESS COMBO KIT**  
Pakej kombo peralatan tanpa kord 充电式工具套装

# DK0089WX1



**1** 1x Standard Charger (DC10WD)  
Pengecas Standard (DC10WD)  
标准充电器 (DC10WD)

**2** 1x 1.5Ah Battery (BL1016)  
Bateri 1.5Ah (BL1016)  
1.5Ah 电池 (BL1016)

**3** 1x CL107FD Cordless Cleaner (White)  
Pembersih Vakum Tanpa Kord (Putih)  
充电式便携吸尘器 (白)

**4** 1x DF001D 3.6V Cordless Screwdriver (Built-in Battery)  
Pemutar Skru Tanpa Kord (Bateri terbina dalam)  
充电式螺丝起子机 (内置电池)

**5** 1x ADP07 Adapter for USB  
Pengecas  
充电器

**6** 1x Makita Tool Bag (831271-6)  
Beg Alat Makita  
Makita 工具袋

**12Vmax LITHIUM-ION**  
12V Lithium-ion | 12V锂离子

5pcs Paper Filter (194566-1)  
Penapis Kartas  
纸制尘袋

1x Flexible Hose (198867-9)  
Hos Fleksibel 软管

1x Round Brush (198877-6)  
Berus Bulat 圆刷

1x Shelf Brush (198872-6)  
Berus Rata 扁毛刷

**CORDLESS COMBO KIT**  
Pakej kombo peralatan tanpa kord 充电式工具套装

# CLX224

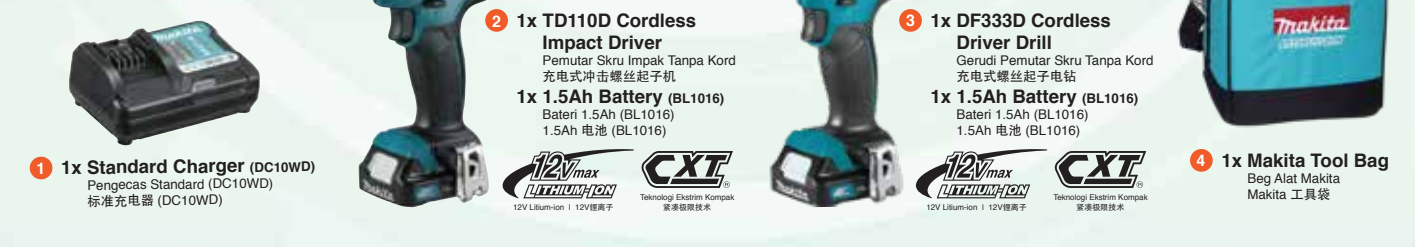

**1** 1x Standard Charger (DC10WD)  
Pengecas Standard (DC10WD)  
标准充电器 (DC10WD)

**2** 1x TD110D Cordless Impact Driver  
Pemutar Skru Impak Tanpa Kord  
充电式冲击螺丝起子机

**3** 1x DF333D Cordless Driver Drill  
Gerudi Pemutar Skru Tanpa Kord  
充电式螺丝起子电钻

**4** 1x Makita Tool Bag  
Beg Alat Makita  
Makita 工具袋

**1.5Ah Battery (BL1016)**  
Bateri 1.5Ah (BL1016)  
1.5Ah 电池 (BL1016)

**12Vmax LITHIUM-ION**  
12V Lithium-ion | 12V锂离子

**CXT**  
Teknologi Ekstrim Kompak  
家康极限技术

**CORDLESS COMBO KIT**  
Pakej kombo peralatan tanpa kord 充电式工具套装

# CLX224X1

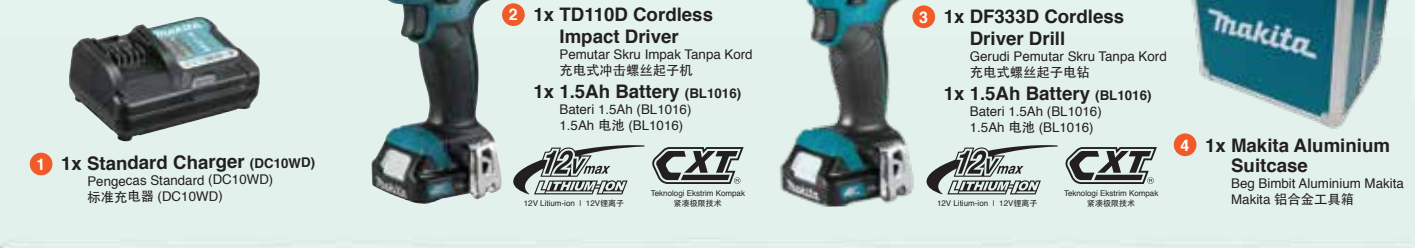

**1** 1x Standard Charger (DC10WD)  
Pengecas Standard (DC10WD)  
标准充电器 (DC10WD)

**2** 1x TD110D Cordless Impact Driver  
Pemutar Skru Impak Tanpa Kord  
充电式冲击螺丝起子机

**3** 1x DF333D Cordless Driver Drill  
Gerudi Pemutar Skru Tanpa Kord  
充电式螺丝起子电钻

**4** 1x Makita Aluminium Suitcase  
Beg Bimbit Aluminium Makita  
Makita 铝合金工具箱

**1.5Ah Battery (BL1016)**  
Bateri 1.5Ah (BL1016)  
1.5Ah 电池 (BL1016)

**12Vmax LITHIUM-ION**  
12V Lithium-ion | 12V锂离子

**CXT**  
Teknologi Ekstrim Kompak  
家康极限技术

**CORDLESS COMBO KIT**  
Pakej kombo peralatan tanpa kord 充电式工具套装

# CLX206AX2



**1** 1x Standard Charger (DC10WD)  
Pengecas Standard (DC10WD)  
标准充电器 (DC10WD)

**2** 1x TM30D Cordless Multi Tool  
Mesin Pemotong Pelbagai Guna Tanpa Kord  
充电式多功能切割磨机

**3** 1x DF331D Cordless Driver Drill  
Gerudi Pemutar Skru Tanpa Kord  
充电式螺丝起子电钻

**4** 1x Makita Tool Bag (831253-8)  
Beg Alat Makita  
Makita 工具袋

**2.0Ah Battery (BL1021B)**  
Bateri 2.0Ah (BL1021B)  
2.0Ah 电池 (BL1021B)

**1x Accessories Set**  
Set Aksesori 配件套装

**1x Phillips Bit**  
Mata Skru 螺丝批头

**12Vmax LITHIUM-ION**  
12V Lithium-ion | 12V锂离子

**CXT**  
Teknologi Ekstrim Kompak  
家康极限技术

**XGT**

# 40V Li-ion max

**High Power**

Kuasa Tinggi 高马力

**Durability**

Ketahanan 超耐用

**Digital Communication**

Sistem Pintar 智能系统



**Battery**

BL4025 ( 2.5Ah )

BL4040 ( 4.0Ah )

**Charger**

DC40RA

ADP10

Adapter for LXT Battery





**DF001G**

**HP001G**

**Max Fastening Torque**  
Tenaga Pemutaran Pengancing Maksimum 最大紧固扭力  
**140 N·m**



**41 electronic clutch settings**

A wider range of heavy-duty applications achieved by increasing clutch settings  
41 tetapan clutch elektronik (21 tahap dalam mod tinggi) Merealisasikan rangkaian aplikasi tugas berat yang lebih luas dengan meningkatkan tetapan clutch  
41级电子离合器设置  
(高级模式下21级设置)通过增加离合器档位位置实现更广泛的重型应用

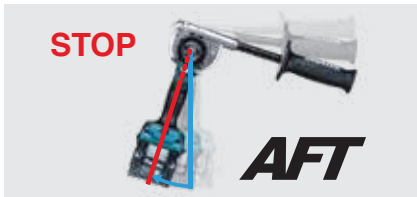

**Active Feedback sensing Technology**

Torque limiter turns the motor off if the tool is suddenly forced to lock  
Teknologi Sensor Maklum Balas Automatik  
Sekiranya alat ini terkunci secara tidak sengaja, pembatas tork secara automatik akan mematikan motor  
AFT 主动反馈传感技术  
如果工具被意外锁死, 扭矩限制器会自动关闭电机



\*HP001G: 182mm

**Compact overall length -24mm**

**DF001GD201 13mm (1/2")**  
RM 5,047

**Cordless Driver Drill**  
Gerudi Pemutar Skru Tanpa Kord  
充电式螺丝起子电钻



• Excellent performance in continuous heavy duty applications

Standard Equipment: Side Grip, Belt Clip, (+/-) Bit, Bit Holder  
• D201: 1x Fast Charger, 2x 2.5Ah Battery



<b>Capacity</b> Kapasiti 能力	Steel: 20mm (13/16")   Wood (Auger-Bit): 50mm (2")   Wood (Self-Feed Bit): 76mm (3")   Wood (Hole Saw): 152mm (6")   Siding Board: 220mm (8-5/8")
<b>Chuck Capacity</b> Kapasiti Chuck 夹头能力	1.5 - 13mm (1/16" - 1/2")
<b>No Load Speed (RPM)</b> Kelajuan Tanpa Beban 回转数	High: 0 - 2,600   Low: 0 - 650
<b>Max Fastening Torque</b> Tenaga Pemutaran Pengancing Maksimum 最大紧固扭力	Hard: 140N·m (1,240in.lbs.)   Soft: 68N·m (600 in.lbs.)
<b>Max Lock Torque</b> Pemutaran Tenaga Maksimum 最大扭矩	125N·m (1,100in.lbs.)
<b>Max Peak Torque</b> Pemutaran Maksimum 最大值扭力	141N·m
<b>Dimensions (L x W x H)</b> Dimensi 体积	181x86x275mm (7-1/8"x3-3/8"x10-7/8")
<b>Net Weight</b> Berat Bersih 净重	2.7 - 3.0kg (5.9 - 6.6lbs.)

**HP001GD201 13mm (1/2")**  
RM 5,100

**Cordless Hammer Driver Drill**  
Tukul Pemutar Skru Bergerudi Tanpa Kord  
充电式冲击螺丝起子电钻



• Excellent performance in continuous heavy duty applications

Standard Equipment: Depth Gauge, Side Grip, Belt Clip, (+/-) Bit, Bit Holder  
• D201: 1x Fast Charger, 2x 2.5Ah Battery



<b>Capacity</b> Kapasiti 能力	Steel: 20mm (13/16")   Wood (Auger-Bit): 50mm (2")   Wood (Self-Feed Bit): 76mm (3")   Wood (Hole Saw): 152mm (6")   Siding Board: 220mm (8-5/8")   Masonry: 20mm (13/16")
<b>Chuck Capacity</b> Kapasiti Chuck 夹头能力	1.5 - 13mm (1/16" - 1/2")
<b>Impacts Per Minute (IPM)</b> Impak Per Minit 冲击数	High: 0 - 39,000   Low: 0 - 9,750
<b>No Load Speed (RPM)</b> Kelajuan Tanpa Beban 回转数	High: 0 - 2,600   Low: 0 - 650
<b>Max Fastening Torque</b> Tenaga Pemutaran Pengancing Maksimum 最大紧固扭力	Hard: 140N·m (1,240in.lbs.)   Soft: 68N·m (600 in.lbs.)
<b>Max Lock Torque</b> Pemutaran Tenaga Maksimum 最大扭矩	125N·m (1,100in.lbs.)
<b>Max Peak Torque</b> Pemutaran Maksimum 最大值扭力	141N·m
<b>Dimensions (L x W x H)</b> Dimensi 体积	182x86x275mm (7-1/8"x3-3/8"x10-7/8")
<b>Net Weight</b> Berat Bersih 净重	2.7 - 3.0kg (6.0 - 6.6lbs.)

\* All list price shown are for reference only (exclude SST).

\* Semua harga yang ditunjukkan adalah untuk rujukan sahaja (tidak termasuk SST). 所有显示的建议零售价仅供参考 (不包括SST)。

**Cordless**  
Tanpa Kord 充电式

**LED Flashlight**  
Lampu Suli LED LED照明灯

**Vacuum Cleaner**  
Pembersih Vakuum 吸尘器

**Drilling / Fastening**  
Gerudi / Pengangut 钻孔 / 紧固

**Impact Drilling / Demolition**  
Gerudi / Pembongkaran 冲击钻孔 / 拆毁

**Cutting**  
Pemotong 切割

**Grinding / Sanding**  
Pengamiran / Pemoles 打磨 / 砂磨

**Sawing**  
Gergaji 锯切

**Planing / Routing**  
Pengamiran / Tumpang 刨削 / 压花

**Others**  
Lain-lain 其他

**Outdoor Power Equipment**  
Alatan Kuasa Luar 户外动力设备

**Makita**  
100 YEARS



Cordless Target Kord Tanpa Kord  
 LED Flashlight Lampu Salih LED LED 照明灯  
 Vacuum Cleaner Pemilauhi Vakuu 吸尘器  
 Drilling / Fastening Dremel / Pengikat 钻头 / 螺丝  
 Impact Drilling / Demolition Ganda / Perusak 起工钻头 / 拆墙加工  
 Cutting Pemotong 切割机  
 Grinding / Sanding Pengisar / Poles 磨削 / 打磨  
 Sawing Gergaji 电锯  
 Planing / Routing Pengisar / Tampam 刨削 / 雕刻  
 Others Lain-lain 其他  
 Outdoor Power Equipment Alatan Korsa Luar 园机-户外



**TD001G**



**TW001G**

**TD001G**

**10 Tightening modes**  
 10 mod pengetatan 10种紧固模式  
 4-speed power selection  
 +  
 6-Assist modes

Drive  $\phi 6.5 \times 120\text{mm}$  metal fastening screws

<b>TD001G</b>	<b>115</b>	<b>2.5s</b>
Predecessor Model 18V	<b>100</b>	
Low	Fastening speed	High

**Max Fastening Torque**  
 Tenaga Pemutaran Pengancing Maksimum 最大紧固扭力  
**220 N·m**

**TW001G**



**Usability improvement**  
 Impact power selection: 4 stages  
 Forward and Reverse Rotation auto stop  
 Forward: 3 mode / Reverse: 3 mode  
 4 tahap pilihan daya impak  
 Kelajuan dan daya hentakan yang sesuai dapat dipilih mengikut keperluan  
 4个等级冲击力选择  
 可根据实际工作的需要选择合适的速度和冲击力

**TD001GD201** RM 4,525 | **TD001GZ** RM 1,717

**Cordless Impact Driver**  
 Pemutar Skru Impak Tanpa Kord  
 充电式冲击螺丝起子机



- 4-speed power selection plus 6 Assist modes (2 T-modes, 1 Wood mode, 3 Bolt modes)



- Standard Equipment: Belt Clip
- D201: 1x Fast Charger, 2x 2.5Ah Battery
  - Z: Without Charger, Battery & Carrying Case



<b>Capacity</b> Kapasiti 能力	<b>Machine Screw: M4 - M8 (5/32" - 5/16")</b> <b>Standard Bolt: M5 - M16 (3/16" - 5/8")</b> <b>High Strength Bolt: M5 - M14 (3/16" - 9/16")</b> <b>Coarse thread (in length): 22 - 125 mm (7/8" - 4-7/8")</b> 6.35 mm (1/4")
<b>Hex Shank</b> Batang Heksagon 六角柄	
<b>No Load Speed (RPM)</b> Kelajuan Tanpa Beban 回转数	Max / Hard / Med / Soft / Wood / Bolt (1) / Bolt (2) / Bolt (3) / T (1) / T (2) mode: 0 - 3,700 / 3,200 / 2,100 / 1,100 / 1,800 / 2,500 / 3,700 / 3,700 / 2,400 / 3,700
<b>Impacts Per Minute (IPM)</b> Impak Per Minit 冲击数	Max / Hard / Med / Soft / Wood / Bolt (1) / Bolt (2) / Bolt (3) / T (1) / T (2) mode: 0 - 4,400 / 3,600 / 2,600 / 1,100 / 4,400 / N/A / 4,400 / 4,400 / N/A / 2,600
<b>Max Fastening Torque</b> Tenaga Pemutaran Pengancing Maksimum 最大紧固扭力	<b>220N·m (1,950in.lbs.)</b>
<b>Fastening Torque</b> Tenaga Pemutaran Pengancing 扭力	<b>Hard: 170N·m(1,510in.lbs.)</b>   <b>Med: 50N·m(440in.lbs.)</b>   <b>Soft: 20N·m (180in.lbs.)</b>
<b>Dimensions (L x W x H)</b> Dimensi 体积	<b>120x86x245mm</b> (4-3/4"x3-3/8"x9-5/8")
<b>Net Weight</b> Berat Bersih 净重	<b>1.7 - 2.0kg (3.7 - 4.4lbs.)</b>

**TW001GM201** 19mm (3/4")  
 RM 6,568

**Cordless Impact Wrench**  
 Perengkuh Impak Tanpa Kord  
 充电式冲击套筒扳手



- Higher torque and more compact than DTW1001



- Standard Equipment: Belt Clip
- M201: 1x Fast Charger, 2x 4.0Ah Battery



<b>Fastening Capacities</b> Kapasiti 能力	<b>Standard Bolt: M12 - M36 (1/2" - 1-7/16")</b> <b>High Strength Bolt: M10 - M27 (3/8" - 1-1/16")</b> <b>19 mm (3/4")</b>
<b>Square Drive</b> Batang Segi Empat 四方柄	
<b>No Load Speed (RPM)</b> Kelajuan Tanpa Beban 回转数	Max: 0 - 1,800   Hard: 1,400   Mid: 1,150   Soft: 950
<b>Impacts Per Minute (IPM)</b> Impak Per Minit 冲击数	Max: 0 - 2,500   Hard: 2,400   Mid: 2,200   Soft: 1,900
<b>Max Fastening Torque</b> Tenaga Pemutaran Pengancing Maksimum 最大紧固扭力	<b>1,800N·m (1,330ft.lbs.)</b>
<b>Nut-Busting Torque</b> Tork Pengetatan Bolt 螺栓拧紧扭力	<b>2,050N·m (1,510ft.lbs.)</b>
<b>Dimensions (L x W x H)</b> Dimensi 体积	<b>217x94x297mm</b> (8-1/2"x3-11/16"x11-3/4")
<b>Net Weight</b> Berat Bersih 净重	<b>3.9 - 4.2kg (8.6 - 9.3lbs.)</b>



\* All list price shown are for reference only (exclude SST).

\* Semua harga yang ditunjukkan adalah untuk rujukan sahaja (tidak termasuk SST). 所有显示的建议零售价仅供参考 (不包括SST)。



# Cordless Combination Hammer

Tukul Kombinasi Tanpa Kord 充电式冲击钻锤



**HEPA filter**

**Filter cleaning mechanism**

Mekanisme pembersihan penapis  
过滤器清洁机构

**Built-in DC motor for dust collection**

Motor DC terbita dalam untuk pengumpulan habuk  
内置直流除尘电机

Light weight  
Ringan 轻量  
**3.9kg**  
with BL4025  
2.5Ah Battery



Vibration Level Tahap getaran 振动等级 **7.0m/s<sup>2</sup>**



**Active Feedback Sensing Technology**  
Teknologi Sensor Maklum Balas Automatik  
自动回饋感应科技  
(HR001G / HR002G only)

**Accessories (Optional)**  
Aksesori 配件

**Dust extraction system set**  
Set sistem pengumpulan habuk  
集尘系统

**DX12**  
for HR001G / HR003G  
Part No. 191E52-3



**DX14**  
for HR002G  
Part No. 191E58-1

**HR001GM201** 28mm (1-1/8")  
RM 6,373

**Cordless Combination Hammer**  
Tukul Kombinasi Tanpa Kord  
充电式冲击钻锤

• Auto-start Wireless System (AWS) connects to vacuum cleaner with Bluetooth

Standard Equipment: Side Grip, Depth Gauge, Cloth, Grease Vessel (194683-7)

• M201: 1x Fast Charger, 2x 4.0Ah Battery



Models and specs may vary by country



**Impact Energy**  
Kekuatan Impak 单次最大锤击力

**Capacity**  
Kapasiti 能力

**Impact Per Minute (IPM)**  
Impak Per Minit 冲击数

**No Load Speed (RPM)**  
Kelajuan Tanpa Beban 回转数

**Dimensions (L x W x H)**  
Dimensi 体积

**Net Weight**  
Berat Bersih 净重

EPTA-Procedure 05/2009: 2.8J  
Our experimental conditions: 3.2J  
Concrete: 28mm(1-1/8") | Steel: 13mm(1/2") |  
Wood: 32mm(1-1/4") | Core Bit: 54mm(2-1/8") |  
Diamond Core Bit (Dry Type): 65mm (2-9/16")

0 - 5,000

0 - 980

358x102x232mm

(14-1/8"x4"x9-1/8")

3.9 - 4.6kg (8.6 - 10.1lbs.)

**HR002GM201** 28mm (1-1/8")  
RM 6,770

**Cordless Combination Hammer**  
Tukul Kombinasi Tanpa Kord  
充电式冲击钻锤

• Auto-start Wireless System (AWS) connects to vacuum cleaner with Bluetooth

Standard Equipment: Side Grip, Depth Gauge, Cloth, Grease Vessel (194683-7), Drill Chuck (199139-5)

• M201: 1x Fast Charger, 2x 4.0Ah Battery



Models and specs may vary by country



**Impact Energy**  
Kekuatan Impak 单次最大锤击力

**Capacity**  
Kapasiti 能力

**Impact Per Minute (IPM)**  
Impak Per Minit 冲击数

**No Load Speed (RPM)**  
Kelajuan Tanpa Beban 回转数

**Dimensions (L x W x H)**  
Dimensi 体积

**Net Weight**  
Berat Bersih 净重

EPTA-Procedure 05/2009: 2.9J  
Concrete: 28mm(1-1/8") | Steel: 13mm(1/2") |  
Wood: 32mm(1-1/4") | Core Bit: 54mm(2-1/8") |  
Diamond Core Bit (Dry Type): 65mm (2-9/16")

0 - 5,000

0 - 980

389x102x232mm

(15-1/4"x4"x9-1/8")

4.1 - 4.6kg (9.0 - 10.1lbs.)

**HR003GM201** | **HR003GZ** 28mm (1-1/8")  
RM 5,898 | RM 2,725

**Cordless Combination Hammer**  
Tukul Kombinasi Tanpa Kord  
充电式冲击钻锤

• 3-mode operation for "Rotation Only", "Hammering with Rotation" or "Hammering Only"

Standard Equipment: Side Grip, Depth Gauge

• M201: 1x Fast Charger, 2x 4.0Ah Battery  
• Z: Without Charger, Battery & Carrying Case

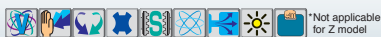

Models and specs may vary by country



**Impact Energy**  
Kekuatan Impak 单次最大锤击力

**Capacity**  
Kapasiti 能力

**Impact Per Minute (IPM)**  
Impak Per Minit 冲击数

**No Load Speed (RPM)**  
Kelajuan Tanpa Beban 回转数

**Dimensions (L x W x H)**  
Dimensi 体积

**Net Weight**  
Berat Bersih 净重

EPTA-Procedure 05/2009: 2.8J  
Our experimental conditions: 3.2J  
Concrete: 28mm(1-1/8") | Steel: 13mm(1/2") |  
Wood: 32mm(1-1/4") | Core Bit: 54mm(2-1/8") |  
Diamond Core Bit (Dry Type): 65mm (2-9/16")

0 - 5,000

0 - 980

358x121x232mm

(14-1/8"x4-3/4"x9-1/8")

3.9 - 4.6kg (8.6 - 10.1lbs.)

\* All list price shown are for reference only (exclude SST).

\* Semua harga yang ditunjukkan adalah untuk rujukan sahaja (tidak termasuk SST). 所有显示的建议零售价仅供参考 (不包括SST)。

Cordless  
Target: 4000 3000

LED Flashlight  
Lampu Suhu LED  
LED 白光

Vacuum Cleaner  
Pembersih Vakuum  
吸尘器

Drilling / Fastening  
Gantuk / Pasang  
钻孔 / 紧固

Impact Drilling / Demolition  
Gantuk / Hancurkan  
冲击钻孔 / 拆除

Cutting  
Memotong  
切割

Grinding / Sanding  
Pergasilan / Poles  
打磨 / 砂磨

Sanding  
Gantuk  
打磨

Planing / Routing  
Pergasilan / Tumpang  
刨平 / 嵌条

Others  
Lain-lain  
其他

Outdoor Power Equipment  
Alatan Kuat Luar  
户外动力工具

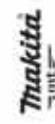



# Cordless Angle Grinder

Pengisar Sudut Tanpa Kord 充电式角向磨光机

**Delivers same power as 1,000W corded grinders**

Memberi kuasa yang sama dengan Pengisar Sudut 1,000W  
提供与1,000W有线打磨机相同的功率

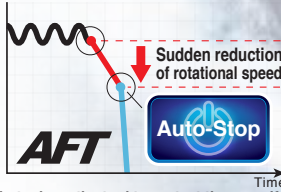

**Shuts down the tool to protect the user, if the rotation speed suddenly slows down**  
Alat kuasa akan berhenti secara automatic untuk melindungi pengguna jika kelajuan putaran tiba-tiba melambat  
若旋转速度突然降低，工具将自动关闭以保护使用者



Active Feedback Sensing Technology  
Teknologi Sensor Maklum Balas Automatik  
自动回馈感应科技

Model No. 型号		No Load Speed (rpm) 空载转速 回转数	Switch 开关	BL MOTOR	XPT	AFT	BRAKE	AWS	Anti-restart function 防重启功能
100mm	125mm								
GA003G	GA005G	8,500	Slide	•	•	•	•	•	•
GA011G	GA013G	8,500	Paddle	•	•	•	•	•	•
GA021G	GA023G	3,000 - 8,500	Slide	•	•	•	•	•	•
GA027G	GA029G	3,000 - 8,500	Paddle	•	•	•	•	•	•

**GA003GM201 | GA003GD201 100mm (4")**  
RM 4,867 | RM 4,502

**Cordless Angle Grinder**  
Pengisar Sudut Tanpa Kord  
充电式角向磨光机



**Top Slide Switch**

Suis Gelangsar Atas 顶部滑动开关  
**Convenient for left & right handed**  
Mudah diguna dengan tangan kiri atau kanan 方便左右手



- Excellent in continuous heavy-duty work



**Standard Equipment:** Grinding Wheel (A-80852), Wheel Cover, Side Grip, Lock Nut Wrench

- M201: 1x Fast Charger, 2x 4.0Ah Battery
- D201: 1x Fast Charger, 2x 2.5Ah Battery



\*Not applicable for Z model



<b>Wheel Diameter</b> Diameter Roda 轮片直径	100mm (4")
<b>Hole Diameter</b> Diameter Lubang 孔直径	16mm (5/8")
<b>Max Wheel Thickness</b> Ketebalan Roda Maksimum 最大轮片厚度	6.4mm (1/4")
<b>No Load Speed (RPM)</b> Kelajuan Tanpa Beban 回转数	8,500
<b>Dimensions (L x W x H)</b> Dimensi 体积	398x117x150mm (15-5/8"x4-5/8"x5-7/8")
<b>Net Weight</b> Berat Bersih 净重	2.8 - 3.3kg (6.2 - 7.3lbs.)

**GA011GM201 | GA011GD201 100mm (4")**  
RM 4,960 | RM 4,595

**Cordless Angle Grinder**  
Pengisar Sudut Tanpa Kord  
充电式角向磨光机

**Paddle Switch**

Suis Pemicu 扳机开关



- Genuine solution for high demand industrial applications



**Standard Equipment:** Grinding Wheel (A-80852), Wheel Cover, Side Grip, Lock Nut Wrench

- M201: 1x Fast Charger, 2x 4.0Ah Battery
- D201: 1x Fast Charger, 2x 2.5Ah Battery



\*Not applicable for Z model



<b>Wheel Diameter</b> Diameter Roda 轮片直径	100mm (4")
<b>Hole Diameter</b> Diameter Lubang 孔直径	16mm (5/8")
<b>Max Wheel Thickness</b> Ketebalan Roda Maksimum 最大轮片厚度	6.4mm (1/4")
<b>No Load Speed (RPM)</b> Kelajuan Tanpa Beban 回转数	8,500
<b>Dimensions (L x W x H)</b> Dimensi 体积	398x117x150mm (15-5/8"x4-5/8"x5-7/8")
<b>Net Weight</b> Berat Bersih 净重	2.8 - 3.4kg (6.2 - 7.5lbs.)

**GA021GM201 | GA021GD201 | GA021GZ 100mm (4")**  
RM 5,055 | RM 4,690 | RM 1,883

**Cordless Angle Grinder**  
Pengisar Sudut Tanpa Kord  
充电式角向磨光机

**Top Slide Switch**

Suis Gelangsar Atas 顶部滑动开关  
**Convenient for left & right handed**  
Mudah diguna dengan tangan kiri atau kanan 方便左右手



- Auto-start Wireless System (AWS) connects to compatible vacuum cleaners with Bluetooth



**Standard Equipment:** Grinding Wheel (A-80852), Wheel Cover, Side Grip, Lock Nut Wrench

- M201: 1x Fast Charger, 2x 4.0Ah Battery
- D201: 1x Fast Charger, 2x 2.5Ah Battery
- Z: Without Charger, Battery & Carrying Case



\*Not applicable for Z model



<b>Wheel Diameter</b> Diameter Roda 轮片直径	100mm (4")
<b>Hole Diameter</b> Diameter Lubang 孔直径	16mm (5/8")
<b>Max Wheel Thickness</b> Ketebalan Roda Maksimum 最大轮片厚度	6.4mm (1/4")
<b>No Load Speed (RPM)</b> Kelajuan Tanpa Beban 回转数	3,000 - 8,500
<b>Dimensions (L x W x H)</b> Dimensi 体积	413x117x150mm (16-1/4"x4-5/8"x5-7/8")
<b>Net Weight</b> Berat Bersih 净重	2.8 - 3.4kg (6.2 - 7.5lbs.)

\* All list price shown are for reference only (exclude SST).

\* Semua harga yang ditunjukkan adalah untuk rujukan sahaja (tidak termasuk SST). 所有显示的建议零售价仅供参考 (不包括SST)。

Cordless Target Kord 无绳式  
LED Flashlight Lampu Suluh LED LED 照明灯  
Vacuum Cleaner Pemilauhi (VACUUM) 吸尘器  
Drilling / Fastening Dremel / Pengikat 钻 / 紧固  
Impact Drilling / Demolition Ganda / Pemusnah 冲击钻 / 拆除加工  
Cutting Pemotong 切割  
Grinding / Sanding Pengisar / Pasir 磨 / 打磨  
Sawing Gergaji 电锯  
Planing / Routing Pengisar / Tangkapan 刨 / 雕刻  
Others Lain-lain 其他  
Outdoor Power Equipment Alatan Kuasa Luar 户外电力设备





**GA027GM201** | **GA027GD201** | **GA027GZ** 100mm (4")  
 RM 5,152 | RM 4,787 | RM 1,980

**Cordless Angle Grinder**  
 Pengisar Sudut Tanpa Kord  
 充电式角向磨光机

**Paddle Switch**  
 Suis Pemicu 拨机开关



- Auto-start Wireless System (AWS) connects to compatible vacuum cleaners with Bluetooth

**Standard Equipment:** Grinding Wheel (A-80852), Wheel Cover, Side Grip, Lock Nut Wrench

- M201: 1x Fast Charger, 2x 4.0Ah Battery
- D201: 1x Fast Charger, 2x 2.5Ah Battery
- Z: Without Charger, Battery & Carrying Case



\*Not applicable for Z model



<b>Wheel Diameter</b> Diameter Roda 轮片直径	100mm (4")
<b>Hole Diameter</b> Diameter Lubang 孔直径	16mm (5/8")
<b>Max Wheel Thickness</b> Ketebalan Roda Maksimum 最大轮片厚度	6.4mm (1/4")
<b>No Load Speed (RPM)</b> Kelajuan Tanpa Beban 回转数	3,000 - 8,500
<b>Dimensions (L x W x H)</b> Dimensi 体积	413x117x150mm (16-1/4"x4-5/8"x5-7/8")
<b>Net Weight</b> Berat Bersih 净重	2.9 - 3.4kg (6.4 - 7.5lbs.)

**GA005GM201** | **GA005GD201** 125mm (5")  
 RM 4,865 | RM 4,502

**Cordless Angle Grinder**  
 Pengisar Sudut Tanpa Kord  
 充电式角向磨光机

**Top Slide Switch**  
 Suis Gelang Atas 顶部滑动开关  
 Convenient for left & right handed  
 Mudah diguna dengan tangan kiri atau kanan 方便左右操作



- Genuine solution for high demand industrial applications

**Standard Equipment:** Grinding Wheel (A-80656), Wheel Cover, Side Grip, Lock Nut Wrench

- M201: 1x Fast Charger, 2x 4.0Ah Battery
- D201: 1x Fast Charger, 2x 2.5Ah Battery



\*Not applicable for Z model



<b>Wheel Diameter</b> Diameter Roda 轮片直径	125mm (5")
<b>Hole Diameter</b> Diameter Lubang 孔直径	22.23mm (7/8")
<b>Max Wheel Thickness</b> Ketebalan Roda Maksimum 最大轮片厚度	7.2mm (9/32")
<b>No Load Speed (RPM)</b> Kelajuan Tanpa Beban 回转数	8,500
<b>Dimensions (L x W x H)</b> Dimensi 体积	398x140x156mm (15-5/8"x5-1/2"x6-1/8")
<b>Net Weight</b> Berat Bersih 净重	2.9 - 3.6kg (6.4 - 7.9lbs.)

**GA013GM201** | **GA013GD201** 125mm (5")  
 RM 4,960 | RM 4,595

**Cordless Angle Grinder**  
 Pengisar Sudut Tanpa Kord  
 充电式角向磨光机

**Paddle Switch**  
 Suis Pemicu 拨机开关

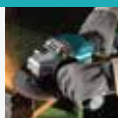

- BL motor to run cooler and more efficiently for longer life

**Standard Equipment:** Grinding Wheel (A-80656), Wheel Cover, Side Grip, Lock Nut Wrench

- M201: 1x Fast Charger, 2x 4.0Ah Battery
- D201: 1x Fast Charger, 2x 2.5Ah Battery



\*Not applicable for Z model



<b>Wheel Diameter</b> Diameter Roda 轮片直径	125mm (5")
<b>Hole Diameter</b> Diameter Lubang 孔直径	22.23mm (7/8")
<b>Max Wheel Thickness</b> Ketebalan Roda Maksimum 最大轮片厚度	7.2mm (9/32")
<b>No Load Speed (RPM)</b> Kelajuan Tanpa Beban 回转数	8,500
<b>Dimensions (L x W x H)</b> Dimensi 体积	398x140x156mm (15-5/8"x5-1/2"x6-1/8")
<b>Net Weight</b> Berat Bersih 净重	3.0 - 3.6kg (6.6 - 7.9lbs.)



GA013G Models and specs may vary by country

**GA023GM201** | **GA023GD201** | **GA023GZ** 125mm (5")  
 RM 5,057 | RM 4,692 | RM 1,885

**Cordless Angle Grinder**  
 Pengisar Sudut Tanpa Kord  
 充电式角向磨光机

**Top Slide Switch**  
 Suis Gelang Atas 顶部滑动开关  
 Convenient for left & right handed  
 Mudah diguna dengan tangan kiri atau kanan 方便左右操作

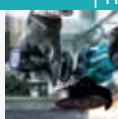

- Auto-start Wireless System (AWS) connects to compatible vacuum cleaners with Bluetooth

**Standard Equipment:** Grinding Wheel (A-80656), Wheel Cover, Side Grip, Lock Nut Wrench

- M201: 1x Fast Charger, 2x 4.0Ah Battery
- D201: 1x Fast Charger, 2x 2.5Ah Battery
- Z: Without Charger, Battery & Carrying Case



\*Not applicable for Z model



<b>Wheel Diameter</b> Diameter Roda 轮片直径	125mm (5")
<b>Hole Diameter</b> Diameter Lubang 孔直径	22.23mm (7/8")
<b>Max Wheel Thickness</b> Ketebalan Roda Maksimum 最大轮片厚度	7.2mm (9/32")
<b>No Load Speed (RPM)</b> Kelajuan Tanpa Beban 回转数	3,000 - 8,500
<b>Dimensions (L x W x H)</b> Dimensi 体积	413x140x156mm (16-1/4"x5-1/2"x6-1/8")
<b>Net Weight</b> Berat Bersih 净重	3.0 - 4.4kg (6.6 - 9.7lbs.)

**GA029GM201** | **GA029GD201** | **GA029GZ** 125mm (5")  
 RM 5,152 | RM 4,787 | RM 1,980

**Cordless Angle Grinder**  
 Pengisar Sudut Tanpa Kord  
 充电式角向磨光机

**Paddle Switch**  
 Suis Pemicu 拨机开关



- Auto-start Wireless System (AWS) connects to compatible vacuum cleaners with Bluetooth

**Standard Equipment:** Grinding Wheel (A-80656), Wheel Cover, Side Grip, Lock Nut Wrench

- M201: 1x Fast Charger, 2x 4.0Ah Battery
- D201: 1x Fast Charger, 2x 2.5Ah Battery
- Z: Without Charger, Battery & Carrying Case



\*Not applicable for Z model



<b>Wheel Diameter</b> Diameter Roda 轮片直径	125mm (5")
<b>Hole Diameter</b> Diameter Lubang 孔直径	22.23mm (7/8")
<b>Max Wheel Thickness</b> Ketebalan Roda Maksimum 最大轮片厚度	7.2mm (9/32")
<b>No Load Speed (RPM)</b> Kelajuan Tanpa Beban 回转数	3,000 - 8,500
<b>Dimensions (L x W x H)</b> Dimensi 体积	413x140x156mm (16-1/4"x5-1/2"x6-1/8")
<b>Net Weight</b> Berat Bersih 净重	3.0 - 4.5kg (6.6 - 9.9lbs.)

\* All list price shown are for reference only (exclude SST).

\* Semua harga yang ditunjukkan adalah untuk rujukan sahaja (tidak termasuk SST). 所有显示的建议零售价仅供参考 (不包括SST)。

Cordless  
Target Area 30x30

LED Flashlight  
Lampu Suhu LED  
LED 闪光灯

Vacuum Cleaner  
Pembersih Vakuum  
吸尘器

Drilling / Fastening  
Ganuli / Pengikat  
钻孔 / 紧固

Impact Drilling / Demolition  
Ganuli / Pemusnah  
冲击钻孔 / 破拆施工

Cutting  
Pemotong  
切割

Grinding / Sanding  
Pengisar / Pemoles  
研磨 / 砂磨

Sawing  
Gergaji  
锯切

Planing / Routing  
Penghalus / Tumpang  
刨削 / 压花

Others  
Lain-lain  
其他

Outdoor Power Equipment  
Alatan Kuat Luar  
园具/户外

Thakita  
TENT



# Cordless Circular Saw

Gergaji Piring Tanpa Kord 充电式圆锯



**Light weight**  
Ringan 轻量  
**4.7kg**  
with BL4040  
4.0Ah Battery



**Compatible with guide rail without adapter**

Boleh bersambung dengan rel panduan tanpa penyesuai 直接连接导轨使用

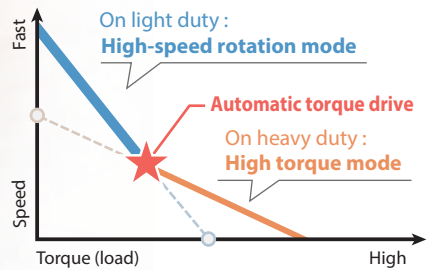

**ADT**  
Automatic Torque Drive Technology  
Teknologi Tork Automatik  
自动扭力驱动科技

**HS004GM201** | **HS004GZ** 190 / 185mm (7-1/2" / 7-1/4")  
RM 6,220 | RM 3,048

**Cordless Circular Saw**  
Gergaji Piring Tanpa Kord  
充电式圆锯



- Lightweight & High Power
- Standard Equipment: TCT Saw Blade (B-62022), Dust Nozzle, Hex Wrench, Guide Rule
- M201: 1x Fast Charger, 2x 4.0Ah Battery
  - Z: Without Charger, Battery & Carrying Case

<b>Blade Diameter</b> Diameter Bilah 锯片直径	190mm (7-1/2")   185mm (7-1/4")
<b>Hole Diameter</b> Diameter Lubang 孔直径	15.88mm (5/8")   20mm (13/16")   30mm (1-3/16")
<b>Max Cutting Capacity</b> Kapasiti Pemotongan Maksimum 最大切割能力	90°: 62.5 / 60 mm (2-7/16" / 2-3/8") 45°: 44.5 / 43 mm (1-3/4" / 1-11/16") 48°: 42 / 41 mm (1-5/8" / 1-5/8")
<b>No Load Speed (RPM)</b> Kelajuan Tanpa Beban 回转速数	6,000
<b>Dimensions (L x W x H)</b> Dimensi 体积	322x210x290mm (12-5/8"x8-1/4"x11-3/8")
<b>Net Weight</b> Berat Bersih 净重	4.4 - 4.7kg (9.7 - 10.4lbs.)



# Cordless Recipro Saw

Gergaji Resipro Tanpa Kord 充电式往复锯

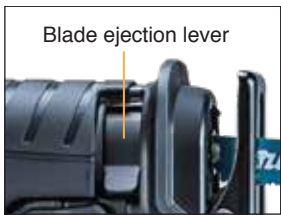

**Light weight**  
Ringan 轻量  
**4.2kg**  
with BL4025  
2.5Ah Battery



**Toolless blade change**  
Penggantian bilah tanpa alat 免工具更换锯片

**JR001GM201** | **JR001GZ**  
RM 5,312 | RM 2,140

**Cordless Recipro Saw**  
Gergaji Resipro Tanpa Kord  
充电式往复锯



- Compact & High Power
- Standard Equipment:  
Recipro Saw Blades 3pcs (B-05038, B-05044, B-05153)
- M201: 1x Fast Charger, 2x 4.0Ah Battery
  - Z: Without Charger, Battery & Carrying Case

<b>Length of Stroke</b> Panjang Strok 冲程长度	32mm (1-1/4")
<b>Strokes Per Minute (SPM)</b> Kelajuan Strok 冲程速度	High: 0 - 3,000   Low: 0 - 2,300
<b>Capacity</b> Kapasiti 能力	Pipe: 130mm (5-1/8") Wood: 255mm (10")
<b>Dimensions (L x W x H)</b> Dimensi 体积	457x88x233mm (18"x3-1/2"x9-1/8")
<b>Net Weight</b> Berat Bersih 净重	4.2 - 4.5kg (9.3 - 9.9lbs.)



\* All list price shown are for reference only (exclude SST).

\* Semua harga yang ditunjukkan adalah untuk rujukan sahaja (tidak termasuk SST). 所有显示的建议零售价仅供参考 (不包括SST)。

Cordless Target Kord 无绳式  
LED Flashlight Lampu Suluh LED LED 照明灯  
Vacuum Cleaner Pemilauhi VAKUUM 吸尘器  
Drilling / Fastening Dronsi / Pengekat 钻式 / 螺柱  
Impact Drilling / Demolition Gergaji / Pemusnah 起工钻式 / 拆墙加工  
Cutting Pemotong 切机  
Grinding / Sanding Pengisar / Pasir 磨削 / 砂磨  
Sawing Gergaji 锯切  
Planing / Routing Pengisar / Tampam 刨削 / 刨床  
Others Lain-lain 其他  
Outdoor Power Equipment Alatan Korsa Luar 园机-户外







Li-ion Ah 6.0 5.0 4.0 3.0 2.0 1.5

# Cordless Rotary Hammer

Tukul Putar Tanpa Kord 充电式电钻

## Accessories (Optional)

Aksesori 配件



Dust Extractor Attachment Set  
Part No. 196536-6



VIDEO CLIP  
Models and specs may vary by country  
DHR400N

**DHR400ZKN** 40mm (1-9/16")  
RM 5,552

## Cordless Rotary Hammer

Tukul Putar Tanpa Kord

充电式电钻



- High power and excellent performance

Standard Equipment: Side Handle, Side Grip, Depth Gauge, Bit Grease (194683-7), Cleaning Cloth

• ZKN: Without Charger & Battery



<b>Impact Energy</b> Kekuatan Impak 单次最大锤击力	EPTA-Procedure 05/2009: 8.0J Our experimental conditions: 11.4J
<b>Capacity</b> Kapasiti 能力	Concrete (TCT Bit): 40mm (1-9/16") Concrete (Core Bit): 105mm (4-1/8")
<b>Impacts Per Minute (IPM)</b> Impak Per Minit 冲击数	1,450 - 2,900
<b>No Load Speed (RPM)</b> Kelajuan Tanpa Beban 回转数	250 - 500
<b>Dimensions (L x W x H)</b> Dimensi 体积	473x120x285mm (18-5/8"x4-3/4"x11-1/4")
<b>Net Weight</b> Berat Bersih 净重	7.3 - 8.1kg (16.1 - 17.9lbs.)
<b>Work Amount (approx.)</b> Jumlah Kerja 工作量	25 holes with BL1850B x2 Concrete Grade 40 D18mm x 140mm Depth

# Cordless Combination Hammer

Tukul Kombinasi Tanpa Kord 充电式冲击电钻电锤

## Accessories (Optional)

Aksesori 配件



HEPA Filter  
Part No. 199557-7

Dust cup  
Part No. 195173-3

Dust case  
Part No. 199555-1

**DX08**  
for DHR280, DHR282

Dust extraction system set  
Part No. 199579-7



**DHR282PT2J** **DHR282Z** 28mm (1-1/8")  
RM 3,818 RM 2,233

## Cordless Combination Hammer

Tukul Kombinasi Tanpa Kord

充电式冲击电钻电锤



- Auto-start Wireless System (AWS) connects to vacuum cleaner with Bluetooth

Standard Equipment: Side Grip, Depth Gauge, Cleaning Cloth, Bit Grease (194683-7)

• PT2J: 1x Two Port Multi Fast Charger, 2x 5.0Ah Battery, 1x Makpac Connector Box  
• Z: Without Charger, Battery & Carrying Case



<b>Impact Energy</b> Kekuatan Impak 单次最大锤击力	EPTA-Procedure 05/2009: 2.8J Our experimental conditions: 3.2J
<b>Capacity</b> Kapasiti 能力	Concrete: 28mm (1-1/8") Steel: 13mm (1/2")   Wood: 32mm (1-1/4")   Core Bit: 54mm (2-1/8")   Diamond Core Bit (Dry Type): 65mm (2-9/16")
<b>Impacts Per Minute (IPM)</b> Impak Per Minit 冲击数	0 - 5,000
<b>No Load Speed (RPM)</b> Kelajuan Tanpa Beban 回转数	0 - 980
<b>Chuck Capacity</b> Kapasiti Chuck 夹头能力	1.5 - 13mm (1/16 - 1/2")
<b>Max Output</b> Keluaran Maksima 最大输出	680W
<b>Dimensions (L x W x H)</b> Dimensi 体积	373x134x232mm (14-3/4"x5-1/4"x9-1/8")
<b>Net Weight</b> Berat Bersih 净重	3.9 - 5.0 kg (8.6 - 11.0 lbs.)
<b>Work Amount (approx.)</b> Jumlah Kerja 工作量	187 holes with BL1850B x2 Concrete Grade 40 D10.5mm x 60mm Depth

**DHR280PT2J** **DHR280Z** 28mm (1-1/8")  
RM 3,632 RM 2,045

## Cordless Combination Hammer

Tukul Kombinasi Tanpa Kord

充电式冲击电钻电锤



- High Power and Low Vibration

Standard Equipment: Side Grip, Depth Gauge, Cleaning Cloth, Bit Grease (194683-7)

• PT2J: 1x Two Port Multi Fast Charger, 2x 5.0Ah Battery, 1x Makpac Connector Box  
• Z: Without Charger, Battery & Carrying Case



<b>Impact Energy</b> Kekuatan Impak 单次最大锤击力	EPTA-Procedure 05/2009: 2.8J Our experimental conditions: 3.2J
<b>Capacity</b> Kapasiti 能力	Concrete: 28mm (1-1/8") Steel: 13mm (1/2")   Wood: 32mm (1-1/4")   Core Bit: 54mm (2-1/8")   Diamond Core Bit (Dry Type): 65mm (2-9/16")
<b>Impacts Per Minute (IPM)</b> Impak Per Minit 冲击数	0 - 5,000
<b>No Load Speed (RPM)</b> Kelajuan Tanpa Beban 回转数	0 - 980
<b>Chuck Capacity</b> Kapasiti Chuck 夹头能力	1.5 - 13mm (1/16 - 1/2")
<b>Max Output</b> Keluaran Maksima 最大输出	680W
<b>Dimensions (L x W x H)</b> Dimensi 体积	373x134x232mm (14-3/4"x5-1/4"x9-1/8")
<b>Net Weight</b> Berat Bersih 净重	3.9 - 4.9 kg (8.6 - 10.8 lbs.)
<b>Work Amount (approx.)</b> Jumlah Kerja 工作量	187 holes with BL1850B x2 Concrete Grade 40 D10.5mm x 60mm Depth

\* All list price shown are for reference only (exclude SST).

\* Semua harga yang ditunjukkan adalah untuk rujukan sahaja (tidak termasuk SST). 所有显示的建议零售价仅供参考 (不包括SST)。

Cordless  
Targeted Jobs

LED Flashlight  
Lampu Saku LED  
LED手电筒

Vacuum Cleaner  
Pembersih Vakuum  
吸尘器

Drilling / Fastening  
Gantut / Pasang  
钻孔 / 紧固

Impact Drilling / Demolition  
Gantut / Hancurkan  
冲击钻孔 / 拆除施工

Cutting  
Memotong  
切割

Grinding / Sanding  
Pengamiran / Pasah  
打磨 / 砂磨

Sawing  
Gajut  
锯切

Planing / Routing  
Pengayutan / Tumpang  
刨削 / 压花

Others  
Lain-lain  
其他

Outdoor Power Equipment  
Alatan Kerja Luar  
园机 / 户外

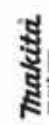



Li-ion Ah 6.0 5.0 4.0 3.0 2.0 1.5

**DHR263PM4** RM 4,042 | **DHR263RF4** RM 3,413 | **DHR263Z** 26mm (1") RM 1,798 442 mm

**Cordless Combination Hammer**

Tukul Kombinasi Tanpa Kord  
充电式冲击钻锤



- 3-Mode operation for Rotation Only, Hammering with Rotation or Hammering Only

**Standard Equipment:** Side Grip, Depth Gauge, Cleaning Cloth, Bit Grease (194683-7)

- PM4: 1x Two Port Multi Fast Charger, 4x 4.0Ah Battery, 1x Tool Bag
- RF4: 1x Rapid Charger, 4x 3.0Ah Battery, 1x Carrying Case
- Z: Without Charger, Battery & Carrying Case



**DDA460ZK** 13mm (1/2") RM 3,790

**Cordless Angle Drill**  
Gerudi Sudut Tanpa Kord  
充电式角向电钻



- Powerful drilling even large diameter holes

**Standard Equipment:** Chuck Key, Hex Wrench, Side Grip

- ZK: Without Charger & Battery

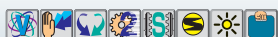

VIDEO CLIP  
Models and specs may vary by country

<b>Impact Energy</b> Kekuatan Impak 单次最大冲击力	EPTA-Procedure 05/2009: 2.5J Our experimental conditions: 3.0J
<b>Capacity</b> Kapasiti 能力	Concrete: 26mm (1")   Steel: 13mm (1/2")   Wood: 32 mm (1-1/4")
<b>Impacts Per Minute (IPM)</b> Impak Per Minit 冲击数	0 - 5,000
<b>No Load Speed (RPM)</b> Kelajuan Tanpa Beban 回转数	0 - 1,250
<b>Dimensions (L x W x H)</b> Dimensi 体积	350x116x232mm (13-3/4"x4-9/16"x9-1/8")
<b>Net Weight</b> Berat Bersih 净重	4.1 - 5.1kg (9.0 - 11.3lbs)
<b>Work Amount (approx.)</b> Jumlah Kerja 工作量	133 holes with BL1850B x2 Concrete Grade 40 D10.5mm x 60mm Depth

<b>Capacity</b> Kapasiti 能力	Steel: 13mm (1/2") Wood (Self-Feed Bit) Hi: 65mm (2-9/16") Wood (Self-Feed Bit) Lo: 118mm (4-5/8") Wood (Hole Saw) Hi: 105mm (4-1/8") Wood (Hole Saw) Lo: 159mm (6-1/4") Wood (Auger-Bit): 50mm (2")
<b>No Load Speed (RPM)</b> Kelajuan Tanpa Beban 回转数	High: 0 - 1,400   Low: 0 - 350

<b>Max Fastening Torque</b> Maksimum Tenaga Pemutaran Pengancing 最快扭力	High: 48N·m (430 in.lbs.) Low: 136N·m (1,210 in.lbs.)
--	--

<b>Max Output</b> Keluaran Maksima 最大输出	1,350 W
<b>Dimensions (L x W x H)</b> Dimensi 体积	538x128x223mm (21-1/4"x5"x8-3/4")
<b>Net Weight</b> Berat Bersih 净重	5.7 - 6.4kg (12.6 - 14.0lbs.)
<b>Work Amount (approx.)</b> Jumlah Kerja 工作量	80 holes with BL1850B x2 2 Layered SPF

# Cordless Shear Wrench

Perengkuh Ricih Tanpa Kord 充电式扭断套筒扳手

**Accessories (Optional)**

Aksesori 配件

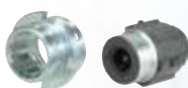

**Sleeve size reference table**

Pemilihan operasi 3-mod 3模式选择  
\*Type F (for HEXA TECH (GFD France)) \*\* for Chinese market

Bolt Size	Outer sleeve		Inner sleeve	
	L (mm)	Part No.	L (mm)	Part No.
M16	35	193804-8	36	195245-4
			36	*764421-7
M16	81	193807-2	82	193810-3
M16	100	764406-3	100	764400-5
M16	200	764407-1	200	764401-3
M20	37	193805-6	38	195217-9
M20	37	**196276-6		
M20	37	193805-6	38	*764422-5
M20	83	193806-4	84	193809-8
M20	100	764408-9	100	764402-1
M20	200	764409-7	200	764403-9

Bolt Size	Outer sleeve		Inner sleeve	
	L (mm)	Part No.	L (mm)	Part No.
M22, 7/8"	39	193960-4	39	195218-7
			39	*764423-3
M22, 7/8"	85	764364-3	85	764352-0
M22, 7/8"	100	764410-2	100	764404-7
M22, 7/8"	170	764365-1	170	764354-6
M22, 7/8"	200	764411-0	200	764405-5
5/8"	35	764362-7	36	764420-9
3/4"	37	764361-9	38	764419-4
3/4"	83	764363-5	84	764353-8
3/4"	168	764366-9	169	764355-4



**DWT310ZK** M20 (3/4"), M22 (7/8") RM 17,093

**Cordless Shear Wrench**  
Perengkuh Ricih Tanpa Kord  
充电式扭断套筒扳手



- Up to 14% Faster Fastening than Corded Model 6922NB

**Standard Equipment:** Screwdriver, Shoulder Belt, M20 Sleeve, M22 Sleeve

- ZK: Without Charger & Battery



<b>Capacity</b> Kapasiti 能力	High Strength Torque Shear Bolt (HTB): M16 (optional), M20, M22 (5/8", 3/4", 7/8") Super High Strength Torque Shear Bolt (SHTB): M16, M20 (5/8", 3/4")
<b>No Load Speed (RPM)</b> Kelajuan Tanpa Beban 回转数	14
<b>Max Fastening Torque</b> Maksimum Tenaga Pemutaran Pengancing 最快扭力	804N·m (593ft.lbs.)
<b>Dimensions (L x W x H)</b> Dimensi 体积	296x130x377mm (11-5/8"x5-1/8"x14-7/8")
<b>Net Weight</b> Berat Bersih 净重	6.5 - 7.1kg (14.3 - 15.7lbs.)
<b>Work Amount (approx.)</b> Jumlah Kerja 工作量	300 pcs with BL1850B x2 M22 (7/8") Torque Shear Bolts

\* All list price shown are for reference only (exclude SST).

\* Semua harga yang ditunjukkan adalah untuk rujukan sahaja (tidak termasuk SST). 所有显示的建议零售价仅供参考 (不包括SST)。

Cordless Target Kord 无绳  
LED Flashlight Lampu Suluh LED LED照明灯  
Vacuum Cleaner Pemilauhi Vakuüm 吸尘器  
Drilling / Fastening Gerudi / Pengikat 钻孔 / 紧固  
Impact Drilling / Demolition Gerudi / Penanggal 冲击钻孔 / 拆除加工  
Cutting Pemotong 切割  
Grinding / Sanding Pengisar / Pichin 研磨 / 打磨  
Sawing Cergas 锯切  
Planing / Routing Pengisar / Tangkang 刨削 / 雕刻  
Others Lain-lain 其他  
Outdoor Power Equipment Alatan Kerja Luar 户外户外





Li-ion Ah 6.0 5.0 4.0 3.0 2.0 1.5



# Cordless Angle Grinder

Pengisar Sudut Tanpa Kord 充电式角向磨光机

## DGA701Z 180mm (7")

RM 1,795

**Cordless Angle Grinder**  
Pengisar Sudut Tanpa Kord  
充电式角向磨光机



- Auto-start Wireless System (AWS) connects to vacuum cleaner with Bluetooth



Standard Equipment: Wheel Cover, Side Grip, Lock Nut Wrench

• Z: Without Charger & Battery



<b>Wheel Diameter</b> Diameter Mata Canai 砂轮片直径	180mm (7")
<b>Hole Diameter</b> Diameter Lubang 孔直径	22.23mm (7/8")
<b>Max Wheel Thickness</b> Ketebalan Roda 轮片厚度	7.2 mm (1/4")
<b>No Load Speed (RPM)</b> Kelajuan Tanpa Beban 回转数	7,800
<b>Max Output</b> Keluasan Maksima 最大输出	1,500W
<b>Dimensions (L x W x H)</b> Dimensi 体积	499x200x158mm (19-5/8"x7-7/8"x6-1/4")
<b>Net Weight</b> Berat Bersih 净重	5.0 - 6.0kg (11.0 - 13.3lbs.)
<b>Work Amount (approx.)</b> Jumlah Kerja 工作量	17 cuts with BL1850B x2 Equiangular Angle Steel 50 x 50mm

## DGA700Z 180mm (7")

RM 1,605

**Cordless Angle Grinder**  
Pengisar Sudut Tanpa Kord  
充电式角向磨光机



- Electric brake stops the grinding wheel in 4.5 seconds or less for increased operator safety



Standard Equipment: Wheel Cover, Side Grip, Lock Nut Wrench

• Z: Without Charger & Battery



<b>Wheel Diameter</b> Diameter Mata Canai 砂轮片直径	180mm (7")
<b>No Load Speed (RPM)</b> Kelajuan Tanpa Beban 回转数	7,800
<b>Dimensions (L x W x H)</b> Dimensi 体积	499x200x158mm (19-5/8"x7-7/8"x6-1/4")
<b>Net Weight</b> Berat Bersih 净重	5.0 - 6.0kg (11.02 - 13.23lbs)
<b>Work Amount (approx.)</b> Jumlah Kerja 工作量	17 cuts with BL1850B x2 Equiangular Angle Steel 50 x 50mm

## DGA901Z 230mm (9")

RM 1,810

**Cordless Angle Grinder**  
Pengisar Sudut Tanpa Kord  
充电式角向磨光机



- Auto-start Wireless System (AWS) connects to vacuum cleaner with Bluetooth



Standard Equipment: Wheel Cover, Side Grip, Lock Nut Wrench

• Z: Without Charger & Battery



<b>Wheel Diameter</b> Diameter Mata Canai 砂轮片直径	230mm (9")
<b>Hole Diameter</b> Diameter Lubang 孔直径	22.23mm (7/8")
<b>Max Wheel Thickness</b> Ketebalan Roda 轮片厚度	6.5mm (1/4")
<b>No Load Speed (RPM)</b> Kelajuan Tanpa Beban 回转数	6,000
<b>Max Output</b> Keluasan Maksima 最大输出	1,500W
<b>Dimensions (L x W x H)</b> Dimensi 体积	499x250x158mm (19-5/8"x9-7/8"x6-1/4")
<b>Net Weight</b> Berat Bersih 净重	5.2 - 8.0kg (11.46 - 17.64lbs.)
<b>Work Amount (approx.)</b> Jumlah Kerja 工作量	17 cuts with BL1850B x2 Equiangular Angle Steel 50 x 50mm

## DGA900Z 230mm (9")

RM 1,623

**Cordless Angle Grinder**  
Pengisar Sudut Tanpa Kord  
充电式角向磨光机



- Electric brake stops the grinding wheel in 4.5 seconds or less for increased operator safety



Standard Equipment: Wheel Cover, Side Grip, Lock Nut Wrench

• Z: Without Charger & Battery



<b>Wheel Diameter</b> Diameter Mata Canai 砂轮片直径	230mm (9")
<b>No Load Speed (RPM)</b> Kelajuan Tanpa Beban 回转数	6,000
<b>Dimensions (L x W x H)</b> Dimensi 体积	499x250x158mm (19-5/8"x9-7/8"x6-1/4")
<b>Net Weight</b> Berat Bersih 净重	5.2 - 8.0kg (11.46 - 17.64lbs)
<b>Work Amount (approx.)</b> Jumlah Kerja 工作量	17 cuts with BL1850B x2 Equiangular Angle Steel 50 x 50mm

\* All list price shown are for reference only (exclude SST).

\* Semua harga yang ditunjukkan adalah untuk rujukan sahaja (tidak termasuk SST). 所有显示的建议零售价仅供参考 (不包括SST)。

Cordless  
Tanpa Kord 充电式

LED Flashlight  
Lampu Suluh LED  
LED 手电筒

Vacuum Cleaner  
Pembersih Vakuum  
吸尘器

Drilling / Fastening  
Gantut / Pengikat  
钻孔 / 紧固

Impact Drilling / Demolition  
Gantut / Penebuk  
冲击钻孔 / 拆毁施工

Cutting  
Penerajang  
切割

Grinding / Sanding  
Pengisar / Penech  
研磨 / 砂磨

Sawing  
Gergaji  
锯切

Planing / Routing  
Pengaliran / Tanggapan  
刨削 / 铣削

Others  
Lain-lain  
其他

Outdoor Power Equipment  
Alatan Kuat Luar  
户外动力设备

Thakita  
TENT



Li-ion Ah 6.0 5.0 4.0 3.0 2.0 1.5

**DSP601Z** **DSP600Z** 165mm (6-1/2")  
RM 3,273 RM 2,678

**Cordless Plunge Cut Saw**  
Pensidar Sudut Tanpa Kord  
充电式角向磨光机



- Auto-start Wireless System (AWS) connects to vacuum cleaner with Bluetooth



Standard Equipment: TCT Saw Blade (B-57364), Hex Wrench

- Z: Without Charger & Battery

ONLY FOR DSP601



<b>Blade Diameter</b> Diameter Bilah 锯片直径	165mm (6-1/2")
<b>Bevel Capacity</b> Kapasiti Bevel 斜角容量	-1° - 48°
<b>Max Cutting Capacity</b> Kapasiti Pemotongan Maksimum 最大切割能力	90°: 56mm (2-3/16") 45°: 40 mm (1-9/16") 48°: 38 mm (1-1/2")
<b>No Load Speed (RPM)</b> Kelajuan Tanpa Beban 回转速数	2,500 - 6,300
<b>Dimensions (L x W x H)</b> Dimensi 体积	346x241x272mm (13-5/8"x9-1/2"x10-3/4")
<b>Net Weight</b> Berat Bersih 淨重	4.4 - 5.1kg (9.8 - 11.2lbs.)
<b>Work Amount (approx.)</b> Jumlah Kerja 工作量	48 cuts with BL1850B x2 Melamine Board 32mm (Thick) x 1000mm (Length)

## Cordless Slide Compound Miter Saw

Gergaji Kompaun Miter Tanpa Kord 充电式斜断锯



**DLS211Z** 305mm (12")  
RM 6,132

**Cordless Slide Compound Miter Saw**  
Gergaji Kompaun Miter Tanpa Kord  
充电式斜断锯



- Auto-start Wireless System (AWS) connects to vacuum cleaner with Bluetooth



Standard Equipment: TCT Saw Blade (B-67452), Dust Bag (1228520), Triangular Rule, Vertical Vise, Hex Wrench

- Z: Without Charger & Battery



<b>Blade Diameter</b> Diameter Bilah 锯片直径	305mm (12")
<b>Miter Angle</b> Sudut Miter 斜接角	60°L / 60°R
<b>Bevel Angle</b> Sudut Bevel 斜角	48°L / 48°R
<b>Max Cutting Capacity</b> Kapasiti Pemotongan Maksimum 最大切割能力	90° Miter: 107 x 363mm (4-1/4" x 14-1/4") 90° Miter: 92 x 382mm (3-5/8" x 15") 45° Miter, L/R: 107 x 255mm (4-1/4" x 10") 45° Miter, L/R: 92 x 268mm (3-5/8" x 10-1/2")
<b>No Load Speed (RPM)</b> Kelajuan Tanpa Beban 回转速数	4,400
<b>Dimensions (L x W x H)</b> Dimensi 体积	898x690x725mm (35-1/4"x27-1/4"x28-1/2")
<b>Net Weight</b> Berat Bersih 淨重	30.7 - 31.3kg (67.6 - 69.1lbs.)

**DLS111Z** 260mm (10-1/4")  
RM 5,353

**Cordless Slide Compound Miter Saw**  
Gergaji Kompaun Miter Tanpa Kord  
充电式斜断锯



- Auto-start Wireless System (AWS) connects to vacuum cleaner with Bluetooth



Standard Equipment: TCT Saw Blade (B-64668), Dust Bag (1228520), Triangular Rule, Vertical Vise, Hex Wrench

- Z: Without Charger & Battery



<b>Blade Diameter</b> Diameter Bilah 锯片直径	260mm (10-1/4")
<b>Miter Angle</b> Sudut Miter 斜接角	60°L / 60°R
<b>Bevel Angle</b> Sudut Bevel 斜角	48°L / 48°R
<b>Max Cutting Capacity</b> Kapasiti Pemotongan Maksimum 最大切割能力	90° Miter: 91 x 279mm (3-5/8" x 11") 90° Miter: 68 x 310mm (2-11/16" x 12-1/4") 45° Miter, L/R: 91 x 197mm (3-5/8" x 7-3/4") 45° Miter, L/R: 68 x 218mm (2-11/16" x 8-5/8")
<b>No Load Speed (RPM)</b> Kelajuan Tanpa Beban 回转速数	4,400
<b>Dimensions (L x W x H)</b> Dimensi 体积	805x644x660mm (31-3/4"x25-3/8"x26")
<b>Net Weight</b> Berat Bersih 淨重	26.6 - 27.3kg (58.6 - 60.2 lbs.)

**DLS714PM2** **DLS714Z** 190mm (7-1/2")  
RM 5,813 RM 4,373

**Cordless Slide Compound Miter Saw**  
Gergaji Kompaun Miter Tanpa Kord  
充电式斜断锯



- Large cutting capacity; Crosscuts up to 52 x 300 mm (2-1/16" x 11-3/4") at 90°



Standard Equipment: TCT Saw Blade (B-03850), Dust Bag (1228520), Holder Set, Vertical Vise, Hex Wrench, Triangular Rule

- PM2: 1x Two Port Multi Fast Charger, 2x 4.0Ah Battery
- Z: Without Charger & Battery



<b>Blade Diameter</b> Diameter Bilah 锯片直径	190mm (7-1/2")
<b>Miter Angle</b> Sudut Miter 斜接角	47°L / 57°R
<b>Bevel Angle</b> Sudut Bevel 斜角	45°L / 5°R
<b>Max Cutting Capacity</b> Kapasiti Pemotongan Maksimum 最大切割能力	90°: 52 x 300mm (2-1/16" x 11-3/4") at 45° left: 40 x 300mm (1-9/16" x 11-3/4") at 5° right: 40 x 300mm (1-9/16" x 11-3/4")
<b>No Load Speed (RPM)</b> Kelajuan Tanpa Beban 回转速数	5,700
<b>Dimensions (L x W x H)</b> Dimensi 体积	655x430x445mm (25-3/4"x17"x17-1/2")
<b>Net Weight</b> Berat Bersih 淨重	12.6kg (27.8lbs)
<b>Work Amount (approx.)</b> Jumlah Kerja 工作量	350 pcs with BL1850B x2 SPF Material 2x4"

\* All list price shown are for reference only (exclude SST).

\* Semua harga yang ditunjukkan adalah untuk rujukan sahaja (tidak termasuk SST). 所有显示的建议零售价仅供参考 (不包括SST)。

Cordless  
Target Kord 无绳式

LED Flashlight  
Lampu Suluh LED  
LED 照明灯

Vacuum Cleaner  
Pembersih Vakuam  
吸尘器

Drilling / Fastening  
Ganda / Pengikat  
钻孔 / 紧固

Impact Drilling / Demolition  
Ganda / Penembak  
冲击钻孔 / 拆除加工

Cutting  
Pemotong  
切割

Grinding / Sanding  
Pengisar / Piskin  
磨削 / 砂磨

Sawing  
Gergaji  
锯切

Planing / Routing  
Pengisar / Tangkapan  
刨削 / 雕刻

Others  
Lain-lain  
其他

Outdoor Power Equipment  
Alatan Kerja Luar  
园具-户外

Makita  
MAKITA



Li-ion Ah 6.0 5.0 4.0 3.0 2.0 1.5

**DJR360RF4 DJR360Z**  
RM 3,382 RM 1,768

**Cordless Recipro Saw**  
Gergaji Resipro Tanpa Kord  
充电式往复锯



- Electric 2 speed provides ideal RPM of high speed for wooden cutting and low speed for metal cutting

Standard Equipment: Recipro Saw Blades 2pcs (B-05175 & B-05169)

- RF4: 1x Rapid Charger, 4x 3.0Ah Battery
- Z: Without Charger, Battery & Carrying Case

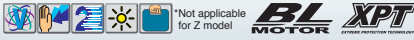

<b>Length of Stroke</b> Panjang Strok 冲程长度	32mm (1-1/4")
<b>Strokes Per Minute (SPM)</b> Kelajuan Strok 冲程速度	High: 0 - 3,000   Low: 0 - 2,300
<b>Capacity</b> Kapasiti 能力	Pipe: 130mm (5-1/8") Wood: 255mm (10")
<b>Dimensions (L x W x H)</b> Dimensi 体积	449x116x243mm (17-3/4"x4-9/16"x9-9/16")
<b>Net Weight</b> Berat Bersih 淨重	4.0 - 4.7kg (8.9 - 10.3lbs)
<b>Work Amount (approx.)</b> Jumlah Kerja 工作量	110 pcs with BL1850B x2 Steel Pipe (φ34 x 3mm)

# Cordless Portable Cut-off

Mesin Pemotong Tanpa Kord 充电式无刷轻钢架砂轮切断机

## CUTTING CAPACITY

A workpiece thinner than 1.6mm is recommended for cutting with this tool

Form of Materials	Diagram	Diagram	Diagram	Diagram
<b>Miter Angle 0°</b>	D: ø127mm (5")	H x W: 115 x 130 (4-1/2"x5-1/8") 102 x 194mm (4"x 7-5/8") 70 x 233mm (2-3/4"x 9-1/8")	H x W: 119 x 119mm (4-11/16"x 4-11/16")	S x S: 137 x 137mm (5-3/8"x 5-3/8")
<b>Miter Angle 45°</b>	D: ø127mm (5")	H x W: 115 x 103mm (4-1/2"x 4-1/16")	H x W: 106 x 106mm (4-3/16"x 4-3/16")	S x S: 100 x 100mm (4"x 4")

D: Diameter | W: Width | H: Height | S: Side

**DLW140Z** 355mm (14")  
RM 2,423

**Cordless Portable Cut-off**  
Mesin Pemotong Tanpa Kord  
充电式无刷轻钢架砂轮切断机



- World's First Cordless Portable Cut-off

Standard Equipment:  
Cut-Off Wheel (B-64696)

- Z: Without Charger & Battery



DLW140

VIDEO CLIP

Models and specs may vary by country

<b>Wheel Diameter</b> Diameter Mata Canai 砂轮片直径	355mm (14")
<b>Hole Diameter</b> Diameter Lubang 孔直径	25.4mm (1")
<b>Max Wheel Thickness</b> Ketebalan Roda 轮片厚度	3mm (1/8")
<b>No Load Speed (RPM)</b> Kelajuan Tanpa Beban 回转数	3,800
<b>Capacity at 90°</b> Kapasiti Pemotongan 切割能力	Round: 127mm (5") Rectangular: 115x130mm (4-1/2"x5-1/8") Rectangular: 102x194mm (4"x7-5/8") Rectangular: 70x233mm (2-3/4"x9-1/8")
<b>Capacity at 45°</b> Kapasiti Pemotongan 切割能力	Round: 127mm (5") Rectangular: 115x103mm (4-1/2"x4-1/16")
<b>Dimensions (L x W x H)</b> Dimensi 体积	537x280x640mm (21-1/8"x11"x25-1/4")
<b>Net Weight</b> Berat Bersih 淨重	17.2 - 17.8kg (37.9 - 39.3lbs.)
<b>Work Amount (approx.)</b> Jumlah Kerja 工作量	130 cuts with BL1850B x2 Metal Stud (H:75mm, W: 45mm, T: 0.8mm)

**DRS780Z** 185mm (7-1/4")  
RM 1,905

**Cordless Rear Handle Saw**  
Gergaji Piring Tanpa Kord  
充电式后把手圆锯



- Cuts 3X Material in a Single Pass;  
Blade Left Design

Standard Equipment: TCT Saw Blade (B-62022), Offset Wrench

- Z: Without Charger & Battery



<b>Blade Diameter</b> Diameter Bilah 锯片直径	185mm (7-1/4")
<b>Max Cutting Capacity</b> Kapasiti Pemotongan Maksimum 最大切割能力	90°: 65mm (2-9/16") 45°: 45mm (1-3/4") 53°: 38mm (1-1/2")
<b>No Load Speed (RPM)</b> Kelajuan Tanpa Beban 回转数	5,100
<b>Dimensions (L x W x H)</b> Dimensi 体积	446x196x270mm (17-1/2"x7-3/4"x10-5/8")
<b>Net Weight</b> Berat Bersih 淨重	5.0 - 5.6kg (11.1 - 12.4lbs.)

**DHS710RM2J DHS710RF2J** 190mm (7-1/2")  
RM 2,568 RM 2,405

**Cordless Circular Saw**  
Gergaji Piring Tanpa Kord  
充电式圆锯



- Lightweight for operator comfort

Standard Equipment: TCT Saw Blade (D-09123), Rip Fence (Guide Rule), Hex Wrench

- RM2J: 1x Rapid Charger, 2x 4.0Ah Battery, 1x Makpac Connector Box
- RF2J: 1x Rapid Charger, 2x 3.0Ah Battery, 1x Makpac Connector Box



DHS710

VIDEO CLIP

Models and specs may vary by country

<b>Blade Diameter</b> Diameter Bilah 锯片直径	190/185mm (7-1/2"/7-1/4")
<b>Max Cutting Capacity</b> Kapasiti Pemotongan Maksimum 最大切割能力	90°: 68.5/66mm (2-11/16"/2-5/8") 45°: 49/47.5mm (1-15/16"/1-7/8") 50°: 44/42.5mm (1-3/4"/1-11/16")
<b>No Load Speed (RPM)</b> Kelajuan Tanpa Beban 回转数	4,800
<b>Dimensions (L x W x H)</b> Dimensi 体积	356x217x298mm (14"x8-1/2"x11-3/4")
<b>Net Weight</b> Berat Bersih 淨重	3.9 - 4.6kg (8.6 - 10.1lbs)
<b>Work Amount (approx.)</b> Jumlah Kerja 工作量	205 pcs with BL1850B x2 SPF 2 x 10 (thickness 38mm, width 235mm), 90° cut

\* All list price shown are for reference only (exclude SST).

\* Semua harga yang ditunjukkan adalah untuk rujukan sahaja (tidak termasuk SST). 所有显示的建议零售价仅供参考 (不包括SST)。

Cordless  
Target Model 36V

LED Flashlight  
Lampu Saku LED  
LED手电筒

Vacuum Cleaner  
Pembersih Vakuum  
吸尘器

Drilling / Fastening  
Gergaji / Pengikat  
钻孔 / 紧固

Impact Drilling / Demolition  
Gergaji / Pemusnah  
冲击钻孔 / 拆除施工

Cutting  
Pemotong  
切割

Grinding / Sanding  
Pengkilan / Poles  
打磨 / 砂磨

Sawing  
Gergaji  
锯切

Planing / Routing  
Pengkilan / Tangkapan  
刨平 / 雕刻

Others  
Lain-lain  
其他

Outdoor Power Equipment  
Alatan Kerja Luar  
园机/户外





Li-ion Ah 6.0 | 5.0 | 4.0 | 3.0 | 2.0 | 1.5

# Cordless Circular Saw

Gergaji Piring Tanpa Kord 充电式圆锯

Light weight

Ringan 轻量

**6.0kg**

with BL1860B x2  
6.0Ah Battery

### Variable speed control by dial

Kawalan kelajuan berubah dengan dial 拨盘变速控制



Battery capacity warning lamp

### Blower function

Fungsi Peniup 吹风功能



### Twin LED Job light

Lampu kerja LED LED工作灯



### Bevel cuts up to 1° left and 60° right

Potongan serong 1° kiri dan 60° kanan  
斜切左 1° / 右 60°

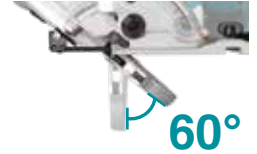

**DHS900PT2** | **DHS900Z** 235mm (9-1/4")  
RM 5,645 | RM 4,060

**Cordless Circular Saw**  
Gergaji Piring Tanpa Kord  
充电式圆锯



- Auto-start Wireless System (AWS) connects to vacuum cleaner with Bluetooth

Standard Equipment: TCT Saw Blade (E-01959), Sub Base, Hex Wrench

- PT2: 1x Two Port Multi Fast Charger, 2x 5.0Ah Battery
- Z: Without Charger, Battery & Carrying Case



**DHS782Z** 190mm (7-1/2") / 185mm (7-1/4")  
RM 2,943

**Cordless Circular Saw**  
Gergaji Piring Tanpa Kord  
充电式圆锯



- Overload alert using ADT lamp

Standard Equipment: TCT Saw Blade, Dust Nozzle, Hex Wrench, Guide Rule

- Z: Without Charger & Battery



**DHS783Z** 190mm (7-1/2") / 185mm (7-1/4")  
RM 3,228

**Cordless Circular Saw**  
Gergaji Piring Tanpa Kord  
充电式圆锯



- Auto-start Wireless System (AWS) connects to vacuum cleaner with Bluetooth

Standard Equipment: TCT Saw Blade (B-62022), Hex Wrench, Guide Rule, Dust Nozzle

- Z: Without Charger & Battery



<b>Blade Diameter</b> Diameter Bilah 锯片直径	235mm (9-1/4")
<b>Hole Diameter</b> Diameter Lubang 孔直径	15.88mm (5/8")   25mm (1")   25.4mm (1")   30mm (1-3/16")
<b>Max Cutting Capacity</b> Kapasiti Pemotongan Maksimum 最大切割能力	90°: 85mm (3-3/8") 45°: 61mm (2-3/8") 60°: 44mm (1-3/4")
<b>No Load Speed (RPM)</b> Kelajuan Tanpa Beban 回转数	4,500
<b>Dimensions (L x W x H)</b> Dimensi 体积	413x196x316mm (16-1/4"x7-3/4"x12-1/2")
<b>Net Weight</b> Berat Bersih 净重	5.3 - 6.0kg (11.7 - 13.2lbs.)

<b>Blade Diameter</b> Diameter Bilah 锯片直径	190mm (7 - 1/2")   185mm (7 - 1/4")
<b>Hole Diameter</b> Diameter Lubang 孔直径	15.88mm (5/8")   20mm (13/16")   30mm (1-3/16")
<b>Max Cutting Capacity</b> Kapasiti Pemotongan Maksimum 最大切割能力	90°: 62.5/ 60mm (2-7/16"/ 2-3/8") 45°: 44.5/ 43mm (1-3/4"/ 1-11/16") 48°: 42/ 41mm (1-5/8"/ 1-5/8")
<b>No Load Speed (RPM)</b> Kelajuan Tanpa Beban 回转数	6,000
<b>Max Output</b> Keluaran Maksima 最大输出	1,800W
<b>Dimensions (L x W x H)</b> Dimensi 体积	348x210x290mm (13-3/4"x8-1/4"x11-3/8")
<b>Net Weight</b> Berat Bersih 净重	4.5 - 5.1kg (9.9 - 11.3lbs.)

<b>Blade Diameter</b> Diameter Bilah 锯片直径	190mm (7 - 1/2")   185mm (7 - 1/4")
<b>Hole Diameter</b> Diameter Lubang 孔直径	15.88mm (5/8")   20mm (13/16")   30mm (1-3/16")
<b>Max Cutting Capacity</b> Kapasiti Pemotongan Maksimum 最大切割能力	90°: 62.5/ 60mm (2-7/16"/ 2-3/8") 45°: 44.5/ 43mm (1-3/4"/ 1-11/16") 48°: 42/ 41mm (1-5/8"/ 1-5/8")
<b>No Load Speed (RPM)</b> Kelajuan Tanpa Beban 回转数	6,000
<b>Max Output</b> Keluaran Maksima 最大输出	1,800W
<b>Dimensions (L x W x H)</b> Dimensi 体积	348x210x290mm (13-3/4"x8-1/4"x11-3/8")
<b>Net Weight</b> Berat Bersih 净重	4.5 - 5.1kg (9.9 - 11.3lbs.)

\* All list price shown are for reference only (exclude SST).

\* Semua harga yang ditunjukkan adalah untuk rujukan sahaja (tidak termasuk SST). 所有显示的建议零售价仅供参考 (不包括SST)。

Cordless  
Target Kord 无绳式

LED Flashlight  
Lampu Suluh LED  
LED照明灯

Vacuum Cleaner  
Pembersih VAKUUM  
吸尘器

Drilling / Fastening  
Draut / Pasang  
钻孔 / 紧固

Impact Drilling / Demolition  
Draut / Penembak  
起工钻孔 / 拆墙加工

Cutting  
Pemotong  
切割

Grinding / Sanding  
Pengamir / Pasuk  
磨削 / 砂磨

Sawing  
Gergaji  
锯切

Planing / Routing  
Pengamir / Tangkap  
刨削 / 雕刻

Others  
Lain-lain  
其他

Outdoor Power Equipment  
Alatan Kerja Luar  
园具-户外





Li-ion Ah 6.0 | 5.0 | 4.0 | 3.0 | 2.0 | 1.5

# Battery Powered Grass Trimmer

Pemotong Rumput Berkuasa Bateri 充电式割草机

## "Simple" Portable Power Supply Unit powered by multiple LXT batteries

Unit Bekalan Kuasa Mudah Alih "Mudah" yang dikuasakan oleh pelbagai bateri LXT  
由多个LXT电池供电的“简单”便携式电源设备



UR201C

PDC01

### TWO VARIATIONS



(Without Battery)

18Vx2 Adapter only Part No.191A67-6

(Without Battery)

18V & 18Vx2 Adapter Part No.191A62-6

### UR201CZ

Price TBA

**Battery Powered Grass Trimmer**  
Pemotong Rumput Berkuasa Bateri  
充电式割草机



- 1.0kW max output power similar to 30mL class engine grass trimmers

**Standard Equipment:** Safety Goggles, Metal Blade, Nylon Cutting Head, Plastic Blade, Blade Cover (for metal blade), Accessory Bag, Hex Wrench, Box Wrench, Band Assembly

• Z: Without Charger & Battery



<b>Cutting Width</b> Lebar Keratan 切割宽度	<b>Metal Blade:</b> 255mm (10") <b>Nylon Cutting Head:</b> 430mm (17") <b>Plastic Blade:</b> 305 mm (12")
--	---

<b>No Load Speed (RPM)</b> Kelajuan Tanpa Beban 回转数	<b>Metal Blade (3/2/1):</b> 0 - 7,000 / 0 - 5,500 / 0 - 4,600 <b>Nylon Cutting Head (3/2/1):</b> 0 - 5,500 / 0 - 5,000 / 0 - 4,600 <b>Plastic Blade (305mm) (3/2/1):</b> 0 - 7,000 / 0 - 5,500 / 0 - 4,600 <b>Plastic Blade (255mm) (3/2/1):</b> 0 - 5,500 / 0 - 5,000 / 0 - 4,600
--	---

<b>Spindle Size</b> Saiz Spindel 主轴尺寸	M10 x 1.25LH
--	--------------

<b>Dimensions (L x W x H)</b> Dimensi 体积	1,795x400x269mm (70-1/2"x15-3/4"x10-5/8")
---	--

<b>Net Weight</b> Berat Bersih 净重	4.7kg (10.4lbs.)
--------------------------------------	------------------

### DUR369LZ

Price TBA

**Cordless Grass Trimmer**  
Pemotong Rumput Tanpa Kord  
充电式割草机

- 1.0kW max output power similar to 30mL class engine grass trimmers

**Standard Equipment:** Safety Goggles, Metal Blade / Nylon Cutting Head / Plastic Blade (country-specific), Blade cover (for the product with metal blade), Accessory Bag, Hex Wrench, Box Wrench, Shoulder Belt

• Z: Without Charger & Battery



<b>Cutting Width</b> Lebar Keratan 切割宽度	<b>Metal Blade:</b> 255mm (10") <b>Nylon Cutting Head:</b> 430mm (17") <b>Plastic Blade:</b> 305 mm (12")
--	---

<b>No Load Speed (RPM)</b> Kelajuan Tanpa Beban 回转数	<b>Metal Blade (3/2/1):</b> 0 - 7,000 / 0 - 5,500 / 0 - 4,600 <b>Nylon Cutting Head (3/2/1):</b> 0 - 5,500 / 0 - 5,000 / 0 - 4,600 <b>Plastic Blade (305 mm) (3/2/1):</b> 0 - 7,000 / 0 - 5,500 / 0 - 4,600 <b>Plastic Blade (255 mm) (3/2/1):</b> 0 - 5,500 / 0 - 5,000 / 0 - 4,600
--	---

<b>Spindle Size</b> Saiz Spindel 主轴尺寸	M10 x 1.25LH
--	--------------

<b>Dimensions (L x W x H)</b> Dimensi 体积	1,846x400x269mm (72-1/2"x15-3/4"x10-5/8")
---	--

<b>Net Weight</b> Berat Bersih 净重	5.7 - 6.3kg (12.6 - 13.9lbs.)
--------------------------------------	-------------------------------

### DUR364LPM4

RM 4,118

### DUR364LRM2

RM 3,015

### DUR364LZ

RM 1,877

**Cordless Grass Trimmer**  
Pemotong Rumput Tanpa Kord  
充电式割草机



- 2-Speed options allows the operator to match speed to application

**Standard Equipment:** Safety Goggles (195246-2), Nylon Cutting Head, Accessory Bag, Hex Wrench

- PM4: 1x Two Port Multi Fast Charger, 4x 4.0Ah Battery
- RM2: 1x Rapid Charger, 2x 4.0Ah Battery
- Z: Without Charger & Battery



<b>Cutting Width</b> Lebar Keratan 切割宽度	<b>Trimmer Head:</b> 350mm (13-3/4") <b>Plastic Blade:</b> 255mm (10")
--	---

<b>No Load Speed (RPM)</b> Kelajuan Tanpa Beban 回转数	<b>High:</b> 6,500   <b>Low:</b> 5,000
--	--

<b>Spindle Size</b> Saiz Spindel 主轴尺寸	M8 x 1.25RH
--	-------------

<b>Dimensions (L x W x H)</b> Dimensi 体积	1,754x310x229mm (69"x12-1/4"x9")
---	-------------------------------------

<b>Net Weight</b> Keberatan 净重	3.6 - 4.4kg (8.0 - 9.7lbs)
-----------------------------------	----------------------------

<b>Continuous Usage Time (approx.)</b> Masa Penggunaan Berterusan 连续使用时间	<b>Low:</b> 490min   <b>Mid:</b> 221min   <b>High:</b> 149min with BL1850B x2
---	---

\* All list price shown are for reference only (exclude SST).

\* Semua harga yang ditunjukkan adalah untuk rujukan sahaja (tidak termasuk SST). 所有显示的建议零售价仅供参考 (不包括SST)。

Cordless  
Tanpa Kord / 充电式

LED Flashlight  
Lampu Suhu LED  
LED 手电筒

Vacuum Cleaner  
Pembersih Vakuum  
吸尘器

Drilling / Fastening  
Gergaji / Pengikat  
电钻 / 紧固件

Impact Drilling / Demolition  
Gergaji / Pemusnah  
冲击电钻 / 破拆工具

Cutting / Pruning  
Pemotong / Potong  
修剪 / 修剪

Grinding / Sanding  
Pengisar / Poles  
打磨 / 打磨

Sawing  
Gergaji  
锯切

Planing / Routing  
Pengisar / Tanggapan  
刨平 / 刨平

Others  
Lain-lain  
其他

Outdoor Power Equipment  
Alatan Kuasa Luar  
户外动力设备

Makita  
Makita

Makita  
Makita



Li-ion Ah 6.0 5.0 4.0 3.0 2.0 1.5

**DUR368APT2 | DUR368AZ**  
RM 4,513 | RM 2,927

**Cordless Grass Trimmer**  
Pemotong Rumput Tanpa Kord  
充电式割草机



- Lightweight for reduced operator fatigue

**Standard Equipment:** Safety Goggles (195246-2), Plastic Blade, Accessory Bag, Hex Wrench, Band Assembly

- PT2: 1x Two Port Multi Fast Charger, 2x 5.0Ah Battery
- Z: Without Charger & Battery



<b>Cutting Width</b> Lebar Keratan 切割宽度	<b>Metal Blade: 255mm (10")</b> <b>Trimmer Head: 350mm (13-3/4")</b> <b>Plastic Blade: 255mm (10")</b>
<b>No Load Speed (RPM)</b> Kelajuan Tanpa Beban 回转数	<b>High: 6,500   Med: 5,300   Low: 3,500</b>
<b>Spindle Size</b> Saiz Spindel 主轴尺寸	<b>M10 x 1.25LH</b>
<b>Dimensions (L x W x H)</b> Dimensi 体积	<b>1,758x615x442mm (69-1/4"x24-1/4"x17-3/8")</b>
<b>Net Weight</b> Berat Bersih 净重	<b>4.1 - 4.7kg (9.0 - 10.5lbs.)</b>
<b>Continuous Usage Time (approx.)</b> Masa Penggunaan Berterusan 连续使用时间	<b>104min Low Speed with BL1850B x2</b>

**DUR368LPT2 | DUR368LZ**  
RM 4,190 | RM 2,605

**Cordless Grass Trimmer**  
Pemotong Rumput Tanpa Kord  
充电式割草机

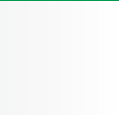

- Lightweight for reduced operator fatigue

**Standard Equipment:** Safety Goggles (195246-2), Plastic Blade, Accessory Bag, Hex Wrench, Band Assembly

- PT2: 1x Two Port Multi Fast Charger, 2x 5.0Ah Battery
- Z: Without Charger & Battery



<b>Cutting Width</b> Lebar Keratan 切割宽度	<b>Metal Blade: 255mm (10")</b> <b>Trimmer Head: 350mm (13-3/4")</b> <b>Plastic Blade: 255mm (10")</b>
<b>No Load Speed (RPM)</b> Kelajuan Tanpa Beban 回转数	<b>High: 6,500   Med: 5,300   Low: 3,500</b>
<b>Spindle Size</b> Saiz Spindel 主轴尺寸	<b>M10 x 1.25LH</b>
<b>Dimensions (L x W x H)</b> Dimensi 体积	<b>1,758x362x231mm (69-1/4"x14-1/4"x9-1/8")</b>
<b>Net Weight</b> Berat Bersih 净重	<b>3.9 - 4.5kg (8.6 - 10.0lbs.)</b>
<b>Continuous Usage Time (approx.)</b> Masa Penggunaan Berterusan 连续使用时间	<b>90min Low Speed with BL1850B x2</b>

**DUP361Z**  
RM 6,630

**Battery Powered Pruning Shears**  
Gunting Pemangkas Bateri  
充电式电剪



- Extra sharp, Made-in-Japan forged blade

**Standard Equipment:** Oil Supply, Wrench Set, Diamond File, Cord Holder, Holster, Harness, Arm Band, Tool Bag, Shear Blade

- Z: Without Charger & Battery



**VIDEO CLIP**  
Models and specs may vary by country



<b>Max Output</b> Keluaran Maksima 最大输出	<b>200W</b>
<b>Capacity</b> Kapasiti 能力	<b>Max Cutting : 33mm</b> <b>Max Blade Opening: 54mm</b>
<b>Dimensions (L x W x H)</b> Dimensi 体积	<b>305x43x106mm (12"x1-11/16"x4-3/16")</b>
<b>Net Weight</b> Keberatan 净重	<b>0.8kg (1.8lbs)</b>
<b>Work Amount (approx.)</b> Jumlah Kerja 工作量	<b>71,000cuts with BL1850B x2 (15mm Grape Wine Branch)</b>

**DUP362ZN**  
RM 7,523

**Battery Powered Pruning Shears**  
Gunting Pemangkas Bateri  
充电式电剪



- Extra sharp, Made-in-Japan forged blade

**Standard Equipment:** Oil Supply, Wrench Set, Diamond File, Cord Holder, Holster, Harness, Arm Band, Tool Bag, Shear Blade

- Z: Without Charger & Battery



**VIDEO CLIP**  
Models and specs may vary by country



<b>Max Output</b> Keluaran Maksima 最大输出	<b>200W</b>
<b>Capacity</b> Kapasiti 能力	<b>Max Cutting : 33mm (1-5/16")</b> <b>Max Blade Opening: 54mm</b>
<b>Dimensions (L x W x H)</b> Dimensi 体积	<b>305x43x106mm (12"x1-11/16"x4-3/16")</b>
<b>Net Weight</b> Keberatan 净重	<b>0.77 - 0.82kg (1.7 - 1.8lbs.)</b>
<b>Work Amount (approx.)</b> Jumlah Kerja 工作量	<b>71,000cuts with BL1850B x2 (15mm Grape Wine Branch)</b>



\* All list price shown are for reference only (exclude SST).

\* Semua harga yang ditunjukkan adalah untuk rujukan sahaja (tidak termasuk SST). 所有显示的建议零售价仅供参考 (不包括SST)。

Cordless Target Kord 无绳式  
LED Flashlight Lampu Suluh LED LED 照明灯  
Vacuum Cleaner Pemilauhi Vakuüm 吸尘器  
Drilling / Fastening Druai / Pengikat 钻式 / 螺絲  
Impact Drilling / Demolition Druai / Penembak 钻式 / 拆屋加工  
Cutting Pemotong 切割  
Grinding / Sanding Pengisar / Pucuk 磨削 / 砂磨  
Sawing Cergas 锯切  
Planing / Routing Pengisar / Tangkai 刨削 / 磨削  
Others Lain-lain 其他  
Outdoor Power Equipment Alatan Kerja Luar 园具-户外







Li-ion Ah 6.0 5.0 4.0 3.0 2.0 1.5

# Cordless Lawn Mower

Mesin Pemotong Rumput Tanpa Kord 充电式手推割草机



Recommended mowing area  
Julat memotong yang disyorkan 推荐的割草范围

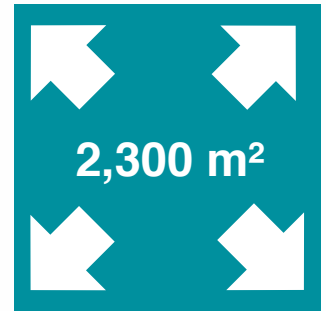

DLM532 with BL1860B x4

Grass level indicator  
Penunjuk tahap rumput 草地高度指示器



empty

full

4 battery slots  
4 slot bateri 4个电池插槽



Child lock key  
Kunci kanak-kanak 儿童锁



Heavy duty handle  
Pemegang tugas berat 重型手柄

Steel Deck  
Dek Keluli 钢甲板

Built-in ball bearing on axles  
for added durability

Gelas bebola terbina dalam pada gandar untuk ketahanan tambahan  
车轴上内置滚珠轴承，增加了耐用性



DLM532Z 534mm (21")  
RM 6,563

Cordless Lawn Mower  
Mesin Pemotong Rumput  
Tanpa Kord  
充电式手推割草机



• IPX4 water resistant for use in bad weather

NEW  
BARU | 新



Blade Hole Diameter Diameter lubang bilah 叶片孔直径	10.0mm (3/8")
Cutting Width Lebar Keratan 切割宽度	534mm (21")
Cutting Height Ketinggian Pemotongan 切割高度	20 - 100mm (13/16" - 3-15/16")
Grass box capacity Kapasiti Kotak Rumput 草箱容量	60L
No Load Speed (RPM) Kelajuan Tanpa Beban 回转速	2,300 - 2,800
Wheel Size Saiz Roda 轮片尺寸	Front / Rear: 230mm (9")
Dimensions (L x W x H) Dimensi 体积	1,630-1,715x590x990-1,095mm (64"-67-1/2"x23-1/4"x39"-43")
Net Weight Berat Bersih 净重	39.0 - 42.8kg (86.0 - 94.4lbs.)
Continuous Usage Time (approx.) Masa Penggunaan Berterusan 连续使用时间	33min (self-propelled)   45min (push-drive) with BL1850B x2

Standard Equipment: Blade, Mulch plug, Side Discharge Mouth, Socket Wrench, Rod

• Z: Without Charger & Battery



\* All list price shown are for reference only (exclude SST).

\* Semua harga yang ditunjukkan adalah untuk rujukan sahaja (tidak termasuk SST). 所有显示的建议零售价仅供参考 (不包括SST)。

Cordless  
Target Area 3.0x3.0m

LED Flashlight  
Lampu Suhu LED  
LED照明灯

Vacuum Cleaner  
Pembersih Vakuum  
吸尘器

Drilling / Fastening  
Ganda / Pasak  
钻孔 / 紧固

Impact Drilling / Demolition  
Ganda / Perusak  
冲击钻孔 / 摧毁施工

Cutting  
Pemotong  
切割

Grinding / Sanding  
Pengamiran / Pasah  
研磨 / 打磨

Sawing  
Gergaji  
锯切

Planing / Routing  
Pergaliran / Tunggam  
刨削 / 埋线

Others  
Lain-lain  
其他

Outdoor Power Equipment  
Alatan Kuasa Luar  
园具/户外





Li-ion Ah 6.0 5.0 4.0 3.0 2.0 1.5

**DLM382PT2 | DLM382Z 380mm (15")**  
Price TBA | Price TBA

**Cordless Lawn Mower**  
Mesin Pemotong Rumput  
Tanpa Kord  
充电式手推割草机



- Zero emissions and reduced maintenance; no need for gas or oil



Standard Equipment: Blade, Mulch Plug, Socket Wrench

- Z: Without Charger & Battery



<b>Cutting Width</b> Lebar Keratan 切割宽度	380mm (15")
<b>Cutting Height</b> Ketinggian Pemotongan 切割高度	20 - 75mm (13/16" - 2-15/16")
<b>Grass box capacity</b> Kapasiti Kotak Rumput 草箱容量	40L
<b>No Load Speed (RPM)</b> Kelajuan Tanpa Beban 回转速数	3,700
<b>Wheel Size</b> Saiz Roda 轮片尺寸	Front: 140mm (5-1/2")   Rear: 160mm (6-5/16")
<b>Dimensions (L x W x H)</b> Dimensi 体积	1,380-1,410x460x985-1,005mm (54-1/4"-55-1/2"x17-3/4"x38-3/4"-39-1/2")
<b>Net Weight</b> Berat Bersih 净重	16.2 - 16.9 kg (35.7 - 37.3 lbs.)
<b>Continuous Usage Time (approx.)</b> Masa Penggunaan Berterusan 连续使用时间	35 min with BL1860B x2

**DLM432PT2 | DLM432Z 430mm (17")**  
Price TBA | Price TBA

**Cordless Lawn Mower**  
Mesin Pemotong Rumput  
Tanpa Kord  
充电式手推割草机



- Low noise level suitable for use in residential areas and public spaces



Standard Equipment: Blade, Mulch Plug, Socket Wrench

- Z: Without Charger & Battery



<b>Cutting Width</b> Lebar Keratan 切割宽度	430mm (17")
<b>Cutting Height</b> Ketinggian Pemotongan 切割高度	20 - 75mm (13/16" - 2-15/16")
<b>Grass box capacity</b> Kapasiti Kotak Rumput 草箱容量	50L
<b>No Load Speed (RPM)</b> Kelajuan Tanpa Beban 回转速数	3,600
<b>Wheel Size</b> Saiz Roda 轮片尺寸	Front: 140mm (5-1/2")   Rear: 160mm (6-5/16")
<b>Dimensions (L x W x H)</b> Dimensi 体积	1,435-1,490x460x1,005-1,045mm (56-1/2"-58-3/4"x18-1/8"x39-1/2"-41-1/4")
<b>Net Weight</b> Berat Bersih 净重	16.8 - 17.5kg (37.0 - 38.6lbs.)
<b>Continuous Usage Time (approx.)</b> Masa Penggunaan Berterusan 连续使用时间	36 min with BL1860B x2

**DLM460Z 460mm (18")**  
RM 3,743

**Cordless Lawn Mower**  
Mesin Pemotong Rumput  
Tanpa Kord  
充电式手推割草机



- IPX4 water resistant for use in bad weather



Standard Equipment: Blade, Socket Wrench

- Z: Without Charger & Battery



<b>Blade Type</b> Jenis Bilah 刀片类型	2 Tooth
<b>Cutting Width</b> Lebar Keratan 切割宽度	460mm (18")
<b>Cutting Height</b> Ketinggian Pemotongan 切割高度	20 - 75mm (13/16" - 2-5/16")
<b>Grass Box Capacity</b> Kapasiti Kotak Rumput 草箱容量	60L
<b>No Load Speed (RPM)</b> Kelajuan Tanpa Beban 回转速数	2,500 - 3,300
<b>Recommended Mowing Area</b> Julat Memotong Yang Disyorkan 推荐的割草范围	With BL1850B x2: 680 - 1,360m <sup>2</sup>
<b>Wheel Size</b> Saiz Roda 轮片尺寸	Front: 180mm (7")   Rear: 205mm (8")
<b>Max Output</b> Keluaran Maksima 最大输出	1,450W
<b>Dimensions (L x W x H)</b> Dimensi 体积	During operation: 1,319-1,518 x 532 x 879-1,138mm (52"-59-3/4" x 21" x 34-1/2"-44-3/4")
<b>Net Weight</b> Berat Bersih 净重	25.3 - 27.6kg (55.8 - 60.8lbs.)
<b>Continuous Usage Time (approx.)</b> Masa Penggunaan Berterusan 连续使用时间	18min with BL1850B x2

**DLM431PT2 | DLM431Z 430mm (17")**  
RM 4,457 | RM 2,872

**Cordless Lawn Mower**  
Mesin Pemotong Rumput  
Tanpa Kord  
充电式手推割草机



- Large 50L capacity grass basket reduces the need for emptying



Standard Equipment: Blade, Socket Wrench

- PT2: 1x Two Port Multi Fast Charger, 2x 5.0Ah Battery
- Z: Without Charger & Battery



<b>Blade Type</b> Jenis Bilah 刀片类型	2 Tooth, Rotary Type
<b>Cutting Width</b> Lebar Keratan 切割宽度	430mm (17")
<b>Cutting Height</b> Ketinggian Pemotongan 切割高度	20 - 75mm (13/16" - 2-15/16")
<b>Grass Box Capacity</b> Kapasiti Kotak Rumput 草箱容量	50L
<b>No Load Speed (RPM)</b> Kelajuan Tanpa Beban 回转速数	3,600
<b>Recommended Mowing Area</b> Julat Memotong Yang Disyorkan 推荐的割草范围	With BL1850B x2: 475 - 950m <sup>2</sup>
<b>Wheel Size</b> Saiz Roda 轮片尺寸	Front: 140mm (5 - 1/2")   Rear: 160mm (6 - 5/16")
<b>Dimensions (L x W x H)</b> Dimensi 体积	1,450-1,490x460x950-1,020mm (57-58-3/4"x18-1/8"x37-1/2"-40-1/4")
<b>Net Weight</b> Keberatan 净重	17.8 - 18.4kg (39.2 - 40.6lbs)
<b>Continuous Usage Time (approx.)</b> Masa Penggunaan Berterusan 连续使用时间	30min with BL1850B x2

**DLM380Z 380mm (15")**  
RM 2,290

**Cordless Lawn Mower**  
Mesin Pemotong Rumput  
Tanpa Kord  
充电式手推割草机



- Zero emissions and reduced maintenance



Standard Equipment: Blade, Wrench

- Z: Without Charger & Battery



<b>Blade Type</b> Jenis Bilah 刀片类型	2 Tooth, Rotary Type
<b>Cutting Width</b> Lebar Keratan 切割宽度	380mm (15")
<b>Cutting Height</b> Ketinggian Pemotongan 切割高度	25 - 75mm (1" - 2-15/16")
<b>Grass Box Capacity</b> Kapasiti Kotak Rumput 草箱容量	40L
<b>No Load Speed (RPM)</b> Kelajuan Tanpa Beban 回转速数	3,700
<b>Recommended Mowing Area</b> Julat Memotong Yang Disyorkan 推荐的割草范围	With BL1830B x2: 270 - 540m <sup>2</sup>
<b>Wheel Size</b> Saiz Roda 轮片尺寸	Front: 140mm (5 - 1/2")   Rear: 190mm (7 - 1/2")
<b>Dimensions (L x W x H)</b> Dimensi 体积	1,145x465x1,023-1,070mm (45"x18-1/4"x40-1/4"-42")
<b>Net Weight</b> Keberatan 净重	14.5kg (32.0lbs)
<b>Continuous Usage Time (approx.)</b> Masa Penggunaan Berterusan 连续使用时间	30min with BL1850B x2

\* All list price shown are for reference only (exclude SST).

\* Semua harga yang ditunjukkan adalah untuk rujukan sahaja (tidak termasuk SST). 所有显示的建议零售价仅供参考 (不包括SST)。

Cordless Target Kord 无绳  
LED Flashlight Lampu Suluh LED LED 手电筒  
Vacuum Cleaner Pembersih Vakuum 吸尘器  
Drilling / Fastening Dremel / Pengikat 钻头 / 紧固件  
Impact Drilling / Demolition Dremel / Penembak Dremel 冲击钻头 / 拆卸加工  
Cutting Pemotong 切割  
Grinding / Sanding Pengisar / Poles 研磨 / 打磨  
Sawing Gergaji 电锯  
Planing / Routing Pengisar / Tangkapan 刨削 / 雕刻  
Others Lain-lain 其他  
Outdoor Power Equipment Alatan Kerosa Luar 户外动力工具





Li-ion Ah 6.0 5.0 4.0 3.0 2.0 1.5

# Cordless Chain Saw

Gergaji Rantai Tanpa Kord 充电式链锯



Jumlah Kerja 工作量  
**Work Amount**  
 with BL1850B x2  
 (50mm Timber)  
**500cuts**  
 (approx.)

\* Continuous Usage Time/ Work Amount:  
 Actual performance may vary based on application.  
 Masa Penggunaan Berterusan/ Jumlah Kerja: Prestasi sebenar  
 mungkin berbeza berdasarkan aplikasi.  
 连续使用时间/ 工作量: 实际性能可能因应用而异。



Net weight  
 Berat Bersih 净重  
**4.6kg**  
 with BL1850B x2  
 5.0Ah Battery

## DUC406Z 400mm (16") RM 3,160

**Cordless Chain Saw**  
 Gergaji Rantai Tanpa Kord  
 充电式链锯



- Low noise level and zero emissions for operator comfort

Standard Equipment: Saw Chain, Guide Bar, Guide Bar Cover, Chain Oil, Socket Wrench

• Z: Without Charger & Battery



<b>Guide Bar Length</b> Panjang Batang Gergaji 切割长度	400mm (16")
<b>Cutting Length</b> Panjang Pemotongan 切割长度	387mm (15-1/4")
<b>Chain Pitch</b> Kerapatan Rantai 链条齿距	3/8"
<b>Chain Gauge</b> Ketebalan Rantai 链条厚度	1.3mm (0.05")
<b>Chain Speed</b> Kelajuan Rantai 链条速度	0 - 20m/s (0 - 1,200 m/min) (0 - 3,940 FPM)
<b>Chain Oil Tank Volume</b> Tangki Minyak Pelincir 链油箱	200mL (6.8 US oz)
<b>Dimensions (L x W x H)</b> Dimensi 体积	270-651x205x232mm (10-5/8"-25-5/8"x8-1/8"x9-1/8")
<b>Net Weight</b> Berat Bersih 净重	5.1kg (11.1lbs.)
<b>Work Amount (approx.)</b> Jumlah Kerja 工作量	500cuts with BL1850B x2 (50mm timber)

## DUC356Z 350mm (14") RM 2,162

**Cordless Chain Saw**  
 Gergaji Rantai Tanpa Kord  
 充电式链锯



- Low noise level and zero emissions for operator comfort

Standard Equipment: Saw Chain, Guide Bar, Guide Bar Cover, Spike Bumper, Chain Oil, Socket Wrench

• Z: Without Charger & Battery



<b>Guide Bar Length</b> Panjang Batang Gergaji 切割长度	350mm (14")
<b>Cutting Length</b> Panjang Pemotongan 切割长度	350mm (14")
<b>Chain Pitch</b> Kerapatan Rantai 链条齿距	9.5mm (3/8")
<b>Chain Gauge</b> Ketebalan Rantai 链条厚度	1.1(0.043") or 1.3mm (0.050")
<b>Chain Speed</b> Kelajuan Rantai 链条速度	0 - 20m/s (0 - 1,200 m/min) (0 - 3,940 FPM)
<b>Chain Oil Tank Volume</b> Tangki Minyak Pelincir 链油箱	200mL (6.8 US oz)
<b>Dimensions (L x W x H)</b> Dimensi 体积	270-651x205x232mm (10-5/8"-25-5/8"x8-1/8"x9-1/8")
<b>Net Weight</b> Berat Bersih 净重	5.1kg (11.1lbs.)
<b>Work Amount (approx.)</b> Jumlah Kerja 工作量	500cuts with BL1850B x2 (50mm timber)

## DUC355Z 350mm (14") RM 2,048

**Cordless Chain Saw**  
 Gergaji Rantai Tanpa Kord  
 充电式链锯



- Constant speed control maintains constant speed under heavy load

Standard Equipment: Saw Chain, Guide Bar, Guide Bar Cover, Chain Oil, Socket Wrench

• Z: Without Charger & Battery



<b>Guide Bar Length</b> Panjang Batang Gergaji 切割长度	350mm (14")
<b>Chain Pitch</b> Kerapatan Rantai 链条齿距	3/8"
<b>Chain Gauge</b> Ketebalan Rantai 链条厚度	1.1mm (0.043")
<b>Chain Speed</b> Kelajuan Rantai 链条速度	0 - 20m/s (0 - 1,200m/min) (0 - 3,940 FPM)
<b>Chain Oil Tank Volume</b> Tangki Minyak Pelincir 链油箱	200mL (N/A US oz)
<b>Dimensions (L x W x H)</b> Dimensi 体积	762x211x235mm (30"x8-5/16"x9-1/4")
<b>Net weight</b> Berat Bersih 净重	4.7 - 5.4kg (10.4 - 11.8lbs.)
<b>Work Amount (approx.)</b> Jumlah Kerja 工作量	550cuts with BL1850B x2 (50mm timber)

\* All list price shown are for reference only (exclude SST).

\* Semua harga yang ditunjukkan adalah untuk rujukan sahaja (tidak termasuk SST). 所有显示的建议零售价仅供参考 (不包括SST)。

Cordless  
Tanda Mata 36V

LED Flashlight  
Lampu Suli LED  
LED 手电筒

Vacuum Cleaner  
Pembersih Vakuum  
吸尘器

Drilling / Fastening  
Gergaji / Pengikat  
电钻 / 螺絲

Impact Drilling / Demolition  
Gergaji / Penebuk  
冲击电钻 / 震裂器

Cutting  
Pangkas  
切割

Grinding / Sanding  
Pengkilan / Poles  
研磨 / 砂磨

Sawing  
Gergaji  
锯切

Planing / Routing  
Pengkilan / Tangkapan  
刨削 / 雕刻

Others  
Lain-lain  
其他

Outdoor Power Equipment  
Alatan Kerja Luar  
园机 / 户外





Li-ion Ah 6.0 5.0 4.0 3.0 2.0 1.5

**DUC353Z** 350mm (14")  
RM 2,237

**Cordless Chain Saw**  
Gergaji Rantai Tanpa Kord  
充电式链锯



- Cordless Chain Saw DUC353 Efficiency Similar to 30ml Class Engine Chain Saw

Standard Equipment: Saw Chain, Guide Bar, Guide Bar Cover, Chain Oil

- Z: Without Charger & Battery



<b>Guide Bar Length</b> Panjang Batang Gergaji 切割长度	350mm (14")
<b>Chain Pitch</b> Kerapatan Rantai 链条齿距	9.5mm (3/8")
<b>Chain Gauge</b> Ketebalan Rantai 链条厚度	1.1/ 1.3mm (0.043" / 0.050")
<b>Chain Speed</b> Kelajuan Rantai 链条速度	0 - 20m/s (0 - 1,200m/min) (0 - 3,940FPM)
<b>Chain Oil Tank Volume</b> Tangki Minyak Pelincir 链油箱	200mL (N/A US oz)
<b>Dimensions (L x W x H)</b> Dimensi 体积	773x215x235mm (30-1/2"x8-1/2"x9-1/4")
<b>Net Weight</b> Keberatan 净重	4.7kg (10.4 lbs)
<b>Work Amount (approx.)</b> Jumlah Kerja 工作量	550cuts with BL1850B x2 (50mm timber)

**DUC252PM4** | **DUC252Z** 250mm (10")  
RM 4,275 | RM 2,032

**Cordless Chain Saw**  
Gergaji Rantai Tanpa Kord  
充电式链锯



- Low noise level and zero emissions for operator comfort

Standard Equipment: Saw Chain, Guide Bar, Guide Bar Cover, Spike Bumper

- PM4: 1 x Two Port Multi Rapid Charger, 4 x 4.0Ah Battery, 1x Tool Bag
- Z: Without Charger & Battery



<b>Guide Bar Length</b> Panjang Batang Gergaji 切割长度	250mm (10")
<b>Chain Pitch</b> Kerapatan Rantai 链条齿距	3/8"
<b>Chain Gauge</b> Ketebalan Rantai 链条厚度	1.3mm (0.05")
<b>Chain Speed</b> Kelajuan Rantai 链条速度	8.3m/s (500m/min) (1,650FPM)
<b>Chain Oil Tank Volume</b> Tangki Minyak Pelincir 链油箱	85mL (2.9US oz)
<b>Dimensions (L x W x H)</b> Dimensi 体积	545x234x198mm (21-1/2"x9-1/4"x7-3/4")
<b>Net Weight</b> Keberatan 净重	4.1 - 4.7kg (9.0 - 10.3lbs)
<b>Work Amount (approx.)</b> Jumlah Kerja 工作量	560cuts with BL1850B x2 (50mm timber)

**Cordless Multi Function Power Head**

Powerhead Pelbagai Fungsi Tanpa Kord  
充电式多功能动力头



**DUX60ZM3** | **DUX60Z**  
RM 2,488 | RM 1,973

**Cordless Multi Function Power Head**  
Powerhead Pelbagai Fungsi Tanpa Kord | 充电式多功能动力头



- Multi-tool system consisting of power head and versatile optional attachments is ideal for a wide range of applications

Standard Equipment: Band Assembly, Hex Wrench, Accessory Bag  
DUX60ZM3: Brushcutter Attachment EM403, Nylon Cutting Head, 3 Tooth Blade, 3 Tooth Blade Cover, Tool Bag, Box Wrench 17, Metal Blade Fixing Tool (Clamp Washer, Nut, Cup)

- Z: Without Charger & Battery • ZM3: Without Charger & Battery



<b>No Load Speed (RPM)</b> Kelajuan Tanpa Beban 回转速	High: 0 - 9,700/ Medium: 0 - 8,200 Low: 0 - 5,700
<b>Dimensions (L x W x H)</b> Dimensi 体积	1,011x320x216mm (39-3/4"x12-5/8"x8-1/2")
<b>Net Weight</b> Berat Bersih 净重	4.1 - 8.7kg (8.9 - 19.2lbs)
<b>Continuous Usage Time (approx.)</b> Masa Penggunaan Berterusan 连续使用时间	Low: 97min   Mid: 35min   High: 21min with BL1850B x2 (Grass Trimmer)

**DUH651Z** 650mm (25-1/2")  
RM 1,903

**Cordless Hedge Trimmer**  
Pemangkas Tanaman Pagar  
Tanpa Kord  
充电式篱笆修剪机



- 5-Position rotating rear handle for increased comfort during vertical and angle trimming

Standard Equipment: Blade Cover

- Z: Without Charger & Battery



<b>Blade Length</b> Panjang bilah 刀片长度	650mm (25-1/2")
<b>Strokes Per Minute (SPM)</b> Kelajuan Strok 冲程速度	2,000 - 3,600
<b>Tooth Spacing</b> Selang Gigi 牙齿间隔	36mm (1-7/16")
<b>Dimensions (L x W x H)</b> Dimensi 体积	1,135x225x200mm (44-3/4"x8-7/8"x7-7/8")
<b>Net Weight</b> Keberatan 净重	4.7 - 5.5kg (10.3 - 12.0lbs)
<b>Continuous Usage Time (approx.)</b> Masa Penggunaan Berterusan 连续使用时间	75 - 125min with BL1850B x2

\* All list price shown are for reference only (exclude SST).

\* Semua harga yang ditunjukkan adalah untuk rujukan sahaja (tidak termasuk SST). 所有显示的建议零售价仅供参考 (不包括SST)。

Cordless Target Kord 无绳式  
LED Flashlight Lampu Suluh LED LED 照明灯  
Vacuum Cleaner Pemilauhi Vakuum 吸尘器  
Drilling / Fastening Daurul / Penamoh 钻孔 / 紧固  
Impact Drilling / Demolition Daurul / Penamoh 冲击钻孔 / 拆除  
Cutting Pemotong 切割  
Grinding / Sanding Pengisar / Pucuk 磨削 / 打磨  
Sawing Gergaji 电锯  
Planing / Routing Pengisar / Tangkap 刨削 / 雕刻  
Others Lain-lain 其他  
Outdoor Power Equipment Alatan Kerja Luar 户外动力设备





Li-ion Ah 6.0 5.0 4.0 3.0 2.0 1.5

# Cordless Blower

Mesin Peniup Tanpa Kord 充电式吹风机



**2 Power modes**  
 Mode 1: Low  
 Mode 2: High  
 2 Mod kuasa  
 2种电源模式

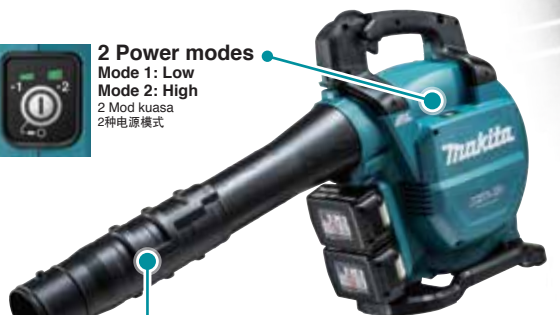

**3-stage telescopic long nozzle with an adjustment range of 100mm (4")**

Teleskopik 3-peringkat panjang muncung dengan pelarasan 100mm (4")  
 三级伸缩长喷嘴, 调节范围为100mm (4")

**72mm diameter nozzle**

DUB362's extension nozzle and flat nozzle can be connected without adapter

Muncung diameter 72mm nozzle penyambung dan muncung rata DUB362 boleh disambungkan tanpa penyambung  
 直径72mm的喷嘴, DUB362的加长喷嘴和扁平喷嘴可在不使用适配器的情况下进行连接



**Sub handle**

makes it easier to hold the machine sideways both in blower and vacuum applications

Pemegang bawah mudah untuk memegang mesin menadkat kedua-dua dalam aplikasi blower dan vakum  
 手柄在鼓风机和真空应用中更容易将机器侧向固定

**Dust Bag Capacity**

Kapasiti beg debu

尘埃容量

**50L**

## DUB362ZV

Price TBA

### Cordless Blower

Mesin Peniup Tanpa Kord  
 充电式吹风机



- Able to use both in Blower and Vacuuming applications

Standard Equipment: Vacuum Kit, Flat Nozzle, End Nozzle, Pipe, Band Assembly, Hex Wrench

• Z: Without Charger & Battery



## DUB362RM2 | DUB362Z

RM 3,432

RM 2,292

### Cordless Blower

Mesin Peniup Tanpa Kord  
 充电式吹风机



- 6-stage air velocity/volume selection dial with variable speed control trigger

Standard Equipment: Nozzle

• RM2: 1x Rapid Charger, 2x 4.0Ah Battery

• Z: Without Charger & Battery



## DUB361Z

RM 1,092

430

### Cordless Blower

Mesin Peniup Tanpa Kord  
 充电式吹风机



- Long blowing nozzle with curved tip for optimal blowing performance

Standard Equipment: Shoulder Belt, Nozzle

• Z: Without Charger & Battery



<b>Max Air Volume</b> Isipadu Angin Maksimum 最大风量	13.4m³/min (473 CFM)
<b>Max Air Velocity</b> Velositi Angin Maksimum 最大风速	65m/s
<b>No Load Speed (RPM)</b> Kelajuan Tanpa Beban 回转数	0 - 7,850
<b>Dimensions (L x W x H)</b> Dimensi 体积	737/786/836x193x415mm (7-7/16"/31"/33"x7-5/8"x16-3/8")
<b>Net Weight</b> Berat Bersih 净重	4.5 - 6.6kg (9.9 - 14.6lbs.)

<b>Max Air Volume</b> Isipadu Angin Maksimum 最大风量	13.4m³/min (473CFM)
<b>Max Air Velocity</b> Velositi Angin Maksimum 最大风速	54m/s (120MPH)
<b>No Load Speed (RPM)</b> Kelajuan Tanpa Beban 回转数	11,400 - 21,500
<b>Dimensions (L x W x H)</b> Dimensi 体积	830/880/930x205x295mm (32-3/4"/34-3/4"/36-5/8"x8-1/8"x11-5/8")
<b>Net Weight</b> Berat Bersih 净重	3.5kg (7.7lbs)
<b>Continuous Usage Time (approx.)</b> Masa Penggunaan Berterusan 连续使用时间	75 With BL1850B x2 (Speed 1)

<b>Max Air Volume</b> Isipadu Angin Maksimum 最大风量	High: 4.4m³/min (155CFM) Low: 2.6m³/min (92CFM)
<b>Max Air Velocity</b> Velositi Angin Maksimum 最大风速	High: 93m/s (208MPH) Low: 57m/s (128MPH)
<b>No Load Speed (RPM)</b> Kelajuan Tanpa Beban 回转数	High: 17,000 Low: 10,000
<b>Dimensions (L x W x H)</b> Dimensi 体积	905x141x194mm (35-5/8"x5-5/8"x7-5/8")
<b>Net Weight</b> Berat Bersih 净重	2.6kg (5.9lbs)
<b>Continuous Usage Time (approx.)</b> Masa Penggunaan Berterusan 连续使用时间	Low: 92min   High: 30min with BL1850B x2

\* All list price shown are for reference only (exclude SST).

\* Semua harga yang ditunjukkan adalah untuk rujukan sahaja (tidak termasuk SST). 所有显示的建议零售价仅供参考 (不包括SST)。

Cordless Targeted Jobs  
 LED Flashlight Lampu Sulu LED LED 闪光灯  
 Vacuum Cleaner Pembasuh Vakum 吸尘器  
 Drilling / Fastening Gergaji / Pasak 钻孔 / 紧固  
 Impact Drilling / Demolition Gergaji / Pasak 冲击钻孔 / 拆除  
 Cutting Pemotong 切割  
 Grinding / Sanding Penggosok / Pasak 研磨 / 打磨  
 Sawing Gergaji 锯切  
 Planing / Routing Penggosok / Tangan 刨平 / 雕刻  
 Others Lain-lain 其他  
 Outdoor Power Equipment Alatan Kuat Luar 户外动力设备





Li-ion Ah 6.0 | 5.0 | 4.0 | 3.0 | 2.0 | 1.5

# Cordless High Pressure Washer

Pembersih Tekanan Tinggi Tanpa Kord 充电式高压清洗机

## Accessories (Optional)

Aksesori 配件

**Cyclone jet nozzle set** (Optional)  
Part No. 197824-4

**Trigger gun set**  
Part No. 197842-2

**High pressure extension hose** (Optional)  
Part No.  
5m 197845-6  
8m 197847-2  
10m 197850-3

**Cyclone guard set** (Optional)  
Part No. 197864-2

**Extension pipe set** (Optional)  
Part No. 197870-7

**High pressure hose** (Optional)  
Part No.  
5m 126766-5 (PVC)  
10m 123784-4 (PVC)  
10m 123651-3 (Rubber)

**Variospray lance set** (Optional)  
Part No. 197876-5

**Twist prevention joint set** (Optional)  
Part No. 197867-6

**Trolley** (Optional)  
Part No. TR00000002  
able to stack on for easy loading

**Foam nozzle set** (Optional)  
Part No. 197886-2

**Wash brush set** (Optional)  
Part No. 197828-6

**Variable nozzle set**  
Part No. 197822-8

**Rotating brush set** (Optional)  
Part No. 197831-7

**Under body spray lance set** (Optional)  
Part No. 197859-5

**Absorption connector set** (Optional)  
Part No. 197881-2

**One touch joint set**  
Part No. 197883-8

**Pipe cleaning hose** (Optional)  
Part No.  
10m 197837-5  
15m 197840-6

**Self-suction hose set**  
Part No. 197873-1

**Accessory joint set** (Optional)  
Part No. 197853-7

### DHW080ZK RM 3,463

**Cordless High Pressure Washer**  
Pembersih Tekanan Tinggi Tanpa Kord  
充电式高压清洗机



- High/ Low 2-pressure selection

**Standard Equipment:** Trigger Gun, High Pressure Hose 5m, Suction Hose, Cleaner Pin, Storage Box, Variable Nozzle, Connector, One Touch Joint

- Z: Without Charger & Battery



<b>Max Permissible Pressure</b> Tekanan Maksimum 最大水压	8.0MPa
<b>Regular Pressure</b> Tekanan Tetap 固定压力	High: 5.5MPa   Low: 3.0MPa
<b>Max Water Flow</b> Aliran Air Maksimum 最大水流量	380L/h (6.3L/min)
<b>Regular Flow</b> Aliran Air Tetap 固定水流量	High: 330L/h (5.5L/min) Low: 240L/h (4.0L/min)
<b>Pump Speed (RPM)</b> Kelajuan Pam 水泵速度	High: 3,450   Low: 2,390
<b>Max Feed Temperature</b> Suhu Maksimum 最高温度	40°C
<b>Tank</b> Kapasiti 容量	50L
<b>Dimensions (L x W x H)</b> Dimensi 体积	438x218x269mm (17-1/4"x8-5/8"x10-5/8")
<b>Net Weight</b> Berat Bersih 净重	7.1 - 7.7kg (15.6 - 17.0lbs.)
<b>Continuous Usage Time (approx.)</b> Masa Penggunaan Berterusan 连续使用时间	High: 12min   Low: 28min with BL1850B x2

\* All list price shown are for reference only (exclude SST).

\* Semua harga yang ditunjukkan adalah untuk rujukan sahaja (tidak termasuk SST). 所有显示的建议零售价仅供参考 (不包括SST)。

Cordless  
Target Model 充电式

LED Flashlight  
Lampu Suluh LED  
LED照明灯

Vacuum Cleaner  
Pembersih Vakuum  
吸尘器

Drilling / Fastening  
Dremel / Pengikat  
钻头 / 螺絲

Impact Drilling / Demolition  
Garuhi / Perseki  
起工钻头 / 拆墙加工

Cutting  
Pengiris  
切割

Grinding / Sanding  
Pengisar / Pasir  
磨削 / 砂纸

Sawing  
Gergaji  
锯切

Planing / Routing  
Pengaram / Tampam  
刨削 / 磨床

Others  
Lain-lain  
其他

Outdoor Power Equipment  
Alatan Keras Luar  
园林-户外





Li-ion Ah 6.0 | 5.0 | 4.0 | 3.0 | 2.0 | 1.5

<b>DDF481RTE</b> RM 2,762	<b>DDF481RME</b> RM 2,615	<b>DDF481RFE</b> RM 2,452	<b>DDF481Z</b> 13mm (1/2") RM 1,477
------------------------------	------------------------------	------------------------------	--



**Cordless Driver Drill**  
Gerudi Pemutar Skru Tanpa Kord  
充电式螺丝起子电钻

- 21 Clutch settings and drill mode for added fastening control

**Standard Equipment:** Side Grip, Belt Clip, (+)(-) Bit, Bit Holder

- RTE: 1x Rapid Charger, 2x 5.0Ah Battery
- RME: 1x Rapid Charger, 2x 4.0Ah Battery
- RFE: 1x Rapid Charger, 2x 3.0Ah Battery
- Z: Without Charger, Battery & Carrying Case

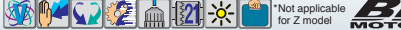

<b>Capacity</b> Kapasiti 能力	Steel: 13mm (1/2") Wood: 76mm (3")
<b>Chuck Capacity</b> Kapasiti Chuck 夹头能力	1.5 - 13mm (1/16 - 1/2")
<b>No Load Speed (RPM)</b> Kelajuan Tanpa Beban 回转数	High: 0 - 2,100   Low: 0 - 550
<b>Max Fastening Torque</b> Maksimum Tenaga Pemutaran Pengancing 最快扭力	Hard: 115N-m (1,020in.lbs.)   Soft: 60N-m (530in.lbs.)
<b>Max Lock Torque</b> Pemutaran Tenaga Maksimum 最大扭矩	125N-m (1,090in.lbs.)
<b>Max Output</b> Keluaran Maksima 最大输出	640W
<b>Dimensions (L x W x H)</b> Dimensi 体积	205x79x266mm (8-1/8"x3-1/8"x10-1/2")
<b>Net Weight</b> Berat Bersih 净重	2.7 - 3.0kg (5.9 - 6.6lbs)
<b>Work Amount (approx.)</b> Jumlah Kerja 工作量	630 holes with BL1850B Wood bit ø21mm (25mm thick Luan)

<b>DDF458RME</b> RM 2,138	<b>DDF458RFE</b> RM 1,973	<b>DDF458Z</b> 13mm (1/2") RM 998	440MM
------------------------------	------------------------------	--------------------------------------	-------



**Cordless Driver Drill**  
Gerudi Pemutar Skru Tanpa Kord  
充电式螺丝起子电钻

- Mechanical 2-speed transmission covers a wide range of drilling and fastening applications

**Standard Equipment:** Side Grip, (+)(-) Bit, Belt Clip, Bit Holder

- RME: 1x Rapid Charger, 2x 4.0Ah Battery
- RFE: 1x Rapid Charger, 2x 3.0Ah Battery
- Z: Without Charger, Battery & Carrying Case



<b>Capacity</b> Kapasiti 能力	Steel: 13mm (1/2") Wood: 76mm (3")
<b>No Load Speed (RPM)</b> Kelajuan Tanpa Beban 回转数	High: 0-2,000   Low: 0-400
<b>Max Fastening Torque</b> Maksimum Tenaga Pemutaran Pengancing 最快扭力	Hard: 91N-m   Soft: 58N-m
<b>Max Lock Torque</b> Pemutaran Tenaga Maksimum 最大扭矩	84N-m (750in.lbs.)
<b>Dimensions (L x W x H)</b> Dimensi 体积	225x79x259mm (8-7/8"x3-1/8"x10-1/4")
<b>Net Weight</b> Berat Bersih 净重	2.1 - 2.5kg (4.7 - 5.4lbs)
<b>Work Amount (approx.)</b> Jumlah Kerja 工作量	500 holes with BL1850B Wood bit ø21mm (25mm thick Luan)

<b>DDF482RME</b> RM 1,833	<b>DDF482RFE</b> RM 1,670	<b>DDF482Z</b> 13mm (1/2") RM 695	440MM
------------------------------	------------------------------	--------------------------------------	-------



**Cordless Driver Drill**  
Gerudi Pemutar Skru Tanpa Kord  
充电式螺丝起子电钻

- High speed model with compact and lightweight design

**Standard Equipment:** Belt Clip, (+)(-) Bit

- RME: 1x Rapid Charger, 2x 4.0Ah Battery
- RFE: 1x Rapid Charger, 2x 3.0Ah Battery
- Z: Without Charger, Battery & Carrying Case



<b>Capacity</b> Kapasiti 能力	Steel: 13mm (1/2") Wood: 38mm (1-1/2")
<b>Chuck Capacity</b> Kapasiti Chuck 夹头能力	1.5 - 13mm (1/16 - 1/2")
<b>No Load Speed (RPM)</b> Kelajuan Tanpa Beban 回转数	High: 0 - 1,900   Low: 0 - 600
<b>Max Fastening Torque</b> Maksimum Tenaga Pemutaran Pengancing 最快扭力	Hard: 62N-m (550in.lbs.)   Soft: 36N-m (320in.lbs.)
<b>Max Lock Torque</b> Pemutaran Tenaga Maksimum 最大扭矩	54N-m (480in.lbs.)
<b>Dimensions (L x W x H)</b> Dimensi 体积	185x79x249mm (7-1/4"x3-1/8"x9-3/4")
<b>Net Weight</b> Berat Bersih 净重	1.5 - 1.8kg (3.2 - 4.0lbs)
<b>Work Amount (approx.)</b> Jumlah Kerja 工作量	781 holes with BL1850B Brad Point Wood bit ø8mm (1" Depth Mixed wood)

<b>DDF484RTE</b> RM 2,242	<b>DDF484RME</b> RM 2,097	<b>DDF484RFE</b> RM 1,932	<b>DDF484Z</b> 13mm (1/2") RM 957
------------------------------	------------------------------	------------------------------	--------------------------------------



**Cordless Driver Drill**  
Gerudi Pemutar Skru Tanpa Kord  
充电式螺丝起子电钻

- Delivers 25% more drilling, driving and fastening speed

**Standard Equipment:** Belt Clip, (+)(-) Bit

- RTE: 1x Rapid Charger, 2x 5.0Ah Battery
- RME: 1x Rapid Charger, 2x 4.0Ah Battery
- RFE: 1x Rapid Charger, 2x 3.0Ah Battery
- Z: Without Charger, Battery & Carrying Case



<b>Capacity</b> Kapasiti 能力	Steel: 13mm (1/2") Wood: 38mm (1-1/2")
<b>Chuck Capacity</b> Kapasiti Chuck 夹头能力	1.5 - 13mm (1/16 - 1/2")
<b>No Load Speed (RPM)</b> Kelajuan Tanpa Beban 回转数	High: 0 - 2,000   Low: 0 - 500
<b>Max Fastening Torque</b> Maksimum Tenaga Pemutaran Pengancing 最快扭力	Hard: 54N-m (480in.lbs.)   Soft: 30N-m (270in.lbs.)
<b>Max Lock Torque</b> Pemutaran Tenaga Maksimum 最大扭矩	60N-m (530in.lbs.)
<b>Dimensions (L x W x H)</b> Dimensi 体积	172x79x261mm (6-3/4"x3-1/8"x10-1/4")
<b>Net Weight</b> Berat Bersih 净重	1.5 - 1.8kg (3.3 - 4.0lbs)
<b>Work Amount (approx.)</b> Jumlah Kerja 工作量	1550 holes with BL1850B Wood bit ø9mm (30mm thick Luan)

<b>DDF485RFE</b> RM 1,760	<b>DDF485Z</b> 13mm (1/2") RM 785
------------------------------	--------------------------------------



**Cordless Driver Drill**  
Gerudi Pemutar Skru Tanpa Kord  
充电式螺丝起子电钻

- Variable 2-speed for a wide range of drilling and fastening applications

**Standard Equipment:** Belt Clip, (+)(-) Bit

- RFE: 1x Rapid Charger, 2x 3.0Ah Battery
- Z: Without Charger, Battery & Carrying Case



<b>Capacity</b> Kapasiti 能力	Steel: 13mm (1/2") Wood: 38mm (1-1/2")
<b>Chuck Capacity</b> Kapasiti Chuck 夹头能力	1.5 - 13mm (1/16 - 1/2")
<b>No Load Speed (RPM)</b> Kelajuan Tanpa Beban 回转数	High: 0- 1,900   Low: 0 - 500
<b>Max Fastening Torque</b> Maksimum Tenaga Pemutaran Pengancing 最快扭力	Hard: 50N-m (440in.lbs.)   Soft: 27N-m (240in.lbs.)
<b>Max Lock Torque</b> Pemutaran Tenaga Maksimum 最大扭矩	50N-m (440in.lbs.)
<b>Max Output</b> Keluaran Maksima 最大输出	350W
<b>Clutch Torque Setting</b> Tetapan Pemutaran 扭转设置	1.0 - 5.0N-m (9 - 44in.lbs.)
<b>Dimensions (L x W x H)</b> Dimensi 体积	169x79x255mm (7-1/8"x3-1/8"x10")
<b>Net Weight</b> Berat Bersih 净重	1.4 - 1.7kg (3.1 - 3.8lbs.)
<b>Work Amount (approx.)</b> Jumlah Kerja 工作量	1400 pcs with BL1850B Auger Bit ø15mm (30mm thick Melapi)

\* All list price shown are for reference only (exclude SST).

\* Semua harga yang ditunjukkan adalah untuk rujukan sahaja (tidak termasuk SST). 所有显示的建议零售价仅供参考 (不包括SST)。

**Cordless**  
Target Aplikasi: 无绳

**LED Flashlight**  
Lampu Saku LED  
LED手电筒

**Vacuum Cleaner**  
Pembersih Vakuum  
吸尘器

**Drilling / Fastening**  
Gerudi / Pengancing  
钻孔 / 紧固

**Impact Drilling / Demolition**  
Gerudi / Penusuk  
冲击钻孔 / 拆除施工

**Cutting**  
Pemotong  
切割

**Grinding / Sanding**  
Pengisar / Poles  
研磨 / 砂磨

**Sawing**  
Gergaji  
锯切

**Planing / Routing**  
Pengayut / Tanggung  
刨削 / 压花

**Others**  
Lain-lain  
其他

**Outdoor Power Equipment**  
Alatan Kuasa Luar  
园具/户外

18V

LXT

Li-ion Ah 6.0 5.0 4.0 3.0 2.0 1.5

**DDF459RME** **DDF459Z** 13mm (1/2")  
RM 1,853 RM 713

**Cordless Driver Drill**  
Gerudi Pemutar Skru Tanpa Kord  
充电式螺丝起子电钻



- Brushless motor delivers up to 50% longer run time per charge

Standard Equipment: Belt Clip, (+/-) Bit

- RME: 1x Rapid Charger, 2x 4.0Ah Battery
- Z: Without Charger, Battery & Carrying Case



<b>Capacity</b> Kapasiti 能力	Steel: 13mm (1/2") Wood: 38mm (1-1/2")
<b>Chuck Capacity</b> Kapasiti Chuck 夹头能力	1.5 - 13mm (1/16 - 1/2")
<b>No Load Speed (RPM)</b> Kelajuan Tanpa Beban 回转速	High: 0 - 1,500   Low: 0 - 400
<b>Max Fastening Torque</b> Maksimum Tenaga Pemutaran Pengancing 最快扭力	Hard: 45N-m (400in.lbs.)   Soft: 25N-m (220in.lbs.)
<b>Max Lock Torque</b> Pemutaran Tenaga Maksimum 最大扭力	45N-m (400in.lbs.)
<b>Dimensions (L x W x H)</b> Dimensi 体积	179x78x256mm (7"x3-1/16"x10-1/8")
<b>Net Weight</b> Berat Bersih 淨重	1.4 - 1.7kg (3.1 - 3.8lbs)
<b>Work Amount (approx.)</b> Jumlah Kerja 工作量	1470 pcs with BL1850B Auger Bit ø15mm (30mm thick Melap)

**DDF453RME** **DDF453RFE** **DDF453SYE** **DDF453Z** 13mm (1/2")  
RM 1,643 RM 1,478 RM 1,343 RM 503

**Cordless Driver Drill**  
Gerudi Pemutar Skru Tanpa Kord  
充电式螺丝起子电钻



- All metal gear construction ensures high transmission durability

Standard Equipment: (+/-) Bit

- RME: 1x Rapid Charger, 2x 4.0Ah Battery
- RFE: 1x Rapid Charger, 2x 3.0Ah Battery
- SYE: 1x Standard Charger, 2x 1.5Ah Battery
- Z: Without Charger, Battery, Bit & Carrying Case



<b>Capacity</b> Kapasiti 能力	Steel: 13mm (1/2") Wood: 36mm (1-7/16")
<b>No Load Speed (RPM)</b> Kelajuan Tanpa Beban 回转速	High: 0-1,300   Low: 0-400
<b>Max Fastening Torque</b> Maksimum Tenaga Pemutaran Pengancing 最快扭力	Hard: 42N-m   Soft: 27N-m
<b>Max Lock Torque</b> Pemutaran Tenaga Maksimum 最大扭力	38N-m (340in.lbs.)
<b>Dimensions (L x W x H)</b> Dimensi 体积	222x79x244mm (8-3/4"x3-1/8"x9-5/8")
<b>Net Weight</b> Berat Bersih 淨重	1.7 - 2.0kg (3.7 - 4.4lbs)
<b>Work Amount (approx.)</b> Jumlah Kerja 工作量	720 pcs with BL1850B Wood screw ø4.1 x 38mm

**DDF483RTE** **DDF483RME** **DDF483RFE** **DDF483Z** 13mm (1/2")  
RM 2,052 RM 1,907 RM 1,743 RM 768

**Cordless Driver Drill**  
Gerudi Pemutar Skru Tanpa Kord  
充电式螺丝起子电钻



- BL motor delivers 40N-m of max torque

Standard Equipment: Belt Clip, (+/-) Bit

- RTE: 1x Rapid Charger, 2x 5.0Ah Battery
- RME: 1x Rapid Charger, 2x 4.0Ah Battery
- RFE: 1x Rapid Charger, 2x 3.0Ah Battery
- Z: Without Charger, Battery & Carrying Case



<b>Capacity</b> Kapasiti 能力	Steel: 13mm (1/2") Wood: 36mm (1-7/16")
<b>Chuck Capacity</b> Kapasiti Chuck 夹头能力	1.5 - 13mm (1/16 - 1/2")
<b>No Load Speed (RPM)</b> Kelajuan Tanpa Beban 回转速	High: 0 - 1,700   Low: 0 - 500
<b>Max Fastening Torque</b> Maksimum Tenaga Pemutaran Pengancing 最快扭力	Hard: 40N-m (350in.lbs.)   Soft: 23N-m (210in.lbs.)
<b>Max Lock Torque</b> Pemutaran Tenaga Maksimum 最大扭力	40N-m (350in.lbs.)
<b>Dimensions (L x W x H)</b> Dimensi 体积	162x79x247mm (6-3/8"x3-1/8"x9-3/4")
<b>Net Weight</b> Berat Bersih 淨重	1.2 - 1.6kg (2.7 - 3.4lbs)
<b>Work Amount (approx.)</b> Jumlah Kerja 工作量	1666 pcs with BL1850B Wood Bit ø9mm (30mm thick Luan)

**DDF083RTE** **DDF083RFE** **DDF083Z** 13mm (1/2")  
RM 2,007 RM 1,698 RM 722

**Cordless Driver Drill**  
Gerudi Pemutar Skru Tanpa Kord  
充电式螺丝起子电钻



- Mechanical 2-speed transmission covers a wide range of drilling and fastening applications

Standard Equipment: Belt Clip, Phillips Bit

- RTE: 1x Rapid Charger, 2x 5.0Ah Battery
- RFE: 1x Rapid Charger, 2x 3.0Ah Battery
- Z: Without Charger, Battery & Carrying Case



<b>Capacity</b> Kapasiti 能力	Steel: 13mm (1/2") Wood: 36mm (1-7/16")
<b>Chuck Capacity</b> Kapasiti Chuck 夹头能力	6.35mm (1/4")
<b>No Load Speed (RPM)</b> Kelajuan Tanpa Beban 回转速	High: 0 - 1,700   Low: 0 - 500
<b>Max Fastening Torque</b> Maksimum Tenaga Pemutaran Pengancing 最快扭力	Hard: 40N-m (350in.lbs.)   Soft: 23N-m (210in.lbs.)
<b>Max Lock Torque</b> Pemutaran Tenaga Maksimum 最大扭力	40N-m (350in.lbs.)
<b>Dimensions (L x W x H)</b> Dimensi 体积	124x79x247mm (4-7/8"x3-1/8"x9-3/4")
<b>Net Weight</b> Berat Bersih 淨重	1.1 - 1.4kg (2.4 - 3.0lbs)
<b>Work Amount (approx.)</b> Jumlah Kerja 工作量	1666 pcs with BL1850B Wood Bit ø9mm (30mm thick Luan)

Model No. 型号	Capacity Kapasiti 能力		No Load Speed (rpm) Kelajuan Tanpa Beban 回转速	Mechanical Speed Mekanikal Kelajuan 机械速度	Torque Setting Tetapan Pemutaran 扭转设置	Max. Fastening Torque Maksimum Tenaga Pemutaran Pengancing 最快扭力	Overall Length (mm) Panjang Keseluruhan 总长度	Net Weight Berat Bersih 淨重	BL MOTOR	XPT
	Steel	Wood								
DDF481	13mm	76mm	0-2,100 / 0-550	2 Speed	21	Hard: 115 / Soft: 60	205	2.7kg (5.9lbs)	●	●
DDF458	13mm	76mm	0-2,000 / 0-400	2 Speed	21	Hard: 91 / Soft: 58	225	2.1kg (4.7lbs)	●	●
DDF482	13mm	38mm	0 - 1,900 / 0 - 600	2 Speed	21	Hard: 62 / Soft: 36	185	1.5kg (3.2lbs)	●	●
DDF484	13mm	38mm	0-2,000 / 0-500	2 Speed	21	Hard: 54 / Soft: 30	172	1.5kg (3.3lbs)	●	●
DDF485	13mm	38mm	0-1,900 / 0-500	2 Speed	21	Hard: 50 / Soft: 27	169	1.4kg (3.1lbs)	●	●
DDF459	13mm	38mm	0-1,500 / 0-400	2 Speed	16	Hard: 45 / Soft: 25	179	1.4kg (3.1lbs)	●	●
DDF453	13mm	36mm	0-1,300 / 0-400	2 Speed	16	Hard: 42 / Soft: 27	222	1.7kg (3.7lbs)	●	●
DDF483	13mm	36mm	0-1,700 / 0-500	2 Speed	20	Hard: 40 / Soft: 23	162	1.2kg (2.7lbs)	●	●
DDF083	13mm	36mm	0-1,700 / 0-500	2 Speed	20	Hard: 40 / Soft: 23	124	1.1kg (2.4lbs)	●	●

\* All list price shown are for reference only (exclude SST).

\* Semua harga yang ditunjukkan adalah untuk rujukan sahaja (tidak termasuk SST). 所有显示的建议零售价仅供参考 (不包括SST)。

Cordless Target Kord 无线式  
LED Flashlight Lampu Suluh LED LED 照明灯  
Vacuum Cleaner Pemilauhi Vakuam 吸尘器  
Drilling / Fastening Druai / Pengait 钻式 / 紧固件  
Impact Drilling / Demolition Druai / Penembak 钻式钻式 / 拆墙加工  
Cutting Pemotong 切割机  
Grinding / Sanding Pengisar / Pasir 磨削 / 砂磨  
Sawing Gergaji 电锯  
Planing / Routing Pengisar / Tangkapan 刨削 / 磨削  
Others Lain-lain 其他  
Outdoor Power Equipment Alatan Kerja Luar 户外户外





# BRUSHLESS MOTOR

Motor tanpa berus 无碳刷马达

- Maintenance-free due to no brush
- Life time work amount of a battery is increased
- Durable against long continuous operation
- More work amount on a single full battery charge

penyenggaraan mudah tanpa proses penggantian berus karbon. Alas yang menggunakan motor berus BL tidak mengalami geseran haba, dengan itu menjadikan bateri lebih tahan lama.

免却更换碳刷的高频工序，保养轻松简单。

采用BL无碳刷马达的工具没有因摩擦热导致的能量流失，所以每次充电后的连续工作时间更长。



# BRUSHED MOTOR

Motor dengan berus 有刷马达

- High power-to-weight ratio obtained by employing 4-pole motor

Berkuasa tinggi dengan motor 4-pole

采用4极马达，高功率

**4-POLE MOTOR** **2-POLE MOTOR**



## Max Fastening Torque

Maksimum Tenaga Pemutaran Pengancing  
最快扭力

Soft Joint

60		<b>DHP481</b> <b>000T</b> <b>Cordless Hammer Driver Drill</b> Tukul Pemutar Skru Bergerudi tanpa Kord 充电式冲击螺丝起子电钻	<b>115</b> N-m
		<b>DDF481</b> <b>00</b> <b>Cordless Driver Drill</b> Gerudi Pemutar Skru tanpa Kord 充电式螺丝起子电钻	110
50		<b>DHP484</b> <b>000T</b> <b>Cordless Hammer Driver Drill</b> Tukul Pemutar Skru Bergerudi tanpa Kord 充电式冲击螺丝起子电钻	100
		<b>DDF484</b> <b>00</b> <b>Cordless Driver Drill</b> Gerudi Pemutar Skru tanpa Kord 充电式螺丝起子电钻	90
40		<b>DHP485</b> <b>000T</b> <b>Cordless Hammer Driver Drill</b> Tukul Pemutar Skru Bergerudi tanpa Kord 充电式冲击螺丝起子电钻	80
		<b>DDF485</b> <b>00</b> <b>Cordless Driver Drill</b> Gerudi Pemutar Skru tanpa Kord 充电式螺丝起子电钻	70
30		<b>DHP482</b> <b>000T</b> <b>Cordless Hammer Driver Drill</b> Tukul Pemutar Skru Bergerudi tanpa Kord 充电式冲击螺丝起子电钻	60
		<b>DDF482</b> <b>00</b> <b>Cordless Driver Drill</b> Gerudi Pemutar Skru tanpa Kord 充电式螺丝起子电钻	60
20		<b>DHP459</b> <b>000T</b> <b>Cordless Hammer Driver Drill</b> Tukul Pemutar Skru Bergerudi tanpa Kord 充电式冲击螺丝起子电钻	50
		<b>DDF459</b> <b>00</b> <b>Cordless Driver Drill</b> Gerudi Pemutar Skru tanpa Kord 充电式螺丝起子电钻	50
10		<b>DHP483</b> <b>000T</b> <b>Cordless Hammer Driver Drill</b> Tukul Pemutar Skru Bergerudi tanpa Kord 充电式冲击螺丝起子电钻	40
		<b>DDF483   DDF083</b> <b>00</b> <b>Cordless Driver Drill</b> Gerudi Pemutar Skru tanpa Kord 充电式螺丝起子电钻	40

## Max Fastening Torque

Maksimum Tenaga Pemutaran Pengancing  
最快扭力

Hard Joint

60		<b>DHP458</b> <b>000T</b> <b>Cordless Hammer Driver Drill</b> Tukul Pemutar Skru Bergerudi tanpa Kord 充电式冲击螺丝起子电钻	<b>91</b> N-m
		<b>DDF458</b> <b>00</b> <b>Cordless Driver Drill</b> Gerudi Pemutar Skru tanpa Kord 充电式螺丝起子电钻	90
50		<b>DHP482</b> <b>000T</b> <b>Cordless Hammer Driver Drill</b> Tukul Pemutar Skru Bergerudi tanpa Kord 充电式冲击螺丝起子电钻	62
		<b>DDF482</b> <b>00</b> <b>Cordless Driver Drill</b> Gerudi Pemutar Skru tanpa Kord 充电式螺丝起子电钻	60
40		<b>DHP453</b> <b>000T</b> <b>Cordless Hammer Driver Drill</b> Tukul Pemutar Skru Bergerudi tanpa Kord 充电式冲击螺丝起子电钻	<b>42</b> N-m
		<b>DDF453</b> <b>00</b> <b>Cordless Driver Drill</b> Gerudi Pemutar Skru tanpa Kord 充电式螺丝起子电钻	40

## Max Fastening Torque

Maksimum Tenaga Pemutaran Pengancing  
最快扭力

Soft Joint

60		<b>DHP458</b> <b>000T</b> <b>Cordless Hammer Driver Drill</b> Tukul Pemutar Skru Bergerudi tanpa Kord 充电式冲击螺丝起子电钻	<b>58</b> N-m
		<b>DDF458</b> <b>00</b> <b>Cordless Driver Drill</b> Gerudi Pemutar Skru tanpa Kord 充电式螺丝起子电钻	50
50		<b>DHP482</b> <b>000T</b> <b>Cordless Hammer Driver Drill</b> Tukul Pemutar Skru Bergerudi tanpa Kord 充电式冲击螺丝起子电钻	<b>36</b> N-m
		<b>DDF482</b> <b>00</b> <b>Cordless Driver Drill</b> Gerudi Pemutar Skru tanpa Kord 充电式螺丝起子电钻	40
40		<b>DHP453</b> <b>000T</b> <b>Cordless Hammer Driver Drill</b> Tukul Pemutar Skru Bergerudi tanpa Kord 充电式冲击螺丝起子电钻	<b>27</b> N-m
		<b>DDF453</b> <b>00</b> <b>Cordless Driver Drill</b> Gerudi Pemutar Skru tanpa Kord 充电式螺丝起子电钻	30

\* All list price shown are for reference only (exclude SST).

\* Semua harga yang ditunjukkan adalah untuk rujukan sahaja (tidak termasuk SST). 所有显示的建议零售价仅供参考 (不包括SST)。

Cordless  
Tangan Kordless

LED Flashlight  
Lampu Suli LED  
LED08881

Vacuum Cleaner  
Pembersih Vakum  
08081

Drilling / Fastening  
Gerudi / Pengancing  
08081

Impact Drilling / Demolition  
Gerudi / Pengancing  
08081

Cutting  
Pemotong  
08081

Grinding / Sanding  
Pengisar / Pemoles  
08081

Sawing  
Gergaji  
08081

Planing / Routing  
Pengisar / Tanggapan  
08081

Others  
Lain-lain  
08081

Outdoor Power Equipment  
Alatan Kuat Luar  
08081

Thakita  
TENT



**DHP481RTE** | **DHP481RFE** | **DHP481Z** 13mm (1/2")  
 RM 2,817 | RM 2,507 | RM 1,532

**Cordless Hammer Driver Drill**  
 Tukul Pemutar Skru Bergerudi Tanpa Kord  
 充电式冲击螺丝起子电钻



- 0-31,500 IPM for fast hammer drilling in masonry materials

Standard Equipment: Depth Gauge, Side Grip, Belt Clip, (+/-) Bit, Bit Holder

- RTE: 1x Rapid Charger, 2x 5.0Ah Battery
- RFE: 1x Rapid Charger, 2x 3.0Ah Battery
- Z: Without Charger, Battery & Carrying Case



<b>Capacity</b> Kapasiti 能力	Steel: 13mm (1/2") Wood: 76mm (3") Masonry: 16mm (5/8")
--------------------------------	---

<b>Chuck Capacity</b> Kapasiti Chuck 夹头能力	1.5 - 13mm (1/16 - 1/2")
--	--------------------------

<b>Impacts Per Minute (IPM)</b> Impak Per Minit 冲击数	High: 0 - 31,500   Low: 0 - 8,250
--	-----------------------------------

<b>No Load Speed (RPM)</b> Kelajuan Tanpa Beban 回转数	High: 0 - 2,100   Low: 0 - 550
--	--------------------------------

<b>Max Fastening Torque</b> Maksimum Tenaga Pemutaran Pengancing 最快扭力	Hard: 115N-m (1,020in.lbs.) Soft: 60N-m (530in.lbs.)
--	---

<b>Max Lock Torque</b> Pemutaran Tenaga Maksimum 最大扭力	125N-m (1,090in.lbs.)
--	-----------------------

<b>Dimensions (L x W x H)</b> Dimensi 体积	205x79x249mm (8-1/8"x3-1/8"x9-3/4")
---	--

<b>Net Weight</b> Berat Bersih 淨重	2.7 - 3.0kg (6.0 - 6.7lbs)
--------------------------------------	----------------------------

<b>Work Amount (approx.)</b> Jumlah Kerja 工作量	630 pcs with BL1850B Wood Screw ø21 x 25mm
--	---

**DHP458RME** | **DHP458RFE** | **DHP458Z** 13mm (1/2") 440  
 RM 2,188 | RM 2,023 | RM 1,048

**Cordless Hammer Driver Drill**  
 Tukul Pemutar Skru Bergerudi Tanpa Kord  
 充电式冲击螺丝起子电钻



- All metal gears and aluminum gear housing for maximum jobsite durability

Standard Equipment: (+/-) Bit, Side Grip, Depth Rod, Bit Holder

- RME: 1x Rapid Charger, 2x 4.0Ah Battery
- RFE: 1x Rapid Charger, 2x 3.0Ah Battery
- Z: Without Charger, Battery & Carrying Case



<b>Capacity</b> Kapasiti 能力	Steel: 13mm (1/2") Wood: 76mm (3") Masonry: 16mm (5/8")
--------------------------------	---

<b>No Load Speed (RPM)</b> Kelajuan Tanpa Beban 回转数	High: 0-2,000   Low: 0-400
--	----------------------------

<b>Impacts Per Minute (IPM)</b> Impak Per Minit 冲击数	High: 0-30,000   Low: 0-6,000
--	-------------------------------

<b>Max Fastening Torque</b> Maksimum Tenaga Pemutaran Pengancing 最快扭力	Hard: 91N-m   Soft: 58N-m
--	---------------------------

<b>Max Lock Torque</b> Pemutaran Tenaga Maksimum 最大扭力	84N-m (750in.lbs.)
--	--------------------

<b>Dimensions (L x W x H)</b> Dimensi 体积	225x79x259mm (8-7/8"x3-1/8"x10-1/4")
---	---

<b>Net Weight</b> Berat Bersih 淨重	2.2 - 2.6kg (4.9 - 5.7lbs)
--------------------------------------	----------------------------

<b>Work Amount (approx.)</b> Jumlah Kerja 工作量	500 pcs with BL1850B Wood Screw ø9 x 25mm
--	--

**DHP482RME** | **DHP482RFE** | **DHP482RFX1** | **DHP482Z** 13mm (1/2") 440  
 RM 1,870 | RM 1,707 | RM 1,748 | RM 732

**Cordless Hammer Driver Drill**  
 Tukul Pemutar Skru Bergerudi Tanpa Kord  
 充电式冲击螺丝起子电钻



- High speed model with compact and lightweight design

Standard Equipment: Belt Clip, (+/-) Bit

- RME: 1x Rapid Charger, 2x 4.0Ah Battery
- RFE: 1x Rapid Charger, 2x 3.0Ah Battery
- RFX1: 1x Rapid Charger, 1x 3.0Ah Battery, Accessories Set
- Z: Without Charger, Battery & Carrying Case



<b>Capacity</b> Kapasiti 能力	Steel: 13mm (1/2") Wood: 38mm (1-1/2") Masonry: 13mm (1/2")
--------------------------------	---

<b>Chuck Capacity</b> Kapasiti Chuck 夹头能力	1.5 - 13mm (1/16 - 1/2")
--	--------------------------

<b>Impacts Per Minute (IPM)</b> Impak Per Minit 冲击数	High: 0 - 28,500   Low: 0 - 9,000
--	-----------------------------------

<b>No Load Speed (RPM)</b> Kelajuan Tanpa Beban 回转数	High: 0 - 1,900   Low: 0 - 600
--	--------------------------------

<b>Max Fastening Torque</b> Maksimum Tenaga Pemutaran Pengancing 最快扭力	Hard: 62N-m (550 in.lbs.) Soft: 36N-m (320 in.lbs.)
--	--

<b>Max Lock Torque</b> Pemutaran Tenaga Maksimum 最大扭力	54N-m (480in.lbs.)
--	--------------------

<b>Dimensions (L x W x H)</b> Dimensi 体积	198x79x249mm (7-3/4"x3-1/8"x9-3/4")
---	--

<b>Net Weight</b> Berat Bersih 淨重	1.5 - 1.8kg (3.4 - 4.1lbs)
--------------------------------------	----------------------------

<b>Work Amount (approx.)</b> Jumlah Kerja 工作量	781 holes with BL1850B Brad Point Wood Bit ø8mm (1" Depth Mixed wood)
--	---

**DHP484RME** | **DHP484RFE** | **DHP484Z** 13mm (1/2")  
 RM 2,152 | RM 1,987 | RM 1,012

**Cordless Hammer Driver Drill**  
 Tukul Pemutar Skru Bergerudi Tanpa Kord  
 充电式冲击螺丝起子电钻



- 0-30,000 IPM for fast hammer drilling in masonry materials

Standard Equipment: Belt Clip, (+/-) Bit

- RME: 1x Rapid Charger, 2x 4.0Ah Battery
- RFE: 1x Rapid Charger, 2x 3.0Ah Battery
- Z: Without Charger, Battery & Carrying Case



<b>Capacity</b> Kapasiti 能力	Steel: 13mm (1/2") Wood: 38mm (1-1/2") Masonry: 13mm (1/2")
--------------------------------	---

<b>Chuck Capacity</b> Kapasiti Chuck 夹头能力	1.5 - 13mm (1/16 - 1/2")
--	--------------------------

<b>Impacts Per Minute (IPM)</b> Impak Per Minit 冲击数	High: 0 - 30,000   Low: 0 - 7,500
--	-----------------------------------

<b>No Load Speed (RPM)</b> Kelajuan Tanpa Beban 回转数	High: 0 - 2,000   Low: 0 - 2,000
--	----------------------------------

<b>Max Fastening Torque</b> Maksimum Tenaga Pemutaran Pengancing 最快扭力	Hard: 54 N-m (480 in.lbs.) Soft: 30 N-m (270 in.lbs.)
--	--

<b>Max Lock Torque</b> Pemutaran Tenaga Maksimum 最大扭力	60N-m (530in.lbs.)
--	--------------------

<b>Dimensions (L x W x H)</b> Dimensi 体积	182x79x261mm (7-1/8"x3-1/8"x10-1/4")
---	---

<b>Net Weight</b> Berat Bersih 淨重	1.6 - 1.9kg (3.5 - 4.2lbs)
--------------------------------------	----------------------------

<b>Work Amount (approx.)</b> Jumlah Kerja 工作量	1850 pcs with BL1850B Wood Screw ø9 x 25mm
--	---

**DHP485RFE** | **DHP485Z** 13mm (1/2")  
 RM 1,795 | RM 820

**Cordless Hammer Driver Drill**  
 Tukul Pemutar Skru Bergerudi Tanpa Kord  
 充电式冲击螺丝起子电钻



- All metal gear construction provides increased durability

Standard Equipment: Belt Clip, (+/-) Bit

- RFE: 1x Rapid Charger, 2x 3.0Ah Battery
- Z: Without Charger, Battery & Carrying Case



<b>Capacity</b> Kapasiti 能力	Steel: 13 (1/2") Wood: 38 (1-1/2") Masonry: 13mm (1/2")
--------------------------------	---

<b>Chuck Capacity</b> Kapasiti Chuck 夹头能力	1.5 - 13mm (1/16 - 1/2")
--	--------------------------

<b>Impacts Per Minute (IPM)</b> Impak Per Minit 冲击数	High: 0 - 28,500   Low: 0 - 7,500
--	-----------------------------------

<b>No Load Speed (RPM)</b> Kelajuan Tanpa Beban 回转数	High: 0 - 1900   Low: 0 - 500
--	-------------------------------

<b>Max Fastening Torque</b> Maksimum Tenaga Pemutaran Pengancing 最快扭力	Hard: 50N-m (440in.lbs.) Soft: 27N-m (240in.lbs.)
--	--

<b>Max Lock Torque</b> Pemutaran Tenaga Maksimum 最大扭力	50N-m (440in.lbs.)
--	--------------------

<b>Dimensions (L x W x H)</b> Dimensi 体积	182x79x255mm (7-1/8"x3-1/8"x10")
---	-------------------------------------

<b>Net Weight</b> Berat Bersih 淨重	1.5 - 1.8kg (3.2 - 3.9lbs.)
--------------------------------------	-----------------------------

<b>Work Amount (approx.)</b> Jumlah Kerja 工作量	1400 pcs with BL1850B Auger Bit ø15mm (30mm thick Melap)
--	---

\* All list price shown are for reference only (exclude SST).

\* Semua harga yang ditunjukkan adalah untuk rujukan sahaja (tidak termasuk SST). 所有显示的建议零售价仅供参考 (不包括SST)。

Cordless Target Kord 无线  
 LED Flashlight Lampu Suluh LED LED 照明灯  
 Vacuum Cleaner Pembersih Vakuum 吸尘器  
 Drilling / Fastening Druai / Penambat 钻孔 / 紧固  
 Impact Drilling / Demolition Druai / Penembak 冲击钻孔 / 拆除加工  
 Cutting Pemotong 切割  
 Grinding / Sanding Pengisar / Poles 磨削 / 打磨  
 Sawing Gergaji 电锯  
 Planing / Routing Pengisar / Tangkap 刨削 / 雕刻  
 Others Lain-lain 其他  
 Outdoor Power Equipment Alatan Kerja Luar 户外户外





Li-ion Ah 6.0 5.0 4.0 3.0 2.0 1.5

**DHP459Z 13mm (1/2")**  
RM 745

**Cordless Hammer Driver Drill**  
Tukul Pemutar Skru Bergerudi Tanpa Kord  
充电式冲击螺丝起子电钻



- Brushless motor delivers up to 50% longer run time per charge

Standard Equipment: Belt Clip, (+/-) Bit

• Z: Without Charger & Battery



<b>Capacity</b> Kapasiti 能力	Steel: 13mm (1/2") Wood: 38mm (1-1/2") Masonry: 13mm (1/2")
<b>Chuck Capacity</b> Kapasiti Chuck 夹头能力	1.5 - 13mm (1/16 - 1/2")
<b>Impacts Per Minute (IPM)</b> Impak Per Minit 冲击数	High: 0 - 22,500   Low: 0 - 6,000
<b>No Load Speed (RPM)</b> Kelajuan Tanpa Beban 回转数	High: 0 - 1,500   Low: 0 - 400
<b>Max Fastening Torque</b> Maksimum Tenaga Pemutaran Pengancing 最快扭力	Hard: 45N-m (400in.lbs.)   Soft: 25N-m (220in.lbs.)
<b>Max Lock Torque</b> Pemutaran Tenaga Maksimum 最大扭矩	45N-m (400in.lbs.)
<b>Dimensions (L x W x H)</b> Dimensi 体积	192x78x256mm (7-9/16"x3-1/16"x10-1/8")
<b>Net Weight</b> Berat Bersih 净重	1.5 - 1.8kg (3.3 - 4.0lbs)
<b>Work Amount</b> Jumlah Kerja 工作量	1470pcs with BL1850B Auger Bit ø15mm (30mm thick Melap)

**DHP453RME DHP453RFE DHP453SYE DHP453Z 13mm (1/2")**  
RM 1,692 RM 1,527 RM 1,393 RM 552

**Cordless Hammer Driver Drill**  
Tukul Pemutar Skru Bergerudi Tanpa Kord  
充电式冲击螺丝起子电钻



- 16 Adjustable torque settings plus drill mode

Standard Equipment: (+/-) Bit

- RME: 1x Rapid Charger, 2x 4.0Ah Battery
- RFE: 1x Rapid Charger, 2x 3.0Ah Battery
- SYE: 1x Standard Charger, 2x 1.5Ah Battery
- Z: Without Charger, Battery & Carrying Case



<b>Capacity</b> Kapasiti 能力	Steel: 13mm (1/2") Wood: 36mm (1-7/16") Masonry: 13mm (1/2")
<b>Impacts Per Minute (IPM)</b> Impak Per Minit 冲击数	High: 0 - 19,500   Low: 0 - 6,000
<b>No Load Speed (RPM)</b> Kelajuan Tanpa Beban 回转数	High: 0 - 1,300   Low: 0 - 400
<b>Max Fastening Torque</b> Maksimum Tenaga Pemutaran Pengancing 最快扭力	Hard: 42N-m   Soft: 27N-m
<b>Max Lock Torque</b> Pemutaran Tenaga Maksimum 最大扭矩	38N-m (340in.lbs.)
<b>Dimensions (L x W x H)</b> Dimensi 体积	240x79x244mm (9-7/16"x3-1/8"x9-5/8")
<b>Net Weight</b> Berat Bersih 净重	1.7 - 2.0kg (3.6 - 4.4lbs)
<b>Work Amount</b> Jumlah Kerja 工作量	720pcs with BL1850B Wood Screw ø4.1 x 38mm

**DHP483RME DHP483RFE DHP483Z 13mm (1/2")**  
RM 1,957 RM 1,792 RM 817

**Cordless Hammer Driver Drill**  
Tukul Pemutar Skru Bergerudi Tanpa Kord  
充电式冲击螺丝起子电钻



- 0-25,500 IPM for fast hammer drilling in masonry materials

Standard Equipment: Belt Clip, (+/-) Bit

- RME: 1x Rapid Charger, 2x 4.0Ah Battery
- RFE: 1x Rapid Charger, 2x 3.0Ah Battery
- Z: Without Charger, Battery & Carrying Case



<b>Capacity</b> Kapasiti 能力	Steel: 13mm (1/2") Wood: 36mm (1-7/16") Masonry: 13mm (1/2")
<b>Chuck Capacity</b> Kapasiti Chuck 夹头能力	1.5 - 13mm (1/16 - 1/2")
<b>Impacts Per Minute (IPM)</b> Impak Per Minit 冲击数	High: 0 - 25,500   Low: 0 - 7,500
<b>No Load Speed (RPM)</b> Kelajuan Tanpa Beban 回转数	High: 0 - 1,700   Low: 0 - 500
<b>Max Fastening Torque</b> Maksimum Tenaga Pemutaran Pengancing 最快扭力	Hard: 40N-m (350 in.lbs.)   Soft: 23N-m (210 in.lbs.)
<b>Max Lock Torque</b> Pemutaran Tenaga Maksimum 最大扭矩	40N-m (350in.lbs.)
<b>Dimensions (L x W x H)</b> Dimensi 体积	176x79x247mm (6-15/16"x3-1/8"x9-3/4")
<b>Net Weight</b> Berat Bersih 净重	1.3 - 1.6kg (2.8 - 3.6lbs)
<b>Work Amount</b> Jumlah Kerja 工作量	200pcs with BL1850B Wood screw ø6 x 75mm

Model No. 型号	Capacity Kapasiti 能力			No Load Speed (rpm) Kelajuan Tanpa Beban 回转数	Impacts Per Minute (IPM) Impak Per Minit 冲击数	Torque Setting Tetapan Pemutaran 扭转设置	Max. Fastening Torque Maksimum Tenaga Pemutaran Pengancing 最快扭力	Overall Length (mm) Panjang Keseluruhan 总长度	Net Weight Berat Bersih 净重	BL MOTOR	XPT
	Steel	Wood	Masonry								
DHP481	13mm	76mm	16mm	0-2,100 / 0-550	High: 0 - 31,500 / Low: 0 - 8,250	21	Hard: 115 / Soft: 60	205	2.7kg (6.0lbs)	●	●
DHP458	13mm	76mm	16mm	0-2,000 / 0-400	High: 0 - 30,000 / Low: 0 - 6,000	21	Hard: 91 / Soft: 58	225	2.2kg (4.9lbs)	●	●
DHP482	13mm	38mm	13mm	0 - 1,900 / 0 - 600	High: 0 - 28,500 / Low: 0 - 9,000	21	Hard: 62 / Soft: 36	198	1.5kg (3.4lbs)	●	●
DHP484	13mm	38mm	13mm	0-2,000 / 0-500	High: 0 - 30,000 / Low: 0 - 7,500	21	Hard: 54 / Soft: 30	182	1.6kg (3.5lbs)	●	●
DHP485	13mm	38mm	13mm	0-1,900 / 0-500	High: 0 - 28,500 / Low: 0 - 7,500	21	Hard: 50 / Soft: 27	182	1.5kg (3.2lbs)	●	●
DHP459	13mm	38mm	13mm	0-1,500 / 0-400	High: 0 - 22,500 / Low: 0 - 6,000	16	Hard: 45 / Soft: 25	192	1.5kg (3.3lbs)	●	●
DHP453	13mm	36mm	13mm	0-1,300 / 0-400	High: 0 - 19,500 / Low: 0 - 6,000	16	Hard: 42 / Soft: 27	240	1.7kg (3.6lbs)	●	●
DHP483	13mm	36mm	13mm	0-1,700 / 0-500	High: 0 - 25,500 / Low: 0 - 7,500	20	Hard: 40 / Soft: 23	176	1.3kg (2.8lbs)	●	●

\* All list price shown are for reference only (exclude SST).

\* Semua harga yang ditunjukkan adalah untuk rujukan sahaja (tidak termasuk SST). 所有显示的建议零售价仅供参考 (不包括SST)。

Cordless Targeted Jobs

LED Flashlight Lampu Suli LED LED照明灯

Vacuum Cleaner Pembersih Vakuum 吸尘器

Drilling / Fastening Gantol / Pengantol 钻孔 / 紧固

Impact Drilling / Demolition Gantol / Pengantol 冲击钻孔 / 拆除

Cutting Pemotong 切割

Grinding / Sanding Pengamiran / Pemoles 研磨 / 砂磨

Sanding / Grinding 砂磨 / 研磨

Planing / Routing Pengayutan / Tumpang 刨平 / 榫接

Others Lain-lain 其他

Outdoor Power Equipment Alatan Kerja Luar 户外动力工具

Cordless Target Kord 无绳式  
LED Flashlight Lampu Suluh LED LED 手电筒  
Vacuum Cleaner Pemilauh Vakuum 吸尘器  
Drilling / Fastening Daurul / Pengikat 钻孔 / 紧固  
Impact Drilling / Demolition Daurul / Persekolah 冲击钻孔 / 拆除加工  
Cutting Pemotong 切割  
Grinding / Sanding Pengisar / Piskin 磨削 / 打磨  
Sawing Daging 锯切  
Planing / Routing Pengisar / Tangkapan 刨削 / 雕刻  
Others Lain-lain 其他  
Outdoor Power Equipment Alatan Korsa Luar 户外动力设备

# BRUSHLESS MOTOR

Motor tanpa berus 无碳刷马达

- Maintenance-free due to no brush
  - Life time work amount of a battery is increased
  - Durable against long continuous operation
  - More work amount on a single full battery charge
- penyelenggaraan mudah tanpa proses penggantian berus karbon  
Alat yang menggunakan motor berus BL tidak mengalami geseran haba, dengan itu menjadikan bateri lebih tahan lama  
免却更换碳刷的前道工序，保养较简单  
采用BL无碳刷马达的工具没有因摩擦热导致的能量流失，所以每次充电后的连续工作时间更长



# BRUSHED MOTOR

Motor dengan berus 有刷马达

- High power-to-weight ratio obtained by employing 4-pole motor
- Berkuasa tinggi dengan motor 4-pole  
采用4极马达，高功率



4-POLE MOTOR

## Max Fastening Torque

Maksimum Tenaga Pemutaran Pengancing 最大扭矩

180 N·m

175 N·m

170 N·m

165 N·m

140 N·m

## A mode [assist mode]

helps to eliminate "screw cam-out" and "cross threading" by driving at low speed until the start of tightening.

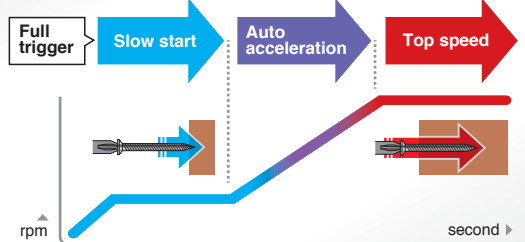

**DTD171**

**Cordless Impact Driver**  
Pemutar Skru Impak tanpa Kord 充电式冲击螺丝起子机

**BL MOTOR XPT**

4 STAGE power selection + TEKS MODE

A +



**DTD170**

**Cordless Impact Driver**  
Pemutar Skru Impak tanpa Kord 充电式冲击螺丝起子机

**BL MOTOR XPT**

4 STAGE power selection + TEKS MODE + A



**DTD154**

**Cordless Impact Driver**  
Pemutar Skru Impak tanpa Kord 充电式冲击螺丝起子机

**BL MOTOR XPT**

3 STAGE power selection + TEKS MODE



**DTD153**

**Cordless Impact Driver**  
Pemutar Skru Impak tanpa Kord 充电式冲击螺丝起子机

**BL MOTOR XPT**

Ideal for applications such as tightening of self-drilling screws



**DTD155**

**Cordless Impact Driver**  
Pemutar Skru Impak tanpa Kord 充电式冲击螺丝起子机

**BL MOTOR XPT**

2 STAGE power selection + A

**DTD149**

**Cordless Impact Driver**  
Pemutar Skru Impak tanpa Kord 充电式冲击螺丝起子机

**XPT 4-POLE MOTOR**



**DTD152**

**Cordless Impact Driver**  
Pemutar Skru Impak tanpa Kord 充电式冲击螺丝起子机

**XPT 4-POLE MOTOR**

Ideal for applications such as tightening of self-drilling screws



**DTS141**

**Cordless Oil-Pulse Driver**  
Pemutar Skru Impak tanpa Kord 充电式冲击起子机

**BL MOTOR XPT**

3 STAGE power selection + TEKS MODE

Suitable for noise sensitive job site

**SOFT IMPACT**

Low Noise 77dB

40 N·m



**DTP141**

**Cordless 4 Mode Impact Driver**  
Pemutar Skru Impak tanpa Kord 充电式冲击螺丝起子机

**BL MOTOR**

3 STAGE power selection + TEKS MODE

4 Operation modes  
Impact driver/  
Hammer drill/ Drill/  
Screwdriver



150 N·m



"Teks" mode is a special mode optimum for fast tightening of self drilling screws without damaging the screw and the workpiece.

"Teks" mod adalah mod khas yang optimum untuk mengikatkan skru penggerudian sendiri tanpa cepat merosakkan skru dan bahan kerja.

"Teks" 模式是一种特殊模式，可以在不损坏螺钉和工件的情况下快速拧紧自攻螺钉。

**Teks mode**

\* All list price shown are for reference only (exclude SST).

\* Semua harga yang ditunjukkan adalah untuk rujukan sahaja (tidak termasuk SST). 所有显示的建议零售价仅供参考 (不包括SST)。

18V

LXT

Li-ion Ah 6.0 5.0 4.0 3.0 2.0 1.5

# Cordless Impact Driver

Pemutar Skru Impak Tanpa Kord 充电式冲击螺丝起子机

## 4 ASSIST MODE

4 jenis mod kerja 4 协助工作模式

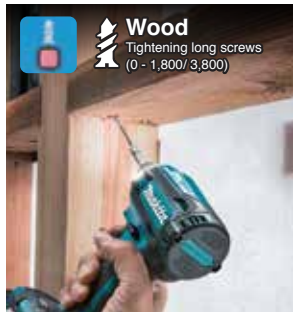

**BALL BEARING** provides reduction of bit wobbling

Gelas bola mengurangkan goyangan kepada mata gerudi  
滚珠轴承可减少钻头摆动

**One touch bit installation**

Pemasangan satu klik  
一键式安装

**Quick mode-switching function**

Mod kawalan manual  
手动直接控制模式开关

**Variable Speed Control by Trigger**

Pencetus kawalan kelajuan  
触发控制变速

## 4 STAGE IMPACT POWER SELECTION

Pemilihan kuasa 4 peringkat 4 模式冲击力选择

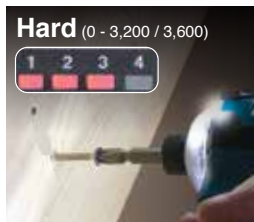

**DTD171RTJ** RM 2,762 | **DTD171RFJ** RM 2,452 | **DTD171Z** RM 1,477

**Cordless Impact Driver**  
Pemutar Skru Impak Tanpa Kord  
充电式冲击螺丝起子机



• Ultra Compact and perfect balance at only 116mm long

Standard Equipment: Belt Clip

- RTJ: 1x Rapid Charger, 2x 5.0Ah Battery, 1x Makpac Connector Box
- RFJ: 1x Rapid Charger, 2x 3.0Ah Battery, 1x Makpac Connector Box
- Z: Without Charger, Battery & Carrying Case



\*Not applicable for Z model



<b>Capacity</b> Kapasiti 能力	Machine Screw: M4 - M8 (5/32" - 5/16") Standard Bolt: M5 - M16 (3/16" - 5/8") High Tensile Bolt: M5 - M14 (3/16" - 9/16") Coarse thread (in length): 22 - 125mm (7/8" - 4-7/8") 6.35mm (1/4")
<b>Hex Shank</b> Batang Heksagon 六角柄	
<b>No Load Speed (RPM)</b> Kelajuan Tanpa Beban 回转数	Max/ Hard/ Med/ Soft/ Wood/ Bolt/ T(1) T(2) mode: 0 - 3,600 / 3,200 / 2,100 / 1,100 / 1,800 / 3,600 / 2,900 / 3,600
<b>Impacts Per Minute (IPM)</b> Impak Per Minit 冲击数	Max/ Hard/ Med/ Soft/ Wood/ Bolt/ T(1) T(2) mode: 0 - 3,800 / 3,600 / 2,600 / 1,100 / 3,800 / 3,800 / N/A / 2,600
<b>Max Fastening Torque</b> Maksimum Tenaga Pemutaran Pengancing 最快扭力	180N-m (1,590in.lbs.)
<b>Fastening Torque</b> Tenaga Pemutaran Pengancing 扭力	Hard: 170N-m (1,510in.lbs.)   Med: 50N-m (440in.lbs.)   Soft: 20 N-m (180 in.lbs.)
<b>Dimensions (L x W x H)</b> Dimensi 体积	116x79x236mm (4-9/16"x3-1/8"x9-1/4")
<b>Net Weight</b> Berat Bersih 净重	1.2 - 1.6kg (2.7 - 3.4lbs.)
<b>Work Amount (approx.)</b> Jumlah Kerja 工作量	808 pcs with BL1850B coarse thread screw 65mm

**DTD170RME** RM 2,553 | **DTD170RFE** RM 2,390 | **DTD170Z** RM 1,415

**Cordless Impact Driver**  
Pemutar Skru Impak Tanpa Kord  
充电式冲击螺丝起子机



• 6-Mode operation for A-mode/ T-mode/ Max/ Hard/ Medium/ Soft impact mode for multiple applications

Standard Equipment: Belt Clip

- RME: 1x Rapid Charger, 2x 4.0Ah Battery
- RFE: 1x Rapid Charger, 2x 3.0Ah Battery
- Z: Without Charger, Battery & Carrying Case



\*Not applicable for Z model



<b>Capacity</b> Kapasiti 能力	Machine Screw: M4 - M8 (5/32" - 5/16") Standard Bolt: M5 - M16 (3/16" - 5/8") High Tensile Bolt: M5 - M14 (3/16" - 9/16") Coarse Thread (in length): 22 - 125mm (7/8" - 4-7/8") 6.35mm (1/4")
<b>Hex Shank</b> Batang Heksagon 六角柄	
<b>No Load Speed (RPM)</b> Kelajuan Tanpa Beban 回转数	Max: 0 - 3,600   Hard: 3,200   Med: 2,100   Soft: 1,100   T Mode: 3,600
<b>Impacts Per Minute (IPM)</b> Impak Per Minit 冲击数	Max: 0 - 3,800   Hard: 3,600   Med: 2,600   Soft: 1,100   T mode: 2,600
<b>Max Fastening Torque</b> Maksimum Tenaga Pemutaran Pengancing 最快扭力	175N-m (1,550in.lbs.)
<b>Dimensions (L x W x H)</b> Dimensi 体积	117x79x236mm (4-5/8"x3-1/8"x9-1/4")
<b>Net Weight</b> Berat Bersih 净重	1.2 - 1.5kg (2.7 - 3.4lbs)
<b>Work Amount (approx.)</b> Jumlah Kerja 工作量	808 pcs with BL1850B coarse thread screw 65mm

\* All list price shown are for reference only (exclude SST).

\* Semua harga yang ditunjukkan adalah untuk rujukan sahaja (tidak termasuk SST). 所有显示的建议零售价仅供参考 (不包括SST)。

Cordless  
Target: No Cord

LED Flashlight  
Lampu Suka LED  
LED 闪光灯

Vacuum Cleaner  
Pembersih Vakuum  
吸尘器

Drilling / Fastening  
Gerudi / Pengasing  
钻孔 / 紧螺

Impact Drilling / Demolition  
Gerudi / Pengasing  
冲击钻孔 / 拆毁施工

Cutting  
Pemotong  
切割

Grinding / Sanding  
Pengisar / Pechin  
打磨 / 砂磨

Sanding  
Gergaji  
锯切

Planing / Routing  
Pengisar / Tanggung  
刨削 / 雕刻

Others  
Lain-lain  
其他

Outdoor Power Equipment  
Alatan Kuat Luar  
园机/户外

Makita  
1945



Li-ion Ah 6.0 | 5.0 | 4.0 | 3.0 | 2.0 | 1.5

Cordless  
Tanpa Kord / Cordless

LED Flashlight  
Lampu Suluh LED  
LED 照明灯

Vacuum Cleaner  
Pembersih Vakuum  
吸尘器

Drilling / Fastening  
Ganjal / Pengikat  
钻孔 / 紧固

Impact Drilling / Demolition  
Ganjal / Perusak  
起工钻孔 / 拆墙加工

Cutting  
Pemotong  
切割

Grinding / Sanding  
Pengisar / Poles  
磨削 / 打磨

Sawing  
Gergaji  
电锯

Planing / Routing  
Pengisar / Tangkai  
刨削 / 雕刻

Others  
Lain-lain  
其他

Outdoor Power Equipment  
Alatan Kerja Luar  
园林-户外



**DTD154RME** | **DTD154RFE** | **DTD154Z**  
RM 2,127 | RM 1,963 | RM 988

**Cordless Impact Driver**  
Pemutar Skru Impak Tanpa Kord  
充电式冲击螺丝起子机



- Aluminum hammer case creates the impression of rigidity of the machine

Standard Equipment: Belt Clip

- RME: 1x Rapid Charger, 2x 4.0Ah Battery
- RFE: 1x Rapid Charger, 2x 3.0Ah Battery
- Z: Without Charger, Battery & Carrying Case



<b>Capacity</b> Kapasiti 能力	Machine Screw: M4 - M8 (5/32" - 5/16") Standard Bolt: M5 - M16 (3/16" - 5/8") High Tensile Bolt: M5 - M14 (3/16" - 9/16") Coarse Thread (in length): 22 - 125mm (7/8" - 4-7/8") 6.35mm (1/4")
<b>Hex Shank</b> Batang Heksagon 六角柄	
<b>No Load Speed (RPM)</b> Kelajuan Tanpa Beban 回转数	0 - 3,600   0 - 2,100   0 - 1,100
<b>Impacts Per Minute (IPM)</b> Impak Per Minit 冲击数	0 - 3,800   0 - 2,600   0 - 1,100
<b>Max Fastening Torque</b> Maksimum Tenaga Pemutaran Pengancing 最快扭力	175N-m (1,550in.lbs.)
<b>Dimensions (L x W x H)</b> Dimensi 体积	117x79x236mm (4-5/8"x3-1/8"x9-1/4")
<b>Net Weight</b> Berat Bersih 淨重	1.3 - 1.6kg (2.7 - 3.4lbs)
<b>Work Amount (approx.)</b> Jumlah Kerja 工作量	800 pcs with BL1850B Wood screw ø4.3 x 65mm

**DTD153RTE** | **DTD153RFE** | **DTD153Z**  
RM 2,102 | RM 1,792 | RM 817

**Cordless Impact Driver**  
Pemutar Skru Impak Tanpa Kord  
充电式冲击螺丝起子机



- Aluminum hammer case creates the impression of rigidity of the machine

Standard Equipment: Belt Clip

- RTE: 1x Rapid Charger, 2x 5.0Ah Battery
- RFE: 1x Rapid Charger, 2x 3.0Ah Battery
- Z: Without Charger, Battery & Carrying Case



<b>Capacity</b> Kapasiti 能力	Machine Screw: M4 - M8 (5/32" - 5/16") Standard Bolt: M5 - M16 (3/16" - 5/8") High Tensile Bolt: M5 - M14 (3/16" - 9/16") Coarse Thread (in length): 22 - 125mm (7/8" - 4-7/8") 6.35mm (1/4")
<b>Hex Shank</b> Batang Heksagon 六角柄	
<b>No Load Speed (RPM)</b> Kelajuan Tanpa Beban 回转数	0 - 3,400
<b>Impacts Per Minute (IPM)</b> Impak Per Minit 冲击数	0 - 3,600
<b>Max Fastening Torque</b> Maksimum Tenaga Pemutaran Pengancing 最快扭力	170N-m (1,500in.lbs.)
<b>Dimensions (L x W x H)</b> Dimensi 体积	126x79x238mm (5"x3-1/8"x9-3/8")
<b>Net Weight</b> Berat Bersih 淨重	1.3 - 1.6kg (2.8 - 3.5lbs)
<b>Work Amount (approx.)</b> Jumlah Kerja 工作量	760 pcs with BL1850B Wood screw 65mm

**DTD149RFE** | **DTD149Z**  
RM 1,737 | RM 762

**Cordless Impact Driver**  
Pemutar Skru Impak Tanpa Kord  
充电式冲击螺丝起子机



- Developed for main applications such as tightening of self-drilling screws or light duty machine screws

Standard Equipment: Belt Clip

- RFE: 1x Rapid Charger, 2x 5.0Ah Battery
- Z: Without Charger, Battery & Carrying Case



<b>Capacity</b> Kapasiti 能力	Machine Screw: M4 - M8 (5/32" - 5/16") Standard Bolt: M5 - M14 (3/16" - 9/16") High Tensile Bolt: M5 - M12 (3/16" - 1/2") Coarse Thread (in length): 22 - 125mm (7/8" - 4-7/8") 6.35mm (1/4")
<b>Hex Shank</b> Batang Heksagon 六角柄	
<b>No Load Speed (RPM)</b> Kelajuan Tanpa Beban 回转数	0 - 2,500
<b>Impacts Per Minute (IPM)</b> Impak Per Minit 冲击数	0 - 3,200
<b>Max Fastening Torque</b> Maksimum Tenaga Pemutaran Pengancing 最快扭力	165N-m (1,460in.lbs.)
<b>Dimensions (L x W x H)</b> Dimensi 体积	135x79x238mm (5-5/16"x3-1/8"x9-3/8")
<b>Net Weight</b> Berat Bersih 淨重	1.3 - 1.6kg (2.8 - 3.5lbs)
<b>Work Amount (approx.)</b> Jumlah Kerja 工作量	533 pcs with BL1850B Wood screw ø4.3 x 65mm

**DTD152RME** | **DTD152RFE** | **DTD152Z**  
RM 1,902 | RM 1,737 | RM 762

**Cordless Impact Driver**  
Pemutar Skru Impak Tanpa Kord  
充电式冲击螺丝起子机



- Aluminum hammer case creates the impression of rigidity of the machine

Standard Equipment: Belt Clip

- RME: 1x Rapid Charger, 2x 4.0Ah Battery
- RFE: 1x Rapid Charger, 2x 3.0Ah Battery
- Z: Without Charger, Battery & Carrying Case



<b>Capacity</b> Kapasiti 能力	Machine Screw: M4 - M8 (5/32" - 5/16") Standard Bolt: M5 - M16 (3/16" - 5/8") High Tensile Bolt: M5 - M12 (3/16" - 1/2") Coarse Thread (in length): 22 - 125mm (7/8" - 4-7/8") 6.35mm (1/4")
<b>Hex Shank</b> Batang Heksagon 六角柄	
<b>No Load Speed (RPM)</b> Kelajuan Tanpa Beban 回转数	0 - 2,900
<b>Impacts Per Minute (IPM)</b> Impak Per Minit 冲击数	0 - 3,500
<b>Max Fastening Torque</b> Maksimum Tenaga Pemutaran Pengancing 最快扭力	165N-m (1,460 in.lbs.)
<b>Dimensions (L x W x H)</b> Dimensi 体积	137x79x238mm (5-3/8"x3-1/8"x9-3/8")
<b>Net Weight</b> Berat Bersih 淨重	1.3 - 1.6kg (2.8 - 3.5lbs)
<b>Work Amount (approx.)</b> Jumlah Kerja 工作量	603 pcs with BL1850B Hex screw 3/4" (Holding sheet 0.23mm RHS 1.6mm)

**DTD156SF** | **DTD156Z**  
RM 988 | RM 340

**Cordless Impact Driver**  
Pemutar Skru Impak Tanpa Kord  
充电式冲击螺丝起子机



- Compact, lightweight but powerful 4-pole motor

Standard Equipment: Belt Clip

- SF: 1x Standard Charger, 1x 3.0Ah Battery
- Z: Without Charger, Battery & Carrying Case

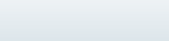
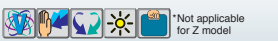

<b>Capacity</b> Kapasiti 能力	Machine Screw: M4 - M8 (5/32" - 5/16") Standard Bolt: M5 - M14 (3/16" - 9/16") High Strength Bolt: M5 - M12 (3/16" - 1/2") Coarse Thread (in length): 22 - 125mm (7/8" - 4-7/8")
<b>Hex Shank</b> Batang Heksagon 六角柄	6.35mm (1/4")
<b>No Load Speed (RPM)</b> Kelajuan Tanpa Beban 回转数	0 - 2,500
<b>Impacts Per Minute (IPM)</b> Impak Per Minit 冲击数	0 - 3,000
<b>Max Fastening Torque</b> Maksimum Tenaga Pemutaran Pengancing 最快扭力	155N-m (1,370in.lbs.)
<b>Dimensions (L x W x H)</b> Dimensi 体积	143x79x241mm (5-5/8"x3-1/8"x9-1/2")
<b>Net Weight</b> Berat Bersih 淨重	1.3 - 1.6kg (2.9 - 3.6lbs.)

\* All list price shown are for reference only (exclude SST).

\* Semua harga yang ditunjukkan adalah untuk rujukan sahaja (tidak termasuk SST). 所有显示的建议零售价仅供参考 (不包括SST)。



Li-ion Ah 6.0 5.0 4.0 3.0 2.0 1.5

**DTD155RME DTD155Z**  
RM 1,912 RM 773

**Cordless Impact Driver**  
Pemutar Skru Impak Tanpa Kord  
充电式冲击螺丝起子机



- 3-Mode operation for A-mode / Hard mode / Soft mode for multiple applications

Standard Equipment: Belt Clip

- RME: 1x Rapid Charger, 2x 4.0Ah Battery
- Z: Without Charger, Battery & Carrying Case



\*Not applicable for Z model



<b>Capacity</b> Kapasiti 能力	<b>Machine Screw:</b> M4 - M8 mm (5/32" - 5/16") <b>Standard Bolt:</b> M5 - M14 (3/16" - 9/16") <b>High Tensile Bolt:</b> M5 - M12 (3/16" - 1/2") <b>Coarse Thread (in length):</b> 22 - 90mm (7/8" - 3-1/2") 6.35mm (1/4")
<b>Hex Shank</b> Batang Heksagon 六角柄	
<b>No Load Speed (RPM)</b> Kelajuan Tanpa Beban 回转数	<b>Hard:</b> 0 - 3,000   <b>Soft:</b> 0 - 1,300
<b>Impacts Per Minute (IPM)</b> Impak Per Minit 冲击数	<b>Hard:</b> 0 - 3,900   <b>Soft:</b> 0 - 1,600
<b>Max Fastening Torque</b> Maksimum Tenaga Pemutaran Pengancing 最快扭力	140N-m (1,240in.lbs.)
<b>Dimensions (L x W x H)</b> Dimensi 体积	135x79x232mm (5-5/16"x3-1/8"x9-1/8")
<b>Net Weight</b> Berat Bersih 淨重	1.2 - 1.5kg (2.6 - 3.2lbs)
<b>Work Amount (approx.)</b> Jumlah Kerja 工作量	725 pcs with BL1850B coarse thread screw 65mm (melapi)

**DTP141RFE DTP141Z**  
RM 2,845 RM 1,868

**Cordless 4 Mode Impact Driver**  
Pemutar Skru Impak Tanpa Kord  
充电式冲击螺丝起子机



- 4 Operation Modes (Impact Driver, Hammer Drill, Drill, Screwdriver) and Teks Screw Mode selection

Standard Equipment: Belt Clip

- RFE: 1x Rapid Charger, 2x 3.0Ah Battery
- Z: Without Charger, Battery & Carrying Case



\*Not applicable for Z model



<b>Capacity</b> Kapasiti 能力	<b>Steel:</b> 10mm (3/8")   <b>Wood:</b> 21mm (13/16") <b>Masonry:</b> 8mm (5/16")
<b>No Load Speed (RPM)</b> Kelajuan Tanpa Beban 回转数	<b>Impact-driver Mode:</b> <b>Hard:</b> 0 - 2,700   <b>Medium:</b> 0 - 2,200   <b>Soft:</b> 0 - 1,300 <b>Drill Mode High:</b> 0 - 2,700   <b>Low:</b> 0 - 700 <b>Hammer Drill Mode High:</b> 0 - 2,700   <b>Low:</b> 0 - 700 <b>Screwdriver Mode High:</b> 0 - 1,100   <b>Low:</b> 0 - 300
<b>Impacts Per Minute (IPM)</b> Impak Per Minit 冲击数	<b>Impact-driver Mode (Hard: 0-3,200   Medium: 0-2,400   Soft: 0-1,200)</b> <b>Hammer Drill Mode (Hi: 0 - 32,400   Lo: 0 - 8,400)</b>
<b>Max Fastening Torque</b> Maksimum Tenaga Pemutaran Pengancing 最快扭力	<b>Impact-driver Mode:</b> 150N-m (1,330in.lbs.) <b>Drill Mode (Hard/ Soft):</b> 22/ 13N-m
<b>Dimensions (L x W x H)</b> Dimensi 体积	171x79x250mm (6-3/4"x3-1/8"x9-7/8")
<b>Net Weight</b> Berat Bersih 淨重	1.5 - 1.9kg (3.4 - 4.1lbs)

**DTS141RFE DTS141Z**  
RM 3,183 RM 2,207

**Cordless Oil-Pulse Driver**  
Pemutar Skru Impak Tanpa Kord  
充电式冲击起子机



- Low noise level of 77dB

Standard Equipment: Belt Clip

- RFE: 1x Rapid Charger, 2x 3.0Ah Battery
- Z: Without Charger, Battery & Carrying Case



\*Not applicable for Z model



VIDEO CLIP  
Models and specs may vary by country

<b>Capacity</b> Kapasiti 能力	<b>Machine Screw:</b> M4 - M8 (5/32" - 5/16") <b>Standard Bolt:</b> M5 - M8 (3/16" - 5/16") <b>High Tensile Bolt:</b> M5 - M6 (3/16" - 1/4") <b>Coarse Thread (in length):</b> 22 - 125mm (7/8" - 4-7/8") <b>Hard:</b> 0-3,200   <b>Medium:</b> 0-2,000   <b>Soft:</b> 0-1,200
<b>No Load Speed (RPM)</b> Kelajuan Tanpa Beban 回转数	<b>Hard:</b> 0-2,700   <b>Medium:</b> 0-2,200   <b>Soft:</b> 0-1,400
<b>Impacts Per Minute (IPM)</b> Impak Per Minit 冲击数	<b>Hard:</b> 0-2,700   <b>Medium:</b> 0-2,200   <b>Soft:</b> 0-1,400
<b>Max Fastening Torque</b> Maksimum Tenaga Pemutaran Pengancing 最快扭力	40N-m (355in.lbs.)
<b>Dimensions (L x W x H)</b> Dimensi 体积	136x79x240mm (5-3/8"x3-1/8"x9-1/2")
<b>Net Weight</b> Berat Bersih 淨重	1.3 - 1.6kg (2.8 - 3.5lbs)
<b>Work Amount (approx.)</b> Jumlah Kerja 工作量	750 pcs with BL1850B Wood screw ø4.3 x 65mm

Model No. 型号	No Load Speed (rpm) Kelajuan Tanpa Beban 回转数	Impacts Per Minute (IPM) Impak Per Minit 冲击数	Electronic Speed Kelajuan Elektronik 电子速度	Max. Fastening Torque (N.m) Maksimum Tenaga Pemutaran Pengancing 最快扭转	Overall Length (mm) Panjang Keseluruhan 总长度	Net Weight Berat Bersih 淨重	BL MOTOR	XPT
<b>Cordless Impact Driver</b>								
DTD171	0 - 3,600/3,200/2,100/1,100/1,800/ 3,600/2,900/3,600	0 - 3,800/3,600/2,600/1,100/3,800/ 3,800/NA/2,600	4	180	116	1.2kg (2.7lbs)	●	●
DTD170	0 - 3,600/3,200/2,100/1,100/3,600	0 - 3,800/3,600/2,600/1,100/2,600	4	175	117	1.2kg (2.7lbs)	●	●
DTD154	0 - 3,600/0 - 2,100/0 - 1,100	0 - 3,800/0 - 2,600/0 - 1,100	3	175	117	1.3kg (2.7lbs)	●	●
DTD153	0 - 3,400	0 - 3,600	-	170	126	1.3kg (2.8lbs)	●	●
DTD149	0 - 2,500	0 - 3,200	-	165	135	1.3 kg (2.8lbs)	●	●
DTD152	0 - 2,900	0 - 3,500	-	165	137	1.3kg (2.8lbs)	●	●
DTD156	0 - 2,500	0 - 3,000	-	155	143	1.3kg (2.9lbs)	●	●
DTD155	0 - 3,000/0 - 1,300	0 - 3,900/0 - 1,600	2	140	135	1.2kg (2.6lbs)	●	●
<b>Cordless 4 Mode Impact Driver (Impact-driver mode)</b>								
DTP141	0-2,700/ 0-2,200/ 0-1,300	0-3,200/0-2,400/ 0-1,200	3	150	171	1.5kg (3.4lbs)	●	●
<b>Cordless Oil-Pulse Drive</b>								
DTS141	0-3,200/ 0-2,000/ 0-1,200	0-2,700/0-2,200/ 0-1,400	3	40	136	1.3kg (2.8lbs)	●	●

**DTL061Z**  
RM 1,127

**Cordless Angle Impact Driver**  
Pemutar Skru Impak Sudut  
Tanpa Kord  
充电式角冲击螺丝起子机



- 360 degrees rotatable head enables operation from optimum angle

Standard Equipment: Belt Clip

- Z: Without Charger & Battery



<b>Capacity</b> Kapasiti 能力	<b>Machine Screw:</b> M4 - M8 (5/32" - 5/16") <b>Standard Bolt:</b> M4 - M12 (5/32" - 1/2") <b>High Tensile Bolt:</b> M4 - M8 (5/32" - 5/16") <b>Coarse Thread (in length):</b> 22 - 75mm (7/8" - 2-31/32") 6.35mm (1/4")
<b>Hex Shank</b> Batang Heksagon 六角柄	
<b>No Load Speed (RPM)</b> Kelajuan Tanpa Beban 回转数	0 - 2,000
<b>Impacts Per Minute (IPM)</b> Impak Per Minit 冲击数	0 - 3,000
<b>Max Fastening Torque</b> Maksimum Tenaga Pemutaran Pengancing 最快扭力	60N-m (530in.lbs.)
<b>Dimensions (L x W x H)</b> Dimensi 体积	387x78x116mm (15-1/4"x3-1/16"x4-9/16")
<b>Net Weight</b> Berat Bersih 淨重	1.4 - 2.0kg (3.1 - 4.3lbs)
<b>Work Amount (approx.)</b> Jumlah Kerja 工作量	350 pcs with BL1850B Wood Screw 4.2 x 65mm

\* All list price shown are for reference only (exclude SST).

\* Semua harga yang ditunjukkan adalah untuk rujukan sahaja (tidak termasuk SST). 所有显示的建议零售价仅供参考 (不包括SST)。

Cordless  
Target Applications

LED Flashlight  
Lampu Suluh LED  
LED燈

Vacuum Cleaner  
Pembersih Vakuum  
吸尘器

Drilling / Fastening  
Guauli / Pengancing  
钻孔 / 紧固

Impact Drilling / Demolition  
Guauli / Penekas  
冲击钻孔 / 破拆施工

Cutting  
Pemotong  
切割

Grinding / Sanding  
Pengkilan / Poles  
研磨 / 打磨

Sanding  
Guauli  
打磨

Planing / Routing  
Pengkilan / Tunggam  
刨削 / 压线

Others  
Lain-lain  
其他

Outdoor Power Equipment  
Alatan Kuasa Luar  
户外动力工具

Thakita  
18V



Li-ion Ah 6.0 5.0 4.0 3.0 2.0 1.5

Cordless Target Kord 无绳式  
LED Flashlight Lampu Suluh LED LED 照明灯  
Vacuum Cleaner Pembersih Vakuum 吸尘器  
Drilling / Fastening Daurul / Pengekat 钻孔 / 紧固  
Impact Drilling / Demolition Daurul / Penembak 起工钻孔 / 拆屋加工  
Cutting Pemotong 切割  
Grinding / Sanding Pengisar / Poles 磨削 / 打磨  
Sawing Gergaji 电锯  
Planing / Routing Pengisar / Tangkapan 刨削 / 磨床  
Others Lain-lain 其他  
Outdoor Power Equipment Alatan Kerja Luar 园林-户外

**DDA351Z** 10mm (3/8")  
RM 1,108

440

**Cordless Angle Drill**  
Gerudi Sudut Tanpa Kord  
充电式角向电钻



- Original 4-pole motor for power, lightweight and compact size



Standard Equipment: Side Grip

- Z: Without Charger & Battery



<b>Capacity</b> Kapasiti 能力	Steel: 10mm (3/8") Wood: 25mm (1")
<b>No Load Speed (RPM)</b> Kelajuan Tanpa Beban 回转数	0-1,800
<b>Dimensions (L x W x H)</b> Dimensi 体积	326x79x115mm (12-7/8"x3-1/8"x4-1/2")
<b>Net weight</b> Berat Bersih 淨重	1.6 - 1.9kg (4.2 - 3.5lbs)
<b>Work Amount (approx.)</b> Jumlah Kerja 工作量	1000 pcs with BL1850B Wood Screw ø5.1 x 38mm

**DFS452Z**  
RM 1,427

**Cordless Screwdriver**  
Pemutar Skru Tanpa Kord  
充电式螺丝起子机



- Push Drive Technology for Quieter Operation; Minimizes Power Consumption



Standard Equipment: Phillips Bit, Magnetic Bit Holder, Belt Clip

- Z: Without Charger & Battery



<b>Capacity</b> Kapasiti 能力	Self-Drilling Screw: 6mm (1/4") Drywall Screw: 5mm (3/16") 6.35mm (1/4")
<b>Driving Shank (Hex)</b> Hex Memandu Aci 六角驱动轴	
<b>No Load Speed (RPM)</b> Kelajuan Tanpa Beban 回转数	0 - 4,000
<b>Dimensions (L x W x H)</b> Dimensi 体积	251x79x259mm (10"x3-1/8"x11-1/4")
<b>Net weight</b> Berat Bersih 淨重	1.5 - 1.8kg (3.2 - 3.9lbs)
<b>Work Amount (approx.)</b> Jumlah Kerja 工作量	2325 pcs with BL1850B Wood Screw 1.0 x 32mm

**DFS250RTE** | **DFS250RFE** | **DFS250Z**  
RM 2,553 | RM 2,243 | RM 1,270

**Cordless Screwdriver**  
Pemutar Skru Tanpa Kord  
充电式螺丝起子机



- Ultra-high efficiency comparable to AC screwdrivers



Standard Equipment: Phillips Bit, Magnetic Bit Holder, Belt Clip

- RTE: 1x Rapid Charger, 2x 5.0Ah Battery
- RFE: 1x Rapid Charger, 2x 3.0Ah Battery
- Z: Without Charger, Battery & Carrying Case

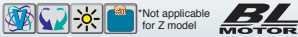

<b>Capacity</b> Kapasiti 能力	Coarse Thread: 4.5 x 90mm (3/16" x 3-1/2") Self-Drilling Screw: 6mm (1/4") Drywall Screw: 5mm (3/16") 6.35mm (1/4")
<b>Driving Shank (Hex)</b> Hex Memandu Aci 六角驱动轴	
<b>No Load Speed (RPM)</b> Kelajuan Tanpa Beban 回转数	0 - 2,500
<b>Dimensions (L x W x H)</b> Dimensi 体积	259x79x259mm (10-1/4"x3-1/8"x10-1/4")
<b>Net weight</b> Berat Bersih 淨重	1.5 - 1.9kg (3.4 - 4.1lbs)
<b>Work Amount (approx.)</b> Jumlah Kerja 工作量	1091 pcs with BL1850B Wood Screw 8" x 1" (Pine Wood)

**DFS251RTE** | **DFS251RFE** | **DFS251Z**  
RM 2,553 | RM 2,243 | RM 1,270

**Cordless Screwdriver**  
Pemutar Skru Tanpa Kord  
充电式螺丝起子机



- High torque ideal for fastening self-drilling screw



Standard Equipment: Magnetic Socket Bit, Belt Clip

- RTE: 1x Rapid Charger, 2x 5.0Ah Battery
- RFE: 1x Rapid Charger, 2x 3.0Ah Battery
- Z: Without Charger, Battery & Carrying Case



<b>Capacity</b> Kapasiti 能力	Self-Drilling Screw: 6mm (1/4") Drywall Screw: 5mm (3/16") Hex Socket Screw: 6mm (1/4")
<b>Driving Shank (Hex)</b> Hex Memandu Aci 六角驱动轴	6.35mm (1/4")
<b>No Load Speed (RPM)</b> Kelajuan Tanpa Beban 回转数	0 - 2,500
<b>Dimensions (L x W x H)</b> Dimensi 体积	237x79x259mm (9-3/8"x3-1/8"x11-1/4")
<b>Net weight</b> Berat Bersih 淨重	1.5 - 1.8kg (3.2 - 3.9lbs)
<b>Work Amount (approx.)</b> Jumlah Kerja 工作量	1091 pcs with BL1850B Wood Screw 8" x 1" (Pine Wood)

**DFR550Z**  
RM 1,452

440

**Cordless Auto Feed Screwdriver**  
Pemutar Skru Suapan Auto Tanpa Kord  
充电式自动螺丝起子机



- Ideal for drywall and subfloors



Standard Equipment: Phillips Bit x3

- Z: Without Charger & Battery



<b>Screw Strip</b> Kapasiti 能力	4 x 25 - 55mm (5/32" x 1" - 2-3/16")
<b>Driving Shank (Hex)</b> Hex Memandu Aci 六角驱动轴	6.35mm (1/4")
<b>No Load Speed (RPM)</b> Kelajuan Tanpa Beban 回转数	4,000
<b>Dimensions (L x W x H)</b> Dimensi 体积	424x80x238mm (16-3/4"x3-1/8"x9-3/8")
<b>Net weight</b> Berat Bersih 淨重	2.1 - 3.1kg (4.6 - 6.9lbs)
<b>Work Amount (approx.)</b> Jumlah Kerja 工作量	1166 pcs with BL1850B Wood Screw 35mm (1-3/8) (plasterboard into Douglas-fir timber)

\* All list price shown are for reference only (exclude SST).

\* Semua harga yang ditunjukkan adalah untuk rujukan sahaja (tidak termasuk SST). 所有显示的建议零售价仅供参考 (不包括SST)。





# BRUSHLESS MOTOR

Motor tanpa berus 无碳刷马达

- ▶ Maintenance-free due to no brush
- ▶ Life time work amount of a battery is increased
- ▶ Durable against long continuous operation
- ▶ More work amount on a single full battery charge

免却更换碳刷的高频工序，保养轻松简单  
采用BL无碳刷马达的工具没有因摩擦热导致的能量流失，  
所以每次充电后的连续工作时间更长



# BRUSHED MOTOR

Motor dengan berus 有刷马达

- ▶ High power-to-weight ratio obtained by employing 4-pole motor

Berkuasa tinggi dengan motor 4-pole  
采用4极马达，高功率



## Max Fastening Torque

Maksimum Tenaga Pemutaran Pengancing 最大扭矩



\* All list price shown are for reference only (exclude SST).

\* Semua harga yang ditunjukkan adalah untuk rujukan sahaja (tidak termasuk SST). 所有显示的建议零售价仅供参考 (不包括SST)。

Cordless  
Tanpa Kord / 无绳

LED Flashlight  
Lampu Suhu LED  
LED手电筒

Vacuum Cleaner  
Pembersih Vakuum  
吸尘器

Drilling / Fastening  
Ganda / Pengancu  
钻孔 / 紧固

Impact Drilling / Demolition  
Ganda / Persekit  
冲击钻孔 / 拆除施工

Cutting  
Pemotong  
切割

Grinding / Sanding  
Pengancu / Pencil  
研磨 / 砂磨

Sawing  
Gergaji  
锯切

Planing / Routing  
Pengancu / Tangan  
刨平 / 压边

Others  
Lain-lain  
其他

Outdoor Power Equipment  
Alatan Kuat Luar  
园机 / 户外

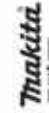



Li-ion Ah 6.0 | 5.0 | 4.0 | 3.0 | 2.0 | 1.5

**DTW1001RTJ** RM 3,542 | **DTW1001RMJ** RM 3,397 | **DTW1001RFJ** RM 3,232 | **DTW1001Z** 19mm (3/4") RM 2,257

**Cordless Impact Wrench**  
Perengkuh Impak Tanpa Kord  
充电式冲击套筒扳手



VIDEO CLIP  
Models and specs may vary by country



• Makita's Most Powerful Impact Wrench

Standard Equipment: Hook

- RTJ: 1x Rapid Charger, 2x 5.0Ah Battery, 1x Makpac Connector Box
- RMJ: 1x Rapid Charger, 2x 4.0Ah Battery, 1x Makpac Connector Box
- RFJ: 1x Rapid Charger, 2x 3.0Ah Battery, 1x Makpac Connector Box
- Z: Without Charger, Battery & Carrying Case

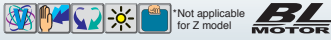

\*Not applicable for Z model



**DTW1002RTJ** RM 3,457 | **DTW1002RMJ** RM 3,312 | **DTW1002RFJ** RM 3,147 | **DTW1002Z** 12.7mm (1/2") RM 2,172

**Cordless Impact Wrench**  
Perengkuh Impak Tanpa Kord  
充电式冲击套筒扳手



• Efficient impact system (Max 2,200 IPM) with less vibration

Standard Equipment: Hook

- RTJ: 1x Rapid Charger, 2x 5.0Ah Battery, 1x Makpac Connector Box
- RMJ: 1x Rapid Charger, 2x 4.0Ah Battery, 1x Makpac Connector Box
- RFJ: 1x Rapid Charger, 2x 3.0Ah Battery, 1x Makpac Connector Box
- Z: Without Charger, Battery & Carrying Case

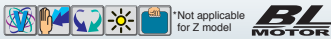

\*Not applicable for Z model



**DTW800RMJ** RM 3,338 | **DTW800RFJ** RM 3,173 | **DTW800Z** 11.2mm (7/16") RM 2,198

**Cordless Impact Wrench**  
Perengkuh Impak Tanpa Kord  
充电式冲击套筒扳手



• Extremely high power 800N-m (590ft.lbs.) way ahead of competitors

Standard Equipment: Hook

- RMJ: 1x Rapid Charger, 2x 4.0Ah Battery, 1x Makpac Connector Box
- RFJ: 1x Rapid Charger, 2x 3.0Ah Battery, 1x Makpac Connector Box
- Z: Without Charger, Battery & Carrying Case

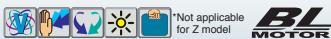

\*Not applicable for Z model



**DTW450RME** RM 2,353 | **DTW450RFE** RM 2,190 | **DTW450Z** 12.7mm (1/2") RM 1,215 441

**Cordless Impact Wrench**  
Perengkuh Impak Tanpa Kord  
充电式冲击套筒扳手



• Compact and lightweight design provide superior balance and control

Standard Equipment: Hook

- RME: 1x Rapid Charger, 2x 4.0Ah Battery
- RFE: 1x Rapid Charger, 2x 3.0Ah Battery
- Z: Without Charger, Battery & Carrying Case



\*Not applicable for Z model



**DTW285RME** RM 2,457 | **DTW285RFE** RM 2,293 | **DTW285Z** 12.7mm (1/2") RM 1,318

**Cordless Impact Wrench**  
Perengkuh Impak Tanpa Kord  
充电式冲击套筒扳手



Reverse Rotation Auto Stop Mode  
Mod auto berhenti untuk putaran terbalik 反转自动停止模式



• BL motor delivers 280N-m of max torque

Standard Equipment: Belt Clip

- RME: 1x Rapid Charger, 2x 4.0Ah Battery
- RFE: 1x Rapid Charger, 2x 3.0Ah Battery
- Z: Without Charger, Battery & Carrying Case

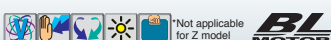

\*Not applicable for Z model



<b>Fastening Capacities</b> Kapasiti 能力	Standard Bolt: M12 - M30 (1/2" - 1-1/4") High Tensile Bolt: M10 - M24 (3/8" - 1") 19mm (3/4")
<b>Square Drive</b> Skrus Persegi 方形螺栓	
<b>No Load Speed (RPM)</b> Kelajuan Tanpa Beban 回转数	Hard: 0 - 1,800   Medium: 0 - 1,000   Soft: 0 - 900
<b>Impacts Per Minute (IPM)</b> Impak Per Minit 冲击数	Hard: 0 - 2,200   Medium: 0 - 2,000   Soft: 0 - 1,800
<b>Max Fastening Torque</b> Pemutaran Tenaga Maksimum 最大扭矩	1,050N-m (780ft.lbs.)
<b>Dimensions (L x W x H)</b> Dimensi 体积	229x91x289mm (9"x3-5/8"x11-3/8")
<b>Net Weight</b> Berat Bersih 淨重	3.4 - 3.7kg (7.5 - 8.2lbs)
<b>Work Amount (approx.)</b> Jumlah Kerja 工作量	185 pcs with BL1850B Bolts M20

<b>Fastening Capacities</b> Kapasiti 能力	Standard Bolt: M12 - M30 (1/2" - 1-1/4") High Tensile Bolt: M10 - M24 (3/8" - 1") 12.7mm (1/2")
<b>Square Drive</b> Skrus Persegi 方形螺栓	
<b>No Load Speed (RPM)</b> Kelajuan Tanpa Beban 回转数	Hard: 0 - 1,800   Medium: 0 - 1,000   Soft: 0 - 900
<b>Impacts Per Minute (IPM)</b> Impak Per Minit 冲击数	Hard: 0 - 2,200   Medium: 0 - 2,000   Soft: 0 - 1,800
<b>Max Fastening Torque</b> Pemutaran Tenaga Maksimum 最大扭矩	1,000N-m (740ft.lbs.)
<b>Dimensions (L x W x H)</b> Dimensi 体积	229x91x289mm (9"x3-5/8"x11-3/8")
<b>Net Weight</b> Berat Bersih 淨重	3.3 - 3.6kg (7.3 - 8.0lbs)
<b>Work Amount (approx.)</b> Jumlah Kerja 工作量	185 pcs with BL1850B Bolts M20

<b>Fastening Capacities</b> Kapasiti 能力	Standard Bolt: M12 - M24 (1/2" - 1") High Tensile Bolt: M10 - M22 (3/8" - 7/8") 11.1mm (7/16")
<b>Hex Shank</b> Skrus Persegi 方形螺栓	
<b>No Load Speed (RPM)</b> Kelajuan Tanpa Beban 回转数	Hard: 0 - 1,800   Medium: 0 - 1,000   Soft: 0 - 900
<b>Impacts Per Minute (IPM)</b> Impak Per Minit 冲击数	Hard: 0 - 2,200   Medium: 0 - 2,000   Soft: 0 - 1,800
<b>Max Fastening Torque</b> Pemutaran Tenaga Maksimum 最大扭矩	800N-m (590ft.lbs.)
<b>Dimensions (L x W x H)</b> Dimensi 体积	229x91x303mm (9"x3-5/8"x11-7/8")
<b>Net Weight</b> Berat Bersih 淨重	3.4 - 3.7kg (8.2 - 7.5lbs)
<b>Work Amount (approx.)</b> Jumlah Kerja 工作量	27 holes with BL1850B Auger Drill ø13/16" (Drill 300mm Douglas-fir)

<b>Fastening Capacities</b> Kapasiti 能力	Standard Bolt: M12 - M22 (1/2" - 7/8") High Tensile Bolt: M12 - M16 (1/2" - 5/8") 12.7mm (1/2")
<b>Square Drive</b> Skrus Persegi 方形螺栓	
<b>No Load Speed (RPM)</b> Kelajuan Tanpa Beban 回转数	1,600
<b>Impacts Per Minute (IPM)</b> Impak Per Minit 冲击数	2,200
<b>Max Fastening Torque</b> Pemutaran Tenaga Maksimum 最大扭矩	440N-m (325 ft.lbs.)
<b>Dimensions (L x W x H)</b> Dimensi 体积	266x82x290mm (10-1/2"x3-1/4"x11-3/8")
<b>Net Weight</b> Berat Bersih 淨重	3.1 - 3.4kg (7.6 - 6.9lbs)
<b>Work Amount (approx.)</b> Jumlah Kerja 工作量	120 pcs with BL1850B Bolts M16

<b>Fastening Capacities</b> Kapasiti 能力	Standard Bolt: M10 - M20 (3/8" - 3/4") High Tensile Bolt: M10 - M16 (3/8" - 5/8") 12.7mm (1/2")
<b>Square Drive</b> Skrus Persegi 方形螺栓	
<b>No Load Speed (RPM)</b> Kelajuan Tanpa Beban 回转数	Hard: 0 - 2,800   Medium: 0 - 2,100   Soft: 0 - 1,600
<b>Impacts Per Minute (IPM)</b> Impak Per Minit 冲击数	Hard: 0 - 3,500   Medium: 0 - 2,600   Soft: 0 - 1,800
<b>Max Fastening Torque</b> Pemutaran Tenaga Maksimum 最大扭矩	280N-m (210ft.lbs.)
<b>Dimensions (L x W x H)</b> Dimensi 体积	147x79x249mm (5-3/4"x3-1/8"x9-3/4")
<b>Net Weight</b> Berat Bersih 淨重	1.5 - 1.8kg (3.2 - 3.9lbs)
<b>Work Amount (approx.)</b> Jumlah Kerja 工作量	275 pcs with BL1850B High Tensile Bolt M16

\* All list price shown are for reference only (exclude SST).

\* Semua harga yang ditunjukkan adalah untuk rujukan sahaja (tidak termasuk SST). 所有显示的建议零售价仅供参考 (不包括SST)。

Cordless Target Kord 无绳  
LED Flashlight Lampu Suluh LED LED 手电筒  
Vacuum Cleaner Pemilauhi VAKUM 吸尘器  
Drilling / Fastening Druil / Pengikat 钻孔 / 紧固  
Impact Drilling / Demolition Druil Impak / Penanggal 冲击钻孔 / 拆除加工  
Cutting Pemotong 切割  
Grinding / Sanding Pengisar / Pasah 磨削 / 砂磨  
Sawing Gergaji 电锯  
Planing / Routing Pengisar / Tampat 刨削 / 雕刻  
Others Lain-lain 其他  
Outdoor Power Equipment Alatan Kerja Luar 户外动力设备





Li-ion Ah 6.0 5.0 4.0 3.0 2.0 1.5

**DTW251RME** DTW251RFE DTW251Z 12.7mm (1/2") 448mm

RM 2,110 RM 1,947 RM 972

**Cordless Impact Wrench**  
Perengkuh Impak Tanpa Kord  
充电式冲击套筒扳手



- High power, compact and lightweight 4-pole motor

Standard Equipment: Belt Clip

- RME: 1x Rapid Charger, 2x 4.0Ah Battery
- RFE: 1x Rapid Charger, 2x 3.0Ah Battery
- Z: Without Charger, Battery & Carrying Case



**DTW181RFE** DTW181Z 12.7mm (1/2")

RM 1,757 RM 780

**Cordless Impact Wrench**  
Perengkuh Impak Tanpa Kord  
充电式冲击套筒扳手



- Ideal for working in tight spaces

Standard Equipment: Belt Clip

- RFE: 1x Rapid Charger, 2x 3.0Ah Battery
- Z: Without Charger, Battery & Carrying Case



**DTW180Z** 9.5mm (3/8")

RM 780

**Cordless Impact Wrench**  
Perengkuh Impak Tanpa Kord  
充电式冲击套筒扳手



- Ideal for working in tight spaces

Standard Equipment: Belt Clip

- Z: Without Charger & Battery



**DTW190RME** DTW190RFE DTW190Z 12.7mm (1/2")

RM 1,713 RM 1,550 RM 573

**Cordless Impact Wrench**  
Perengkuh Impak Tanpa Kord  
充电式冲击套筒扳手



- 190N-m (140ft.lbs.) of Max torque optimal for scaffold building

- RME: 1x Rapid Charger, 2x 4.0Ah Battery
- RFE: 1x Rapid Charger, 2x 3.0Ah Battery
- Z: Without Charger, Battery & Carrying Case



<b>Fastening Capacities</b> Kapasiti 能力	Standard Bolt: M10 - M16 (3/8" - 5/8") High Tensile Bolt: M10 - M14 (3/8" - 9/16") 12.7mm (1/2")
<b>Square Drive</b> Skru Persegi 方形螺柱	
<b>No Load Speed (RPM)</b> Kelajuan Tanpa Beban 回转数	0 - 2,100
<b>Impacts Per Minute (IPM)</b> Impak Per Minit 冲击数	0 - 3,200
<b>Max Fastening Torque</b> Pemutaran Tenaga Maksimum 最大扭矩	230N-m (170ft.lbs.)
<b>Dimensions (L x W x H)</b> Dimensi 体积	165x79x234mm (6-1/2"x3-1/8"x9-1/4")
<b>Net Weight</b> Berat Bersih 净重	1.5 - 1.8kg (3.2 - 3.9lbs)
<b>Work Amount (approx.)</b> Jumlah Kerja 工作量	250 pcs with BL1850B Bolt M14

<b>Fastening Capacities</b> Kapasiti 能力	Standard Bolt: M8 - M16 (5/16" - 5/8") High Strength Bolt: M6 - M12 (1/4" - 1/2") 12.7 mm (1/2")
<b>Square Drive</b> Skru Persegi 方形螺柱	
<b>No Load Speed (RPM)</b> Kelajuan Tanpa Beban 回转数	Hard: 0 - 2,400   Soft: 0 - 1,300
<b>Impacts Per Minute (IPM)</b> Impak Per Minit 冲击数	Hard: 0 - 3,600   Soft: 0 - 2,000
<b>Max Fastening Torque</b> Pemutaran Tenaga Maksimum 最大扭矩	210N-m (155ft.lbs.)
<b>Dimensions (L x W x H)</b> Dimensi 体积	151x79x235mm (5-15/16"x3-1/8"x9-1/4")
<b>Net Weight</b> Berat Bersih 净重	1.2 - 1.5kg (2.7 - 3.4lbs.)

<b>Fastening Capacities</b> Kapasiti 能力	Standard Bolt: M8 - M16 (5/16" - 5/8") High Tensile Bolt: M6 - M12 (1/4" - 1/2") 9.5 mm (3/8")
<b>Square Drive</b> Skru Persegi 方形螺柱	
<b>No Load Speed (RPM)</b> Kelajuan Tanpa Beban 回转数	Hard: 0 - 2,400   Soft: 0 - 1,300
<b>Impacts Per Minute (IPM)</b> Impak Per Minit 冲击数	Hard: 0 - 3,600   Soft: 0 - 2,000
<b>Max Fastening Torque</b> Pemutaran Tenaga Maksimum 最大扭矩	180N-m (130ft.lbs.)
<b>Dimensions (L x W x H)</b> Dimensi 体积	144x79x235mm (5-5/8"x3-1/8"x9-1/4")
<b>Net Weight</b> Berat Bersih 净重	1.2 - 1.5kg (2.7 - 3.4lbs.)

<b>Fastening Capacities</b> Kapasiti 能力	Standard Bolt: M8 - M16 (5/16" - 5/8") High Tensile Bolt: M8 - M12 (5/16" - 1/2") 12.7mm (1/2")
<b>Square Drive</b> Skru Persegi 方形螺柱	
<b>No Load Speed (RPM)</b> Kelajuan Tanpa Beban 回转数	0 - 2,300
<b>Impacts Per Minute (IPM)</b> Impak Per Minit 冲击数	0 - 3,000
<b>Max Fastening Torque</b> Pemutaran Tenaga Maksimum 最大扭矩	190N-m (140ft.lbs.)
<b>Overall Length</b> Dimensi 体积	176mm (6-15/16")
<b>Net Weight</b> Berat Bersih 净重	1.4 - 1.8kg (3.2 - 3.9lbs)

Model No. 型号	Square Drive Skru Pemacu Persegi 方形传动螺柱	No Load Speed (rpm) Kelajuan Tanpa Beban 回转数	Impacts Per Minute (IPM) Impak Per Minit 冲击数	Max. Fastening Torque (N.m) Maksimum Tenaga Pemutaran Pengancing 最大扭矩	Overall Length (mm) Panjang Keseluruhan 总长度	Net Weight Berat Bersih 净重	BL MOTOR	XPT
<b>Cordless Impact Wrench</b>								
DTW1001	19mm (3/4")	0-1,800 / 0-1,000 / 0-900	0 - 2,200 / 0 - 2,000 / 0 - 1,800	1,050 (780ft.lbs.)	229	3.4kg (7.5lbs)	●	
DTW1002	12.7mm (1/2")	0-1,800 / 0-1,000 / 0-900	0 - 2,200 / 0 - 2,000 / 0 - 1,800	1,000 (740ft.lbs.)	229	3.3kg (7.3lbs)	●	
DTW800	11.2mm (7/16") Hex.	0-1,800 / 0-1,000 / 0-900	0 - 2,200 / 0 - 2,000 / 0 - 1,800	800 (590ft.lbs.)	229	3.4kg (8.2lbs)	●	
DTW450	12.7mm (1/2")	1,600	2,200	440 (325ft.lbs.)	266	3.1kg (7.6lbs)		
DTW285	12.7mm (1/2")	0-2,800 / 0-2,100 / 1,600	0 - 3,500 / 0 - 2,600 / 0 - 1,800	280 (210ft.lbs.)	147	1.5kg (3.2lbs)	●	●
DTW251	12.7mm (1/2")	0-2,100	0 - 3,200	230 (170ft.lbs.)	165	1.5kg (3.2lbs)		
DTW181	12.7mm (1/2")	0-2,400 / 0-1,300	0 - 3,600 / 0-2,000	210 (155ft.lbs.)	151	1.2kg (2.7lbs)	●	●
DTW180	9.5mm (3/8")	0-2,400 / 0-1,300	0 - 3,600 / 0-2,000	180 (130ft.lbs.)	144	1.2kg (2.7lbs)	●	●
DTW190	12.7mm (1/2")	0-2,300	0 - 3,000	190 (140ft.lbs.)	176	1.4kg (3.2lbs)		

\* All list price shown are for reference only (exclude SST).

\* Semua harga yang ditunjukkan adalah untuk rujukan sahaja (tidak termasuk SST). 所有显示的建议零售价仅供参考 (不包括SST)。

Cordless  
Targeted Jobs

LED Flashlight  
Lampu Suli LED  
LED照明灯

Vacuum Cleaner  
Pembersih Vakuum  
吸尘器

Drilling / Fastening  
Ganub / Pasang  
钻孔 / 紧固

Impact Drilling / Demolition  
Ganub / Pasang  
冲击钻孔 / 拆除

Cutting  
Panasir  
切割

Grinding / Sanding  
Pengisar / Pasir  
打磨 / 砂磨

Sawing  
Gajir  
锯切

Planing / Routing  
Pengaliran / Tangan  
刨削 / 雕刻

Others  
Lain-lain  
其他

Outdoor Power Equipment  
Alatan Kuat Luar  
户外动力工具





Li-ion Ah 6.0 | 5.0 | 4.0 | 3.0 | 2.0 | 1.5

**DTL063Z** 9.5mm (3/8")  
RM 1,218

**Cordless Angle Impact Wrench**  
Perengkuh Impak Sudut Tanpa Kord  
充电式角向冲击套筒扳手



- Compact angle head for easy access to bolts in tight places



Standard Equipment: Belt Clip

- Z: Without Charger & Battery



<b>Fastening Capacities</b> Kapasiti 能力	<b>Standard Bolt:</b> M4 - M12 (5/32" - 1/2")
<b>Square Drive</b> Skrus Persegi 方形螺柱	<b>High Tensile Bolt:</b> M4 - M8 (5/32" - 5/16") 9.5mm (3/8")
<b>No Load Speed (RPM)</b> Kelajuan Tanpa Beban 回转数	0 - 2,000
<b>Impacts Per Minute (IPM)</b> Impak Per Minit 冲击数	0 - 3,000
<b>Max Fastening Torque</b> Pemutaran Tenaga Maksimum 最大扭矩	60N-m (N/A ft.lbs.)
<b>Dimensions (L x W x H)</b> Dimensi 体积	387x78x116mm (15-1/4"x3-1/16"x4-9/16")
<b>Net Weight</b> Berat Bersih 淨重	1.4 - 2.0kg (3.1 - 4.3lbs)

**DHR242RTE** | **DHR242RME** | **DHR242RFE** | **DHR242Z** 24mm (15/16")  
RM 2,745 | RM 2,600 | RM 2,437 | RM 1,460

**Cordless Combination Hammer**  
Tukul Kombinasi Tanpa Kord  
充电式冲击电钻电锤



- 3-Mode operation; rotation only, hammering with rotation and hammering only

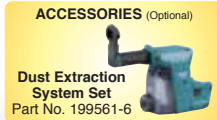

Standard Equipment: Depth Gauge, Side Grip

- RTE: 1x Rapid Charger, 2x 5.0Ah Battery
- RME: 1x Rapid Charger, 2x 4.0Ah Battery
- RFE: 1x Rapid Charger, 2x 3.0Ah Battery
- Z: Without Charger, Battery & Carrying Case



\*Not applicable for Z model



<b>Impact Energy</b> Kekuatan Impak 单次最大冲击力	2J
<b>Capacity</b> Kapasiti 能力	<b>Concrete:</b> 24mm (15/16")   <b>Steel:</b> 13mm (1/2")   <b>Wood:</b> 27mm (1-1/16")
<b>Impacts Per Minute (IPM)</b> Impak Per Minit 冲击数	0 - 4,700
<b>No Load Speed (RPM)</b> Kelajuan Tanpa Beban 回转数	0 - 950
<b>Dimensions (L x W x H)</b> Dimensi 体积	328x85x213mm (12-7/8"x3-3/8"x8-3/8")
<b>Net Weight</b> Berat Bersih 淨重	3.1 - 3.8kg (6.7 - 8.4lbs)
<b>Work Amount (approx.)</b> Jumlah Kerja 工作量	60 holes with BL1850B Masonry Drill ø10.5mm Concrete Depth 60mm

**DHR241RFE** | **DHR241Z** 20mm (13/16")  
RM 2,017 | RM 1,040

**Cordless Combination Hammer**  
Tukul Kombinasi Tanpa Kord  
充电式冲击电钻电锤



- 3-Mode operation; rotation only, hammering with rotation and hammering only



Standard Equipment: Depth Gauge, Side Grip

- RFE: 1x Rapid Charger, 2x 3.0Ah Battery
- Z: Without Charger, Battery & Carrying Case



\*Not applicable for Z model



<b>Impact Energy</b> Kekuatan Impak 单次最大冲击力	1.9J
<b>Capacity</b> Kapasiti 能力	<b>Concrete:</b> 20mm (13/16")   <b>Steel:</b> 13mm (1/2")   <b>Wood:</b> 26mm (1")
<b>Impacts Per Minute (IPM)</b> Impak Per Minit 冲击数	0 - 4,000
<b>No Load Speed (RPM)</b> Kelajuan Tanpa Beban 回转数	0 - 1,100
<b>Dimensions (L x W x H)</b> Dimensi 体积	417x84x219mm (16-3/8"x3-5/16"x8-5/8")
<b>Net Weight</b> Berat Bersih 淨重	3.2 - 4.0kg (7.1 - 8.8lbs)
<b>Work Amount (approx.)</b> Jumlah Kerja 工作量	133 holes with BL1850B Masonry drill ø16.5mm Concrete Depth 40mm

**DHR202RME** | **DHR202RFE** | **DHR202Z** 20mm (13/16")  
RM 2,235 | RM 2,072 | RM 1,095

**Cordless Combination Hammer**  
Tukul Kombinasi Tanpa Kord  
充电式冲击电钻电锤



- 3-Mode operation; rotation only, hammering with rotation and hammering only



Standard Equipment: Depth Gauge, Side Grip

- RME: 1x Rapid Charger, 2x 4.0Ah Battery
- RFE: 1x Rapid Charger, 2x 3.0Ah Battery
- Z: Without Charger, Battery & Carrying Case



\*Not applicable for Z model

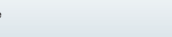

<b>Capacity</b> Kapasiti 能力	<b>Concrete:</b> 20mm (13/16")   <b>Steel:</b> 13mm (1/2")   <b>Wood:</b> 26mm (1")
<b>Impacts Per Minute (IPM)</b> Impak Per Minit 冲击数	0 - 4,000
<b>No Load Speed (RPM)</b> Kelajuan Tanpa Beban 回转数	0 - 1,100
<b>Dimensions (L x W x H)</b> Dimensi 体积	358x84x259mm (14-1/8"x3-5/16"x10-1/4")
<b>Net Weight</b> Berat Bersih 淨重	3.2 - 4.0kg (7.1 - 8.8lbs)
<b>Work Amount (approx.)</b> Jumlah Kerja 工作量	130 holes with BL1850B Masonry drill ø6.5mm Concrete Depth 60mm

**DHR182ZWJ** 18mm (11/16")  
RM 1,957

**Cordless Combination Hammer**  
Tukul Kombinasi Tanpa Kord  
充电式冲击电钻电锤



- Auto-start Wireless System (AWS) connects to vacuum cleaner with Bluetooth



Standard Equipment: Side Grip, Depth Gauge

- ZWJ: Without Charger, Battery, Come with 1x Dust Extraction System Set, 1x Makpac Connector Box



\*Not applicable for Z model



<b>Impact Energy</b> Kekuatan Impak 单次最大冲击力	EPTA-Procedure 05/2009: 1.7J Our experimental conditions: 1.6J
<b>Capacity</b> Kapasiti 能力	<b>Concrete:</b> 18mm (11/16")   <b>Core Bit:</b> 35mm (1-3/8")   <b>Diamond Core Bit (Dry Type):</b> 32mm (1-1/4")   <b>Steel:</b> 13mm (1/2")   <b>Wood:</b> 24mm (15/16")
<b>Impacts Per Minute (IPM)</b> Impak Per Minit 冲击数	0 - 5,000
<b>No Load Speed (RPM)</b> Kelajuan Tanpa Beban 回转数	0 - 1,350
<b>Max Output</b> Keluaran Maksima 最大输出	450W
<b>Dimensions (L x W x H)</b> Dimensi 体积	301x82x285mm (11-7/8"x3-1/4"x11-1/4")
<b>Net Weight</b> Berat Bersih 淨重	2.4 - 3.2kg (5.3 - 7.0lbs.)

\* All list price shown are for reference only (exclude SST).

\* Semua harga yang ditunjukkan adalah untuk rujukan sahaja (tidak termasuk SST). 所有显示的建议零售价仅供参考 (不包括SST)。

Cordless Target Kord 无绳式  
LED Flashlight Lampu Suluh LED LED 照明灯  
Vacuum Cleaner Pemilauhi Vakuum 吸尘器  
Drilling / Fastening Druai / Pengikat 钻孔 / 紧固  
Impact Drilling / Demolition Druai / Penembok 起工钻孔 / 拆墙加工  
Cutting Pemotong 切割  
Grinding / Sanding Pengisar / Pasir 磨削 / 砂磨  
Sawing Gergaji 电锯  
Planing / Routing Pengisar / Tangkai 刨削 / 磨削  
Others Lain-lain 其他  
Outdoor Power Equipment Alatan Kerja Luar 户外户外



18V

LXT

Li-ion Ah 6.0 5.0 4.0 3.0 2.0 1.5

**DHR171RTE** RM 2,343 | **DHR171RFE** RM 2,035 | **DHR171Z** 17mm (11/16") RM 1,060

**Cordless Rotary Hammer**  
Tukul Putar Tanpa Kord  
充电式电锤



- 2-Mode operation; rotation only, or hammering with rotation only

Standard Equipment: Side Grip, Depth Gauge

- RTE: 1x Rapid Charger, 2x 5.0Ah Battery
- RFE: 1x Rapid Charger, 2x 3.0Ah Battery
- Z: Without Charger, Battery & Carrying Case



<b>Impact Energy</b> Kekuatan Impak 单次最大锤击力	EPTA-Procedure 05/2009: 1.2J Our experimental conditions: 1.1J
<b>Capacity</b> Kapasiti 能力	Concrete: 17mm (11/16")   Steel: 10mm (3/8")   Wood: 13mm (1/2")
<b>Impacts Per Minute (IPM)</b> Impak Per Minit 冲击数	0 - 4,800
<b>No Load Speed (RPM)</b> Kelajuan Tanpa Beban 回转数	0 - 680
<b>Dimensions (L x W x H)</b> Dimensi 体积	273x86x211mm (10-3/4"x3-3/8"x8-5/16")
<b>Net Weight</b> Berat Bersih 净重	2.1 - 2.8kg (4.6 - 6.2lbs)
<b>Work Amount (approx.)</b> Jumlah Kerja 工作量	220 holes with BL1850B Masonry Drill Ø6mm Concrete 40N/mm2 Depth 40mm

**DHR165RME** RM 2,130 | **DHR165RFE** RM 1,965 | **DHR165Z** 16mm (5/8") RM 990 **430mm**

**Cordless Rotary Hammer**  
Tukul Putar Tanpa Kord  
充电式电锤



- 2-Mode operation; rotation only, or hammering with rotation only

Standard Equipment: Depth Gauge, Side Grip

- RME: 1x Rapid Charger, 2x 4.0Ah Battery
- RFE: 1x Rapid Charger, 2x 3.0Ah Battery
- Z: Without Charger, Battery & Carrying Case



<b>Impact Energy</b> Kekuatan Impak 单次最大锤击力	1.3J
<b>Capacity</b> Kapasiti 能力	Concrete: 16mm (5/8")   Steel: 13mm (1/2")   Wood: 24mm (15/16")
<b>Impacts Per Minute (IPM)</b> Impak Per Minit 冲击数	0 - 5,300
<b>No Load Speed (RPM)</b> Kelajuan Tanpa Beban 回转数	0-1,600
<b>Dimensions (L x W x H)</b> Dimensi 体积	297x79x253mm (11-3/4"x3-1/8"x10")
<b>Net Weight</b> Berat Bersih 净重	2.3 - 3.0kg (5.0 - 6.6lbs)
<b>Work Amount (approx.)</b> Jumlah Kerja 工作量	225 holes with BL1850B Masonry drill ø6.5mm Concrete Depth 30mm

# Cordless Power Scraper

Pengikis Kuasa Tanpa Kord 充电式刮板



**Slide lever for trigger lock-on/ lock-off**  
Tuas gelongsor untuk kunci pencetus  
滑动杆用于扳机锁定



**Twin LED job light**  
Lampu kerja LED  
双LED工作灯



**Variable speed control by dial**  
Kawalan kelajuan 变速控制



**Vibration Level**  
Tahap Getaran 振动等级

**4.5m/s<sup>2</sup>**

**Impact Energy**  
Kekuatan Impak  
单次最大锤击力

**3.1J**

**DHK180Z** RM 3,400

**Cordless Power Scraper**  
Pengikis Kuasa Tanpa Kord  
充电式刮板



- High power & low vibration

Standard Equipment: Hook

- Z: Without Charger, Battery & Carrying Case



<b>Impact Energy</b> Kekuatan Impak 单次最大锤击力	EPTA-Procedure 05/2009: 3.1J Our experimental conditions: 3.9J
<b>Impact Per Minute (IPM)</b> Impak Per Minit 冲击数	0 - 3,200
<b>Dimensions (L x W x H)</b> Dimensi 体积	368x99x211mm (14-1/2"x3-7/8"x8-5/16")
<b>Net Weight</b> Berat Bersih 净重	3.3 - 3.6 kg (7.3 - 7.9 lbs.)
<b>Continuous Usage Time (approx.)</b> Masa Penggunaan Berterusan 连续使用时间	17min with BL1850B



\* All list price shown are for reference only (exclude SST).

\* Semua harga yang ditunjukkan adalah untuk rujukan sahaja (tidak termasuk SST). 所有显示的建议零售价仅供参考 (不包括SST)。

Cordless  
Target Model 30.1.15

LED Flashlight  
Lampu Saku LED  
LED工作灯

Vacuum Cleaner  
Pembersih Vakuum  
吸尘器

Drilling / Fastening  
Gantut / Pasang  
钻孔 / 紧固

Impact Drilling / Demolition  
Gantut / Pasang  
钻孔 / 拆除

Cutting  
Potong  
切割

Grinding / Sanding  
Pengkilan / Pasir  
打磨 / 砂磨

Sawing  
Gergaji  
锯切

Planing / Routing  
Pergantian / Tumpang  
刨平 / 嵌条

Others  
Lain-lain  
其他

Outdoor Power Equipment  
Alatan Kuasa Luar  
户外动力设备

Makita  
18V LXT

18V

LXT

Li-ion Ah 6.0 5.0 4.0 3.0 2.0 1.5

**DUT130RFE** | **DUT130Z** | **DUT131Z**  
 RM 2,787 | RM 1,810 | RM 2,548

**Cordless Mixer**  
 Pengadun Tanpa Kord  
 充电式搅拌机



- Battery cover prevents concrete to be scattered on the battery

**Standard Equipment:**

DUT130: Mixing Blade, Shaft, Shaft Holder, Side Grip, Front Cover, Wrenches, Tool Bag

DUT131: Front Cover, Side Grip, Chuck Key, Tool Bag

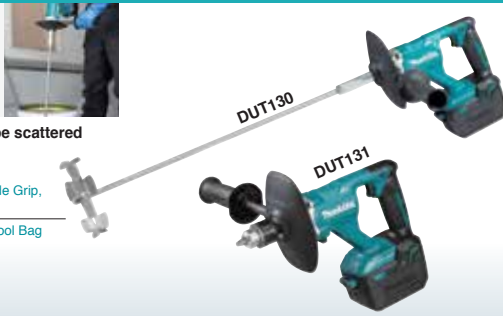
- RFE: 1x Rapid Charger, 2x 3.0Ah Battery
- Z: Without Charger & Battery



<b>Chuck Capacity</b> Kapasiti Chuck 夹头能力	1.5 - 13mm (1/16 - 1/2") <b>DUT131</b>
<b>Blade Diameter</b> Diameter Bilah 锯片直径	165mm (6-1/2") <b>DUT130</b>
<b>Shank size of tool holder portion</b> Batang Saiz 柄部尺寸	M12 or M14 <b>DUT130</b>
<b>No Load Speed (RPM)</b> Kelajuan Tanpa Beban 回转速数	High: 0 - 1,300   Low: 0 - 350
<b>Dimensions (L x W x H)</b> Dimensi 体积	916x89x231mm <b>DUT130</b> (36"x3-1/2"x9-1/8") 307x89x231mm <b>DUT131</b> (12-1/8"x3-1/2"x9-1/8")
<b>Net Weight</b> Berat Bersih 淨重	2.5 - 2.8 kg (5.6 - 6.3 lbs.) <b>DUT130</b> 2.7 - 3.0kg (5.8 - 6.6lbs.) <b>DUT131</b>

**DCS553Z** 150mm (5-7/8")  
 RM 2,087

**Cordless Metal Cutter**  
 Pemotong Logam Tanpa Kord  
 充电式金属切割机

- Built-in dust collection box for cleaner work environment

**Standard Equipment:** TCT Saw Blade, Hex Wrench, Safety Goggles, Guide Rule

- Z: Without Charger & Battery



<b>Max Output</b> Keluaran Maksima 最大输出	600W
<b>Blade Diameter</b> Diameter Bilah 锯片直径	150mm (5-7/8")
<b>Hole Diameter</b> Diameter Lubang 孔直径	20mm (13/16")
<b>Max Cutting Capacity</b> Kapasiti Pemotongan Maksimum 最大切割能力	90°: 57.5mm (2-1/4")
<b>No Load Speed (RPM)</b> Kelajuan Tanpa Beban 回转速数	4,200
<b>Dimensions (L x W x H)</b> Dimensi 体积	267x186x250mm (10-1/2"x7-3/8"x9-7/8")
<b>Net Weight</b> Berat Bersih 淨重	2.8 - 3.1kg (6.1 - 6.8lbs.)
<b>Work Amount (approx.)</b> Jumlah Kerja 工作量	125 cuts with BL1850B Saw Blade - Carbon Steel Pipe Ø 34mm, Thickness 3.2mm

**DCS552Z** 136mm (5-3/8")  
 RM 1,290

**Cordless Metal Cutter**  
 Pemotong Logam Tanpa Kord  
 充电式金属切割机

- Built-in dust collection box for cleaner work environment

**Standard Equipment:** TCT Saw Blade (B-07319), Hex Wrench, Safety Goggles

- Z: Without Charger & Battery



<b>Max Output</b> Keluaran Maksima 最大输出	370W
<b>Blade Diameter</b> Diameter Bilah 锯片直径	136mm (5-3/8")
<b>Hole Diameter</b> Diameter Lubang 孔直径	20mm (13/16")
<b>Max Cutting Capacity</b> Kapasiti Pemotongan Maksimum 最大切割能力	90°: 50.5mm (2")
<b>No Load Speed (RPM)</b> Kelajuan Tanpa Beban 回转速数	3,600
<b>Dimensions (L x W x H)</b> Dimensi 体积	348x196x203mm (13-3/4"x7-3/4"x8")
<b>Net Weight</b> Berat Bersih 淨重	2.4 - 2.7kg (5.3 - 6.0lbs.)
<b>Work Amount (approx.)</b> Jumlah Kerja 工作量	125 cuts with BL1850B Saw Blade - Carbon Steel Pipe Ø 34mm, Thickness 3.2mm

**DCS551RFJ** | **DCS551Z** 150mm (5-7/8")  
 RM 2,835 | RM 1,860

**Cordless Metal Cutter**  
 Pemotong Logam Tanpa Kord  
 充电式金属切割机

- Cuts 51mm (2") conduit in a single pass

**Standard Equipment:** TCT Saw Blade (B-46296), Hex Wrench, Safety Goggles

- RFJ: 1x Rapid Charger, 2x 3.0Ah Battery, 1x Makpac Connector Box
- Z: Without Charger, Battery & Carrying Case



<b>Blade Diameter</b> Diameter Bilah 锯片直径	150mm (5-7/8")
<b>Max Cutting Capacity</b> Kapasiti Pemotongan Maksimum 最大切割能力	90°: 57.5mm (2-1/4")
<b>No Load Speed (RPM)</b> Kelajuan Tanpa Beban 回转速数	3,900
<b>Dimensions (L x W x H)</b> Dimensi 体积	332x158x231mm (13-3/4"x6-1/4"x9-1/8")
<b>Net weight</b> Berat Bersih 淨重	2.5 - 2.8kg (5.5 - 6.2lbs)
<b>Work Amount (approx.)</b> Jumlah Kerja 工作量	210 pcs with BL1850B Saw Blade - Wire Tube Ø 38.1mm, Wall Thickness 1.4mm

**DCS550RFE** | **DCS550Z** 136mm (5-3/8")  
 RM 2,140 | RM 1,165

**Cordless Metal Cutter**  
 Pemotong Logam Tanpa Kord  
 充电式金属切割机

- Carbide-tipped 30T blade for cutting a wide range of materials

**Standard Equipment:** TCT Saw Blade (B-07319), Hex Wrench, Safety Goggles

- RFE: 1x Rapid Charger, 2x 3.0Ah Battery
- Z: Without Charger, Battery & Carrying Case



<b>Blade Diameter</b> Diameter Bilah 锯片直径	136mm (5-3/8")
<b>Max Cutting Capacity</b> Kapasiti Pemotongan Maksimum 最大切割能力	90°: 51mm (2")
<b>No Load Speed (RPM)</b> Kelajuan Tanpa Beban 回转速数	3,600
<b>Dimensions (L x W x H)</b> Dimensi 体积	348x180x201mm (13-3/4"x7-1/8"x7-7/8")
<b>Net weight</b> Berat Bersih 淨重	2.2 - 2.6kg (4.9 - 5.7lbs)
<b>Work Amount (approx.)</b> Jumlah Kerja 工作量	216 pcs with BL1850B Saw Blade - Wire Tube Ø 38.1mm, Wall Thickness 1.4mm

\* All list price shown are for reference only (exclude SST).

\* Semua harga yang ditunjukkan adalah untuk rujukan sahaja (tidak termasuk SST). 所有显示的建议零售价仅供参考 (不包括SST)。

Cordless  
Target Kord 无绳式LED Flashlight  
Lampu Suluh LED  
LED 照明灯Vacuum Cleaner  
Pembersih Vakuum  
吸尘器Drilling / Fastening  
Ganda / Pengikat  
钻孔 / 紧固Impact Drilling / Demolition  
Ganda / Penembak  
起工钻孔 / 拆墙加工Cutting  
Pemotong  
切割Grinding / Sanding  
Pengisar / Piskin  
打磨 / 砂磨Sawing  
Ganda  
锯切Planing / Routing  
Pengisar / Tangkap  
刨削 / 雕刻Others  
Lain-lain  
其他Outdoor Power Equipment  
Alatan Kerja Luar  
园具-户外Makita  
MAKITA



Li-ion Ah 6.0 5.0 4.0 3.0 2.0 1.5

**DJS130RFE** | **DJS130Z** 1.3mm 440 mm  
 RM 2,783 | RM 1,808

**Cordless Metal Shear**  
 Pemotong Logam Tanpa Kord  
 充电式电剪



- 360° swivel shear head for increased cutting convenience

Standard Equipment: Hex Wrench

- RFE: 1x Rapid Charger, 2x 3.0Ah Battery
- Z: Without Charger, Battery & Carrying Case

\*Not applicable for Z model

<b>Capacity</b> Kapasiti 能力	Steel up to 400 N/mm <sup>2</sup> : 1.3mm Steel up to 600 N/mm <sup>2</sup> : 1.0mm 2,800
<b>No Load Speed (RPM)</b> Kelajuan Tanpa Beban 回转数	
<b>Dimensions (L x W x H)</b> Dimensi 体积	350x80x193mm (13-3/4"x3-1/8"x7-5/8")
<b>Net weight</b> Berat Bersih 净重	2.3 - 2.6kg (5.0 - 5.8lbs)
<b>Work Amount</b> (approx.) Jumlah Kerja 工作量	200 pcs with BL1850B Cutting (SPCC Sheet 1.0 x 600mm)

**DJS161Z** 1.6mm 430 mm  
 RM 1,808

**Cordless Straight Shear**  
 Pemotong Logam Lurus  
 Tanpa Kord  
 充电式电剪穿式



- High cutting capacity: cuts up to 1.6mm thick mild steel sheet

Standard Equipment: Hex Wrench, Thickness Gauge

- Z: Without Charger & Battery

<b>Capacity</b> Kapasiti 能力	Steel up to 400 N/mm <sup>2</sup> : 1.6mm Steel up to 600 N/mm <sup>2</sup> : 1.2mm Aluminum up to 200 N/mm <sup>2</sup> : 2.5mm
<b>Strokes Per Minute (SPM)</b> Kelajuan Strok 冲程速度	4,300
<b>Dimensions (L x W x H)</b> Dimensi 体积	362x78x118mm (14-1/4"x3-1/16"x4-5/8")
<b>Net weight</b> Berat Bersih 净重	1.8 - 2.2kg (4.1 - 4.8lbs)
<b>Work Amount</b> (approx.) Jumlah Kerja 工作量	95 pcs with BL1850B Cutting (Thin Metal Plate 1.2mm)

**DJS101Z** 1.0mm 430 mm  
 RM 2,133

**Cordless Metal Shear**  
 Pemotong Logam Tanpa Kord  
 充电式电剪



- Easy curve cutting with a smooth edge

Standard Equipment: Hex Wrench

- Z: Without Charger & Battery

<b>Capacity</b> Kapasiti 能力	Steel up to 400 N/mm <sup>2</sup> : 1.0mm Steel up to 600 N/mm <sup>2</sup> : 0.7mm Aluminum up to 200 N/mm <sup>2</sup> : 2.5mm
<b>Strokes Per Minute (SPM)</b> Kelajuan Strok 冲程速度	4,300
<b>Dimensions (L x W x H)</b> Dimensi 体积	364x78x118mm (14-3/8"x3-1/16"x4-5/8")
<b>Net weight</b> Berat Bersih 净重	1.8 - 2.2kg (4.0 - 4.7lbs)
<b>Work Amount</b> (approx.) Jumlah Kerja 工作量	150 pcs with BL1850B Cutting (Steel sheet SUS430 600x1.0mm)

**DJN161Z** 1.6mm (16Ga) 430 mm  
 RM 2,398

**Cordless Nibbler**  
 Tukul Pemutar Skru Bergerudi  
 Tanpa Kord  
 充电式电冲剪



- Ideal for cutting roofing sheet metal at thicknesses up to 16 gauge

Standard Equipment: Hex Wrench, Wrench, Punch, Die

- Z: Without Charger & Battery

<b>Capacity</b> Kapasiti 能力	Steel up to 400 N/mm <sup>2</sup> : 1.6mm Steel up to 600 N/mm <sup>2</sup> : 1.2mm Aluminum up to 200 N/mm <sup>2</sup> : 2.5mm
<b>Min. Cutting Radius</b> Radius Pemotongan Minimum 最小切割半径	Inside edge: 45mm (1-3/4") Outside edge: 50mm (2")
<b>Strokes Per Minute (SPM)</b> Kelajuan Strok 冲程速度	1,900
<b>Dimensions (L x W x H)</b> Dimensi 体积	313x78x189mm (12-3/8"x3-1/16"x7-7/16")
<b>Net weight</b> Berat Bersih 净重	1.9 - 2.3kg (4.3 - 5.0lbs)
<b>Work Amount</b> (approx.) Jumlah Kerja 工作量	30m with BL1850B Cutting (Steel Plate 1mm)

**DRV250Z** | **DRV150Z**  
 RM 8,315 | RM 8,315

**Cordless Rivet Gun**  
 Penembak Rivet Tanpa Kord  
 充电式拉钉枪



- Compact center height for increased maneuverability against a wall

Standard Equipment: Grease (191D57-7), Accessory Set, Belt Clip

- Z: Without Charger & Battery



<b>Max Pulling Force</b> Kekuatan Tarikan Maksimum 拉钉力量	20kN <b>DRV250</b> 10kN <b>DRV150</b>
<b>Length of Stroke</b> Panjang Strok 冲程长度	30mm (1-3/16") <b>DRV250</b> 25mm (1") <b>DRV150</b>
<b>Dimensions (L x W x H)</b> Dimensi 体积	320x79x287mm <b>DRV250</b> (12-5/8"x3-1/8"x11-1/4") 310x80x287mm <b>DRV150</b> (12-1/4"x3-1/8"x11-1/4")
<b>Net Weight</b> Berat Bersih 净重	2.1 - 2.4kg (4.6 - 5.2lbs.) <b>DRV250</b> 1.9 - 2.2kg (4.3 - 5.0lbs.) <b>DRV150</b>

\* All list price shown are for reference only (exclude SST).  
 \* Semua harga yang ditunjukkan adalah untuk rujukan sahaja (tidak termasuk SST). 所有显示的建议零售价仅供参考 (不包括SST)。

**Cordless**  
 Tanpa Kord / 充电式

**LED Flashlight**  
 Lampu Suluh LED / LED手电筒

**Vacuum Cleaner**  
 Pembasmi Vakuum / 吸尘器

**Drilling / Fastening**  
 Gergaji / Pengikat / 钻孔 / 紧固

**Impact Drilling / Demolition**  
 Gergaji / Pemusnah / 冲击钻孔 / 拆除施工

**Cutting**  
 Pemotong / 切割

**Grinding / Sanding**  
 Pengisar / Pemoles / 研磨 / 砂磨

**Sawing**  
 Gergaji / 锯切

**Planing / Routing**  
 Penyataan / Tunggam / 刨削 / 压花

**Others**  
 Lain-lain / 其他

**Outdoor Power Equipment**  
 Alatan Kuat / 户外动力

**Makita**  
 1915

# Cordless Rebar Tying Tool

Alat Pengikat Rebar Tanpa Kord 充电式钢筋捆绑机

Easy to load with tie wire reel



**1** Push the release lever  
Tekan tuas pelepas 按下釋放桿

**2** Put a reel and pass a wire through the hole  
Letakkan keluli wayar melalui lubang  
將鋼筋線穿過捲筒

**3** Release the lock lever  
Lepaskan tuas kunci 釋放鎖定桿

\*Jumlah Kerja 工作量  
**Work Amount**  
with BL1850B  
(D10 x D10 Rebar)  
**5300 times**  
(approx.)

\*Continuous Usage Time/Work Amount:  
Actual performance may vary based on application.  
Masa Penggunaan Berterusan/Jumlah Kerja: Prestasi sebenar  
mungkin berbeza mengikut aplikasi.  
连续使用时间/工作量: 实际表现可能因应用情况而异。

**Tying Speed**  
Kelajuan mengikat 捆绑速度  
**0.95**  
second with  
(D10 x D10 Rebar)

**1 Reel** about **120 times**  
(D10 x D10 Rebar)

**Accessories**  
Aksesori 配件  
**Tie Wire Set**  
(Ø0.8mm) 50pcs/ box  
Part No. 199137-9



Applicable Rebars: D10 x D10 - (D13 x 2) x (D13 x 2)

	Tying Capacity (2 pcs of rebars)			Tying Capacity (3 pcs of rebars)		Tying Capacity (4 pcs of rebars)	
	D10 (#3)	D13 (#4)	D16 (#5)	D10 (#3) x D10 (#3)	D13 (#4) x D13 (#4)	D10 (#3) x D10 (#3)	D13 (#4) x D13 (#4)
D10 (#3)	✓	✓	✓	✓	✓	✓	✓
D13 (#4)	✓	✓	✓	✓	✓	✓	✓
D16 (#5)	✓	✓	✓	✓	—	✓	✓

(# means perimeter length: cm)

**DTR180ZJ**  
RM 5,697

**Cordless Rebar Tying Tool**  
Alat Pengikat Rebar Tanpa Kord  
充电式钢筋捆绑机



- Continuous actuation mode for efficient continuous rebar tying

Standard Equipment: Hex Wrench, Hook

- ZJ: With 1x Makpac Connector Box, Without Charger & Battery



<b>Tie Wire</b> Wayar Pengikat 绑线	ø0.8mm
<b>Applicable Rebars</b> Keluli yang Sesuai 适用钢筋	D10 x D10 - (D13 x 2) x (D13 x 2)
<b>Dimensions (L x W x H)</b> Dimensi 体积	304x93x318mm (12"x3-2/3"x12-1/2")
<b>Net Weight</b> Berat Bersih 淨重	2.3 - 2.6kg (5.1 - 5.7lbs.)
<b>Work Amount (approx.)</b> Jumlah Kerja 工作量	5300 times with BL1850B Tying (D10 x D10 Rebar)

# Cordless Hole Puncher

Penebuk Lubang Tanpa Kord 充电式油压冲孔机

**Motor section swivels full 360° degrees**

Bahagian motor boleh berpusing 360° darjah  
电机部分可360°度旋转

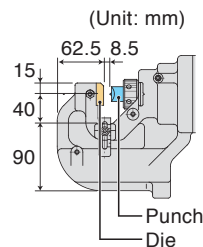

**Punching Capacity** Kapasiti melubang 冲孔能力

	<b>Flat Bar</b> Keluli Rata 扁钢 Max: 80mm x t8 (Center punching)
	<b>Angle</b> Keluli Sudut 角钢 Min: 40mm x 40mm x t3 Max: 80mm x 80mm x t8
	<b>Channel</b> Keluli berbentuk C 型钢 Min: 75mm x 40mm Max: 100mm x 50mm (Flange punching)



**DPP200ZK** Price TBA  
**DPP200Z** Price TBA

**Cordless Hole Puncher**  
Penebuk Lubang Tanpa Kord  
充电式油压冲孔机



- Punches up to 20 mm Holes through Steel Plate up to 8 mm thick

Standard Equipment: Punch, Dice, Hex Wrench, Spanner, Bar for fastening nuts, Grip, Oil

- ZK: With Carrying Case, Without Charger & Battery
- Z: Without Charger & Battery

\*Not applicable for Z model



<b>Capacity</b> Kapasiti 容量	Steel: 20mm (13/16") Stainless Steel: 20mm (13/16") 40mm (1-9/16")
<b>Max Throat Depth</b> Kedalaman Maksimum 最大深度	40mm (1-9/16")
<b>Dimensions (L x W x H)</b> Dimensi 体积	417x127x315mm (16-3/8"x5"x12-3/8")
<b>Net Weight</b> Berat Bersih 淨重	10.5kg (23.2lbs.)

\* All list price shown are for reference only (exclude SST).

\* Semua harga yang ditunjukkan adalah untuk rujukan sahaja (tidak termasuk SST). 所有显示的建议零售价仅供参考 (不包括SST)。

Cordless Target Kord 无绳式  
LED Flashlight Lampu Suluh LED LED 照明灯  
Vacuum Cleaner Pemilauhi VAKUUM 吸尘器  
Drilling / Fastening Druai / Pengikat 钻孔 / 紧固  
Impact Drilling / Demolition Druai / Penanggal 冲击钻孔 / 拆除加工  
Cutting Pemotong 切割  
Grinding / Sanding Pengisar / Pencil 研磨 / 砂磨  
Sawing Gergaji 电锯  
Planing / Routing Pengisar / Tangkapan 刨削 / 雕刻  
Others Lain-lain 其他  
Outdoor Power Equipment Alatan Kerja Luar 户外动力设备





18V

LXT

Li-ion Ah 6.0 5.0 4.0 3.0 2.0 1.5

# Cordless Threaded Rod Cutter

Pemotong Batang Keluli Tanpa Kord 充电式螺纹杆切割机

\*Jumlah Kerja 工作量

**Work Amount**  
with BL1850B  
(Mild steel M10)

**1,330 rods**  
(approx.)

\* Continuous Usage Time/ Work Amount:  
Actual performance may vary based on application.  
Masa Penggunaan Berterusan/ Jumlah Kerja: Prestasi sebenar mungkin berbeza mengikut aplikasi.  
连续使用时间/ 工作量: 实际表现可能因应用而异。

**Cutting Capacity**  
Kapasiti 能力

**M6 - M10**  
(W3/8")



**LED job light**  
Lampu kerja LED  
LED工作灯

**Performs stable cutting even on the floor**  
Pemotongan yang stabil walaupun di lantai  
即使在地板上也能进行稳定的切割

**Rod Guide** There are two rod guide positions  
Terdapat dua kedudukan panduan tuas 有两个杆导向位置

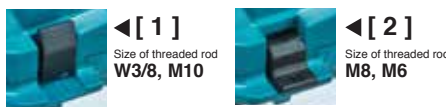

**Blade Cover**  
Can be used as a rod support  
Penutup pisau Boleh digunakan sebagai penyangga rod  
刀片盖可用作杆支撑

**Accessories**  
Aksesori 配件

	<b>Cutter Blade Set</b> Cutting capacities: W3/8 (for •Mild steel •Stainless steel) Part No. 199080-2		<b>Cutter Blade Set</b> Cutting capacities: M6 (for •Mild steel •Stainless steel) Part No. 199086-0		<b>Cutter Blade Set</b> Cutting capacities: M8 (for •Mild steel •Stainless steel) Part No. 199084-4		<b>Cutter Blade Set</b> Cutting capacities: M10 (for •Mild steel) Part No. 199082-8
--	--	--	--	--	--	--	--

**DSC102ZJ**  
RM 5,638

**Cordless Threaded Rod Cutter**  
Pemotong Batang Keluli Tanpa Kord  
充电式螺纹杆切割机

- More Compact & High Productivity



**Standard Equipment:** Cutter Blade, Hex Socket Head Bolt, Blade Cover, Depth Gauge, Thumb Screw, Hex Wrench

- ZJ: With 1x Makpac Connector Box, Without Charger & Battery

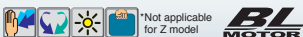

<b>Capacity</b> Kapasiti 能力	Mild Steel: W3/8, M10, M8, M6 Stainless Steel: W3/8, M8, M6
<b>Min. Cutting Length</b> Panjang Pemotongan Minimum 最小切割长度	20mm (13/16")
<b>Dimensions (L x W x H)</b> Dimensi 体积	199x103x308mm (7-7/8"x4-1/16"x12-1/8")
<b>Net Weight</b> Berat Bersih 净重	2.8 - 3.2kg (6.2 - 7.0lbs.)
<b>Work Amount (approx.)</b> Jumlah Kerja 工作量	1330 rods with BL1850B (Mild steel M10)

**DSC121ZK**  
RM 19,053

**Cordless Threaded Rod Cutter**  
Pemotong Batang Berulir Tanpa Kord  
充电式螺纹杆切割机

- Power Cutting at High Speed



**Standard Equipment:** W3/8 Cutter Blade, Stand, Oil, Hex Wrench

- ZK: With 1x Makpac Connector Box, Without Charger & Battery



<b>Capacity</b> Kapasiti 能力	Steel: 8 - 12mm (5/16" - 1/2")
<b>Cutting Speed (sec)</b> Kelajuan Bilah 刀片速度	3.0
<b>Dimensions (L x W x H)</b> Dimensi 体积	212x323x260mm (8-3/8"x12-3/4"x10-1/4")
<b>Net Weight</b> Berat Bersih 净重	6.0kg (13.2lbs.)
<b>Work Amount (approx.)</b> Jumlah Kerja 工作量	420 rods with BL1850B (Mild steel M12)

**DSC162Z DSC163ZK**  
RM 20,457 RM 21,190

**Cordless Steel Rod Cutter**  
Pemotong Keluli Tanpa Kord  
充电式钢筋切割机

- Spark free cutting of rebar and steel rod ideal for use in sensitive areas



**Standard Equipment:** Wrench, Hex Wrench, Oil supply

- Z: Without Charger & Battery
- ZK: With 1x Carrying Case, Without Charger & Battery



<b>Cutting Capacity</b> Kapasiti Pemotongan 切割能力	Dia.: 3 - 16mm (1/8" - 5/8")
<b>Cutting Speed (sec)</b> Kelajuan Memotong 切割速度	4.0 DSC162 2.8 DSC163
<b>Dimensions (L x W x H)</b> Dimensi 体积	380x108x265mm DSC162 (15"x4-1/4"x10-3/8") 360x108x276mm DSC163 (14-1/8"x4-1/4"x10-7/8")
<b>Net Weight</b> Berat Bersih 净重	7.1kg (15.7lbs.) DSC162 6.9kg (15.2lbs.) DSC163
<b>Work Amount (approx.)</b> Jumlah Kerja 工作量	191 pcs with BL1850B DSC162 Cutting (Rebar ø16) 233 pcs with BL1850B DSC163 Cutting (Rebar ø16)

\* All list price shown are for reference only (exclude SST).

\* Semua harga yang ditunjukkan adalah untuk rujukan sahaja (tidak termasuk SST). 所有显示的建议零售价仅供参考 (不包括SST)。

Cordless  
Terdapat Tanpa Kord

LED Flashlight  
Lampu Kerja LED  
LED工作灯

Vacuum Cleaner  
Pembersih Vakuum  
吸尘器

Drilling / Fastening  
Ganda / Pengikat  
钻孔 / 紧固

Impact Drilling / Demolition  
Ganda / Hancurkan  
冲击钻孔 / 拆除施工

Cutting  
Pemotong  
切割

Grinding / Sanding  
Pengiraan / Poles  
研磨 / 打磨

Sawing  
Ganda  
锯切

Planing / Routing  
Pengiraan / Tanggapan  
刨平 / 雕刻

Others  
Lain-lain  
其他

Outdoor Power Equipment  
Alatan Kerja Luar  
户外动力设备

Makita  
Makita



Li-ion Ah 6.0 5.0 4.0 3.0 2.0 1.5

Cordless Target Kord 无绳式  
LED Flashlight Lampu Sulu LED LED 照明灯  
Vacuum Cleaner Pemilauh Vakuu 吸尘器  
Drilling / Fastening Druai / Pemasok 钻孔 / 紧固  
Impact Drilling / Demolition Druai / Penembok 冲击钻孔 / 拆除加工  
Cutting Pemotong 切割  
Grinding / Sanding Pengisar / Pasukan 磨削 / 研磨  
Sawing Gergaji 电锯  
Planing / Routing Pengisar / Tampakan 刨削 / 雕刻  
Others Lain-lain 其他  
Outdoor Power Equipment Alatan Kerja Luar 园林-户外

**DSC191Z**

RM 22,118

440 W

**Cordless Steel Rod Cutter**

Pemotong Keluli Tanpa Kord  
充电式钢筋切割机



- Ideal for cutting steel bars laid in concrete slab

Standard Equipment: Wrench, Hex Wrench, Oil supply

- Z: Without Charger & Battery



<b>Cutting Capacity</b> Kapasiti Pemotongan 切割能力	Dia.: 3 - 20mm (1/8" - 3/4")
<b>Cutting Speed (sec)</b> Kelajuan Memotong 切割速度	6.5
<b>Dimensions (L x W x H)</b> Dimensi 体积	412x212x284mm (16-1/5"x8-3/8"x11-1/8")
<b>Net Weight</b> Berat Bersih 净重	11.1 - 11.2kg (24.5 - 24.6lbs)
<b>Work Amount (approx.)</b> Jumlah Kerja 工作量	333 pcs with BL1850B Cutting (Rebar ø10)

**DSC251ZK**

RM 9,213

**Cordless Steel Rod Cutter**

Pemotong Keluli Tanpa Kord  
充电式钢筋切割机



- Ideal for edge cutting of threaded rods and rebars

Standard Equipment: Tipped Saw, Dust Bag, Side Grip, Hex Wrench

- ZK: Without Charger & Battery



<b>Blade Diameter</b> Diameter Bilah 锯片直径	110mm (4-5/16")
<b>Cutting Capacity</b> Kapasiti Pemotongan 切割能力	Dia.: 10 - 25mm (3/8" - 1")
<b>No Load Speed (RPM)</b> Kelajuan Tanpa Beban 回转速数	2,200
<b>Dimensions (L x W x H)</b> Dimensi 体积	471x137x139mm (18-1/2"x5-3/8"x5-1/2")
<b>Net Weight</b> Berat Bersih 净重	3.9 - 4.0kg (8.7 - 8.8lbs)
<b>Work Amount (approx.)</b> Jumlah Kerja 工作量	60 pcs with BL1850B Cutting Rebar SD345 490N/mm2 D25

**DPB182Z**

RM 1,657

**Cordless Portable Band Saw**

Gergaji Pita Tanpa Kord  
充电式轻便带锯



- Aluminum housing improves rigidity and prevents blade coming off

Standard Equipment: Band Saw Blade, Hex Wrench

- Z: Without Charger & Battery



VIDEO CLIP  
Models and specs may vary by country

<b>Capacity</b> Kapasiti 能力	Round: 64mm (2-1/2") Rectangular: 64x64mm (2-1/2"x2-1/2")
<b>Blade Speed</b> Kelajuan Bilah 刀片速度	3.2m/s (630ft/min.)
<b>Blade Size</b> Saiz Bilah 锯片尺寸	Length: 835mm (32-7/8") Width: 13mm (1/2") Thickness: 0.5mm (0.02")
<b>Dimensions (L x W x H)</b> Dimensi 体积	477x197x229mm (18-3/4"x7-3/4"x9")
<b>Net Weight</b> Berat Bersih 净重	3.8 - 4.1kg (8.3 - 9.0lbs.)

**DPB180Z**

RM 2,717

430 W

**Cordless Portable Band Saw**

Gergaji Pita Tanpa Kord  
充电式轻便带锯



- 6-Setting variable speed control dial enables user to match the speed to the application

Standard Equipment: Band Saw Blade, Hex Wrench

- Z: Without Charger & Battery



<b>Capacity</b> Kapasiti 能力	Round: 120mm (4-3/4") Rectangular workpiece w/o stand: 120x120mm (4-3/4"x4-3/4")
<b>Blade Speed</b> Kelajuan Bilah 刀片速度	1.4-2.7m/s (275-530ft/min.)
<b>Dimensions (L x W x H)</b> Dimensi 体积	523x231x313mm (20-5/8"x9-1/8"x12-3/8")
<b>Net Weight</b> Berat Bersih 净重	6.8 - 7.1kg (14.9 - 15.7lbs)
<b>Work Amount (approx.)</b> Jumlah Kerja 工作量	200 pcs with BL1850B Cutting (Steel Wire Tube Ø38.1mm) (1.4mm Thickness)

\* All list price shown are for reference only (exclude SST).

\* Semua harga yang ditunjukkan adalah untuk rujukan sahaja (tidak termasuk SST). 所有显示的建议零售价仅供参考 (不包括SST)。



**18V** **LXT** **Li-ion** Ah 6.0 5.0 4.0 3.0 2.0 1.5

**AWS**

**Auto - start Wireless System**

**Switch on the tool, and Vacuum cleaner is activated**

Sistem permulaan wayarles automatik 无线自动启动系统

It has been impossible, but now Vacuum cleaner can be automatically activated by Cordless tools with our newly developed wireless system

hidupkan alat dan pembersih vakum akan diaktifkan pembersih vakum boleh diaktifkan secara automatik oleh alat tanpa kord dengan Sistem permulaan wayarles automatik baru

启动工具，吸尘器自动开启我们新研发的无线系统可以通过无线工具自动激活吸尘器



**Bluetooth** AWS connects to power tool with Bluetooth

AWS menyambungkan alat melalui Bluetooth AWS通过蓝牙连接电动工具

The Bluetooth® word mark and logos are registered trademarks owned by the Bluetooth SIG, Inc. and any use of such marks by Makita is under license. Other trademarks and trade names are those of their respective owners.

**ADT**

Automatic Torque Drive Technology  
Teknologi Tork Automatik  
自动扭力驱动科技

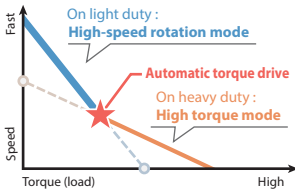

Automatically changes the cutting speed according to load conditions for an optimum operation

Fungsi pertukaran kajuan automatik 自动变速功能

**AFT**

Active Feedback Sensing Technology  
Teknologi Sensor Maklum Balas Automatik  
自动回馈感应科技

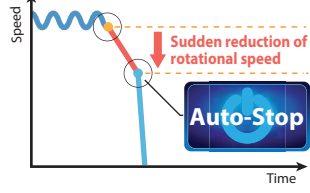

Shuts down the tool to protect the user, if the rotation speed suddenly slows down

Jika kelajuan putaran tiba-tiba dikurangkan, alat akan dimatikan secara automatik untuk melindungi pengguna

若旋转速度突然降低，工具将自动关闭以保护保护使用者

**XLOCK**

Kunci Mata Pengisar X  
砂轮X锁



DGA419, DGA519 only

Just one click to attach the accessories and easy removal just simply pull the lever

Hanya dengan satu klik untuk memasang aksesori dan mudah dilepas hanya tarik tuas

只需单击一下即可安装配件，只需按下红杆即可轻松拆卸

**BL MOTOR**

Motor tanpa berus  
无碳刷马达

Faster Cutting with High power and High torque brushless motor

Pemotongan yang lebih cepat dengan motor tanpa berus berkuasa tinggi

无碳刷马达使切割更快



Electric brake is activated after the tool is switched off

Electric Brake System  
Sistem Brek Elektrik  
电子自动刹车系统

Model No. 型号			No Load Speed (rpm) Kelajuan Tanpa Beban 回转数	Switch Suis 开关	BL MOTOR	AFT	ADT	(BRAKE)	AWS	Anti-restart function Fungsi restart semula 防重复启动功能	XLOCK
100mm	115mm	125mm									
DGA414	-	DGA514	3,000 - 8,500	Slide	●	●	●	●	●	●	
DGA411	-	DGA511	3,000 - 8,500	Slide	●	●	●	●	●	●	
DGA406	DGA456	-	8,500	Slide	●	●	●	●	●	●	
DGA404	-	-	8,500	Slide	●	●	●	●	●	●	
DGA402	DGA452	-	11,000	Slide	●	●	●	●	●	●	
DGA419	-	DGA519	3,000 - 8,500	Paddle	●	●	●	●	●	●	●
DGA418	-	DGA518	3,000 - 8,500	Paddle	●	●	●	●	●	●	
DGA405	-	DGA505	8,500	Paddle	●	●	●	●	●	●	
DGA408	DGA458	DGA508	8,500	Paddle	●	●	●	●	●	●	

**DGA419Z 100mm (4")**  
RM 1,707

**Cordless Angle Grinder**  
Pengisar Sudut Tanpa Kord  
充电式角向磨光机

**Paddle Switch**  
Suis Pemacu 扳机开关



• X-LOCK for toolless accessory changes

Standard Equipment: Grinding Wheel (E-00496), Wheel Cover, Side Grip

• Z: Without Charger, Battery & Carrying Case

BL MOTOR XPT ADT AFT (BRAKE) XLOCK

Wheel Diameter 100mm (4")

Diameter Roda 轮片直径

Hole Diameter 22.23mm (7/8")

Diameter Lubang 孔径

Max Wheel Thickness 6mm (1/4")

Ketebalan Roda Maksimum 最大轮片厚度

No Load Speed (RPM) 3,000 - 8,500

Kelajuan Tanpa Beban 回转数

Dimensions (L x W x H) 396x117x147mm

Dimensi 体积 (15-1/2"x4-5/8"x5-3/4")

Net Weight 2.4 - 3.0kg (5.3 - 6.6lbs.)

Berat Bersih 净重

\* All list price shown are for reference only (exclude SST).

\* Semua harga yang ditunjukkan adalah untuk rujukan sahaja (tidak termasuk SST). 所有显示的建议零售价仅供参考 (不包括SST)。

Cordless  
Target Tools 无线工具

LED Flashlight  
Lampu Suhu LED  
LED手电筒

Vacuum Cleaner  
Pembersih Vakum  
吸尘器

Drilling / Fastening  
Gergaji / Pengikat  
电钻 / 紧固件

Impact Drilling / Demolition  
Gergaji / Pemusnah  
冲击电钻 / 拆除工具

Cutting  
Pemotong  
切割机

Grinding / Sanding  
Pengisar / Plech  
打磨 / 砂磨

Sawing  
Gergaji  
锯切

Planing / Routing  
Pengaliran / Tunggam  
刨削 / 铣削

Others  
Lain-lain  
其他

Outdoor Power Equipment  
Alatan Kuat Luar  
户外动力工具

Others  
Lain-lain  
其他

Others  
Lain-lain  
其他

Others  
Lain-lain  
其他

Others  
Lain-lain  
其他

Others  
Lain-lain  
其他

Others  
Lain-lain  
其他

18V

LXT

Li-ion Ah 6.0 5.0 4.0 3.0 2.0 1.5

**DGA411Z** 100mm (4")  
RM 1,103**Cordless Angle Grinder**  
Pengisar Sudut Tanpa Kord  
充电式角向磨光机**Top Slide Switch**Suis Gelangsar Atas 顶部滑动开关  
**Convenient for left & right handed**  
Mudah diguna dengan tangan kiri atau kanan 方便左右手

- Spiral bevel gear for more efficient transfer of energy

Standard Equipment: Grinding Wheel (A-80852), Wheel Cover, Side Grip, Lock Nut Wrench

- Z: Without Charger & Battery

<b>Wheel Diameter</b> Diameter Roda 轮片直径	100mm (4")
<b>No Load Speed (RPM)</b> Kelajuan Tanpa Beban 回转速数	3,000 - 8,500
<b>Dimensions (L x W x H)</b> Dimensi 体积	BL1850B: 382x117x140mm (15"x4-5/8"x5-1/2")
<b>Net Weight</b> Berat Bersih 淨重	2.2 - 2.8kg (4.8 - 6.1lbs.)
<b>Continuous Usage Time (approx.)</b> Masa Penggunaan Berterusan 连续使用时间	8 min with BL1850B Metal Sanding Pressing Load of 30N, 3000rpm

**DGA414Z** 100mm (4")  
RM 1,637**Cordless Angle Grinder**  
Pengisar Sudut Tanpa Kord  
充电式角向磨光机**Top Slide Switch**Suis Gelangsar Atas 顶部滑动开关  
**Convenient for left & right handed**  
Mudah diguna dengan tangan kiri atau kanan 方便左右手

- Auto-start Wireless System (AWS) connects to compatible vacuum cleaners with Bluetooth

Standard Equipment: Grinding Wheel (A-80852), Wheel Cover, Side Grip, Lock Nut Wrench

- Z: Without Charger & Battery

<b>Wheel Diameter</b> Diameter Roda 轮片直径	100mm (4")
<b>No Load Speed (RPM)</b> Kelajuan Tanpa Beban 回转速数	3,000 - 8,500
<b>Dimensions (L x W x H)</b> Dimensi 体积	BL1850B: 382x117x147mm (15"x4-5/8"x5-3/4")
<b>Net Weight</b> Berat Bersih 淨重	2.2 - 2.8kg (4.9 - 6.3lbs.)
<b>Continuous Usage Time (approx.)</b> Masa Penggunaan Berterusan 连续使用时间	8 min with BL1850B Metal Sanding Pressing Load of 30N, 3000rpm

**DGA418Z** 100mm (4")  
RM 1,707**Cordless Angle Grinder**  
Pengisar Sudut Tanpa Kord  
充电式角向磨光机**Paddle Switch**

Suis Pemacu 扳机开关



- Auto-start Wireless System (AWS) connects to compatible vacuum cleaners with Bluetooth

Standard Equipment: Grinding Wheel (A-80852), Wheel Cover, Side Grip, Lock Nut Wrench

- Z: Without Charger & Battery

<b>Wheel Diameter</b> Diameter Roda 轮片直径	100mm (4")
<b>No Load Speed (RPM)</b> Kelajuan Tanpa Beban 回转速数	3,000 - 8,500
<b>Dimensions (L x W x H)</b> Dimensi 体积	BL1850B: 382x117x146mm (15"x4-5/8"x5-3/4")
<b>Net Weight</b> Berat Bersih 淨重	2.2 - 2.9kg (5.0 - 6.3lbs.)
<b>Continuous Usage Time (approx.)</b> Masa Penggunaan Berterusan 连续使用时间	8 min with BL1850B Metal Sanding Pressing Load of 30N, 3000rpm

**DGA406RME** | **DGA406RFE** | **DGA406Z** 100mm (4")  
RM 2,173 | RM 2,008 | RM 1,033**Cordless Angle Grinder**  
Pengisar Sudut Tanpa Kord  
充电式角向磨光机**Top Slide Switch**Suis Gelangsar Atas 顶部滑动开关  
**Convenient for left & right handed**  
Mudah diguna dengan tangan kiri atau kanan 方便左右手

- Electric brake for increased operator safety

Standard Equipment: Grinding Wheel (A-80852), Wheel Cover, Side Grip, Lock Nut Wrench

- RME: 1x Rapid Charger, 2x 4.0Ah Battery
- RFE: 1x Rapid Charger, 2x 3.0Ah Battery
- Z: Without Charger, Battery & Carrying Case

<b>Wheel Diameter</b> Diameter Roda 轮片直径	100mm (4")
<b>No Load Speed (RPM)</b> Kelajuan Tanpa Beban 回转速数	8,500
<b>Dimensions (L x W x H)</b> Dimensi 体积	362x117x146mm (14-1/4"x4-5/8"x5-3/4")
<b>Net Weight</b> Berat Bersih 淨重	2.18 - 2.77kg (4.81 - 6.12lbs)
<b>Work Amount (approx.)</b> Jumlah Kerja 工作量	12 m with BL1850B Cutting Concrete Depth 10mm

**DGA408RME** | **DGA408RFE** | **DGA408Z** 100mm (4")  
RM 2,242 | RM 2,078 | RM 1,103**Cordless Angle Grinder**  
Pengisar Sudut Tanpa Kord  
充电式角向磨光机**Paddle Switch**

Suis Pemacu 扳机开关



- Efficiency for heavy-duty grinding applications

Standard Equipment: Grinding Wheel (A-80852), Wheel Cover, Side Grip, Lock Nut Wrench

- RME: 1x Rapid Charger, 2x 4.0Ah Battery
- RFE: 1x Rapid Charger, 2x 3.0Ah Battery
- Z: Without Charger, Battery & Carrying Case

<b>Wheel Diameter</b> Diameter Roda 轮片直径	100mm (4")
<b>No Load Speed (RPM)</b> Kelajuan Tanpa Beban 回转速数	8,500
<b>Dimensions (L x W x H)</b> Dimensi 体积	362x117x146mm (14-1/4"x4-5/8"x5-3/4")
<b>Net Weight</b> Berat Bersih 淨重	2.18 - 2.80kg (4.81 - 6.17lbs)
<b>Work Amount (approx.)</b> Jumlah Kerja 工作量	12 m with BL1850B Cutting Concrete Depth 10mm

\* All list price shown are for reference only (exclude SST).

\* Semua harga yang ditunjukkan adalah untuk rujukan sahaja (tidak termasuk SST). 所有显示的建议零售价仅供参考 (不包括SST)。



Li-ion Ah 6.0 | 5.0 | 4.0 | 3.0 | 2.0 | 1.5

**DGA404RTE** | **DGA404RFE** | **DGA404Z** 100mm (4")  
RM 2,248 | RM 1,938 | RM 963

**Cordless Angle Grinder**  
Pengisar Sudut Tanpa Kord  
充电式角向磨光机



**Top Slide Switch**  
Suis Gelangsar Atas 顶部滑动开关  
**Convenient for left & right handed**  
Mudah diguna dengan tangan kiri atau kanan 方便左右手



• Efficient internal cooling for optimum performance

**Standard Equipment:** Grinding Wheel (A-80852), Wheel Cover, Side Grip, Lock Nut Wrench

- RTE: 1x Rapid Charger, 2x 5.0Ah Battery
- RFE: 1x Rapid Charger, 2x 3.0Ah Battery
- Z: Without Charger, Battery & Carrying Case



<b>Wheel Diameter</b> Diameter Roda 轮片直径	100mm (4")
<b>No Load Speed (RPM)</b> Kelajuan Tanpa Beban 回转数	8,500
<b>Dimensions (L x W x H)</b> Dimensi 体积	362x117x140mm (14-1/4"x4-5/8"x5-1/2")
<b>Net Weight</b> Berat Bersih 净重	2.10 - 2.71kg (4.63 - 5.98lbs)
<b>Work Amount (approx.)</b> Jumlah Kerja 工作量	12 m with BL1850B Cutting Concrete Depth 10mm



**DGA405RFE** | **DGA405Z** 100mm (4")  
RM 1,973 | RM 998

**Cordless Angle Grinder**  
Pengisar Sudut Tanpa Kord  
充电式角向磨光机



**Paddle Switch**  
Suis Pemacu 扳机开关



• Efficient internal cooling for optimum performance

**Standard Equipment:** Grinding Wheel (A-80852), Wheel Cover, Side Handle, Lock Nut Wrench

- RFE: 1x Rapid Charger, 2x 3.0Ah Battery
- Z: Without Charger, Battery & Carrying Case



<b>Wheel Diameter</b> Diameter Roda 轮片直径	100mm (4")
<b>No Load Speed (RPM)</b> Kelajuan Tanpa Beban 回转数	8,500
<b>Dimensions (L x W x H)</b> Dimensi 体积	362x117x140mm (14-1/4"x4-5/8"x5-1/2")
<b>Net Weight</b> Berat Bersih 净重	2.08 - 2.69kg (4.59 - 5.94lbs)
<b>Work Amount (approx.)</b> Jumlah Kerja 工作量	12 m with BL1850B Cutting Concrete Depth 10mm

**DGA402RFE** | **DGA402Z** 100mm (4")  
RM 1,532 | RM 557

**Cordless Angle Grinder**  
Pengisar Sudut Tanpa Kord  
充电式角向磨光机



**Top Slide Switch**  
Suis Gelangsar Atas 顶部滑动开关  
**Convenient for left & right handed**  
Mudah diguna dengan tangan kiri atau kanan 方便左右手



• Spiral bevel gear for more efficient transfer of energy

**Standard Equipment:** Grinding Wheel (A-80852), Wheel Cover, Side Grip, Lock Nut Wrench

- RFE: 1x Rapid Charger, 2x 3.0Ah Battery
- Z: Without Charger, Battery & Carrying Case



<b>Wheel Diameter</b> Diameter Roda 轮片直径	100mm (4")
<b>No Load Speed (RPM)</b> Kelajuan Tanpa Beban 回转数	11,000
<b>Dimensions (L x W x H)</b> Dimensi 体积	317x118x118mm (12-1/2"x4-5/8"x4-5/8")
<b>Net Weight</b> Berat Bersih 净重	1.90 - 2.51kg (4.19 - 5.5 lbs)
<b>Work Amount (approx.)</b> Jumlah Kerja 工作量	13.5 m with BL1850B Cutting Concrete Depth 5mm

**DGA456RFE** | **DGA456Z** 115mm (4-1/2")  
RM 2,028 | RM 1,053

**Cordless Angle Grinder**  
Pengisar Sudut Tanpa Kord  
充电式角向磨光机



**Top Slide Switch**  
Suis Gelangsar Atas 顶部滑动开关  
**Convenient for left & right handed**  
Mudah diguna dengan tangan kiri atau kanan 方便左右手



• Efficiency for heavy-duty grinding applications

**Standard Equipment:** Grinding Wheel (A-80640), Wheel Cover, Side Handle, Lock Nut Wrench

- RFE: 1x Rapid Charger, 2x 3.0Ah Battery
- Z: Without Charger, Battery & Carrying Case



<b>Wheel Diameter</b> Diameter Roda 轮片直径	115mm (4-1/2")
<b>No Load Speed (RPM)</b> Kelajuan Tanpa Beban 回转数	8,500
<b>Dimensions (L x W x H)</b> Dimensi 体积	362x130x151mm (14-1/4"x5-1/8"x5-15/16")
<b>Net Weight</b> Berat Bersih 净重	2.34 - 3.03kg (5.17 - 6.67lbs)
<b>Work Amount (approx.)</b> Jumlah Kerja 工作量	12 m with BL1850B Cutting Concrete Depth 10mm

**DGA458RFE** | **DGA458Z** 115mm (4-1/2")  
RM 2,098 | RM 1,123

**Cordless Angle Grinder**  
Pengisar Sudut Tanpa Kord  
充电式角向磨光机



**Paddle Switch**  
Suis Pemacu 扳机开关



• Electric brake for increased operator safety

**Standard Equipment:** Grinding Wheel (A-80640), Wheel Cover, Side Handle, Lock Nut Wrench

- RFE: 1x Rapid Charger, 2x 3.0Ah Battery
- Z: Without Charger, Battery & Carrying Case



<b>Wheel Diameter</b> Diameter Roda 轮片直径	115mm (4-1/2")
<b>No Load Speed (RPM)</b> Kelajuan Tanpa Beban 回转数	8,500
<b>Dimensions (L x W x H)</b> Dimensi 体积	362x130x151mm (14-1/4"x5-1/8"x5-15/16")
<b>Net Weight</b> Berat Bersih 净重	2.34 - 3.03kg (5.17 - 6.67lbs)
<b>Work Amount (approx.)</b> Jumlah Kerja 工作量	12 m with BL1850B Cutting Concrete Depth 10mm

\* All list price shown are for reference only (exclude SST).

\* Semua harga yang ditunjukkan adalah untuk rujukan sahaja (tidak termasuk SST). 所有显示的建议零售价仅供参考 (不包括SST)。

Cordless  
Target: No Cord

LED Flashlight  
Lampu Suis LED  
LED 照明灯

Vacuum Cleaner  
Pembersih Vakuum  
吸尘器

Drilling / Fastening  
Gantuli / Pasang  
钻孔 / 紧固

Impact Drilling / Demolition  
Gantuli / Penehah  
冲击钻孔 / 拆除施工

Cutting  
Panasah  
切割

Grinding / Sanding  
Pengisar / Pasah  
研磨 / 砂磨

Sawing  
Gantuli  
锯切

Planing / Routing  
Penghalus / Tumpang  
刨平 / 压光

Others  
Lain-lain  
其他

Outdoor Power Equipment  
Alatan Kuasa Luar  
户外动力设备

Thakita  
TENT

18V

LXT

Li-ion Ah 6.0 5.0 4.0 3.0 2.0 1.5

<b>DGA452RME</b> RM 1,722	<b>DGA452RFE</b> RM 1,557	<b>DGA452Z</b> 115mm (4-1/2") RM 582	430 mm
------------------------------	------------------------------	---	--------

**Cordless Angle Grinder**  
Pengisar Sudut Tanpa Kord  
充电式角向磨光机



**Top Slide Switch**  
Suis Gelangsar Atas 顶部滑动开关  
**Convenient for left & right handed**  
Mudah diguna dengan tangan kiri atau kanan 方便左右手



- Compact barrel grip for easy handling

**Standard Equipment:** Grinding Wheel (A-80640), Wheel Cover, Side Handle, Lock Nut Wrench

- RME: 1x Rapid Charger, 2x 4.0Ah Battery
- RFE: 1x Rapid Charger, 2x 3.0Ah Battery
- Z: Without Charger, Battery & Carrying Case

\*Not applicable for Z model

<b>Wheel Diameter</b> Diameter Roda 轮片直径	115mm (4-1/2")
<b>No Load Speed (RPM)</b> Kelajuan Tanpa Beban 回转数	11,000
<b>Dimensions (L x W x H)</b> Dimensi 体积	317x129x126mm (12-1/2"x5-1/8"x5")
<b>Net Weight</b> Berat Bersih 淨重	2.06 - 2.71kg (4.53 - 5.97lbs)
<b>Work Amount (approx.)</b> Jumlah Kerja 工作量	25 m with BL1850B Cutting Concrete Depth 5mm

# Cordless Angle Grinder

Pengisar Sudut Tanpa Kord  
充电式角向磨光机

# XLOCK

JUST ONE CLICK TO ATTACH THE ACCESSORIES AND EASY REMOVAL  
JUST SIMPLY PULL THE LEVER

Hanya dengan satu klik untuk memasang aksesori dan mudah dilepas hanya tarik tuas  
只需单击一下即可安装配件，只需按下杠杆即可轻松拆卸



**Variable speed control dial**  
Dail kawalan kelajuan ubah 变速控制拨盘

**Wheel release lever**  
Pelepas roda 轮片释放杆

**Paddle Switch**  
Suis Pemacu 扳机开关

## INSTALLATION



## REMOVAL



<b>DGA519Z</b> 125mm (5") RM 1,747
---------------------------------------

**Cordless Angle Grinder**  
Pengisar Sudut Tanpa Kord  
充电式角向磨光机



**Paddle Switch**  
Suis Pemacu 扳机开关



- X-LOCK for toolless accessory changes

**Standard Equipment:** Grinding Wheel (E-00402), Wheel Cover, Side Grip

- Z: Without Charger, Battery & Carrying Case

\*Not applicable for Z model

<b>Wheel Diameter</b> Diameter Roda 轮片直径	125mm (5")
<b>Hole Diameter</b> Diameter Lubang 孔直径	22.23mm (7/8")
<b>Max Wheel Thickness</b> Ketebalan Roda Maksimum 最大轮片厚度	6mm (1/4")
<b>No Load Speed (RPM)</b> Kelajuan Tanpa Beban 回转数	3,000 - 8,500
<b>Dimensions (L x W x H)</b> Dimensi 体积	396x140x147mm (15-1/2"x5-1/2"x5-3/4")
<b>Net Weight</b> Berat Bersih 淨重	2.5 - 3.1kg (5.5 - 6.8lbs.)

\* All list price shown are for reference only (exclude SST).

\* Semua harga yang ditunjukkan adalah untuk rujukan sahaja (tidak termasuk SST). 所有显示的建议零售价仅供参考 (不包括SST)。

Cordless Target Kord 无绳式  
LED Flashlight Lampu Suluh LED LED照明灯  
Vacuum Cleaner Pemilauhi VAKUUM 吸尘器  
Drilling / Fastening Daurul / Pengikat 钻孔 / 紧固  
Impact Drilling / Demolition Daurul / Penroboh 冲击钻孔 / 拆卸加工  
Cutting Pemotong 切割  
Grinding / Sanding Pengisar / Piskin 研磨 / 砂磨  
Sawing Gergaji 锯切  
Planing / Routing Pengisar / Tangkapan 刨削 / 雕刻  
Others Lain-lain 其他  
Outdoor Power Equipment Alatan Kerja Luar 园机-户外





Li-ion Ah 6.0 5.0 4.0 3.0 2.0 1.5

**DGA511Z** 125mm (5")  
RM 1,140

**Cordless Angle Grinder**  
Pengisar Sudut Tanpa Kord  
充电式角向磨光机



**Top Slide Switch**  
Suis Gelangsar Atas 顶部滑动开关  
**Convenient for left & right handed**  
Mudah diguna dengan tangan kiri atau kanan 方便左右手操作



- Spiral bevel gear for more efficient transfer of energy

**Standard Equipment:** Grinding Wheel (A-80656), Wheel Cover, Side Grip, Lock Nut Wrench

• Z: Without Charger & Battery



<b>Wheel Diameter</b> Diameter Roda 轮片直径	125mm (5")
<b>No Load Speed (RPM)</b> Kelajuan Tanpa Beban 回转数	3,000 - 8,500
<b>Dimensions (L x W x H)</b> Dimensi 体积	BL1850B: 382x140x145mm (15"x5-1/2"x5-3/4")
<b>Net Weight</b> Berat Bersih 净重	2.3 - 3.0kg (5.1 - 6.6lbs.)
<b>Work Amount (approx.)</b> Jumlah Kerja 工作量	13.8 m with BL1850B Cutting Concrete Depth 10mm

**DGA514Z** 125mm (5")  
RM 1,675

**Cordless Angle Grinder**  
Pengisar Sudut Tanpa Kord  
充电式角向磨光机

**Top Slide Switch**  
Suis Gelangsar Atas 顶部滑动开关  
**Convenient for left & right handed**  
Mudah diguna dengan tangan kiri atau kanan 方便左右手操作



- Auto-start Wireless System (AWS) connects to compatible vacuum cleaners with Bluetooth

**Standard Equipment:** Grinding Wheel (A-80656), Wheel Cover, Side Grip, Lock Nut Wrench

• Z: Without Charger & Battery



<b>Wheel Diameter</b> Diameter Roda 轮片直径	125mm (5")
<b>No Load Speed (RPM)</b> Kelajuan Tanpa Beban 回转数	3,000 - 8,500
<b>Dimensions (L x W x H)</b> Dimensi 体积	BL1850B: 382x140x151mm (15"x5-1/2"x5-15/16")
<b>Net Weight</b> Berat Bersih 净重	2.4 - 3.0kg (5.2 - 6.7lbs.)
<b>Work Amount (approx.)</b> Jumlah Kerja 工作量	13.8 m with BL1850B Cutting Concrete Depth 10mm

**DGA518Z** 125mm (5")  
RM 1,747

**Cordless Angle Grinder**  
Pengisar Sudut Tanpa Kord  
充电式角向磨光机

**Paddle Switch**  
Suis Pemacu 扳机开关



- Auto-start Wireless System (AWS) connects to compatible vacuum cleaners with Bluetooth

**Standard Equipment:** Grinding Wheel (A-80656), Wheel Cover, Side Grip, Lock Nut Wrench

• Z: Without Charger & Battery



<b>Wheel Diameter</b> Diameter Roda 轮片直径	125mm (5")
<b>No Load Speed (RPM)</b> Kelajuan Tanpa Beban 回转数	3,000 - 8,500
<b>Dimensions (L x W x H)</b> Dimensi 体积	BL1850B: 382x140x151mm (15"x5-1/2"x6")
<b>Net Weight</b> Berat Bersih 净重	2.4 - 3.1kg (5.3 - 6.8lbs.)
<b>Work Amount (approx.)</b> Jumlah Kerja 工作量	13.8 m with BL1850B Cutting Concrete Depth 10mm

**DGA508RFE** | **DGA508Z** 125mm (5")  
RM 2,113 | RM 1,138

**Cordless Angle Grinder**  
Pengisar Sudut Tanpa Kord  
充电式角向磨光机

**Paddle Switch**  
Suis Pemacu 扳机开关



- Electric brake for increased operator safety

**Standard Equipment:** Grinding Wheel (A-80656), Wheel Cover, Side Handle, Lock Nut Wrench

• RFE: 1x Rapid Charger, 2x 3.0Ah Battery  
• Z: Without Charger, Battery & Carrying Case



<b>Wheel Diameter</b> Diameter Roda 轮片直径	125mm (5")
<b>No Load Speed (RPM)</b> Kelajuan Tanpa Beban 回转数	8,500
<b>Dimensions (L x W x H)</b> Dimensi 体积	362x140x151mm (14-1/4"x5-1/2"x5-15/16")
<b>Net weight</b> Berat Bersih 净重	2.35 - 3.83kg (5.18 - 8.45lbs)
<b>Work Amount (approx.)</b> Jumlah Kerja 工作量	13.8 m with BL1850B Cutting Concrete Depth 10mm

**DGA505RFE** | **DGA505Z** 125mm (5")  
RM 2,008 | RM 1,033

**Cordless Angle Grinder**  
Pengisar Sudut Tanpa Kord  
充电式角向磨光机

**Paddle Switch**  
Suis Pemacu 扳机开关



- Efficient internal cooling for optimum performance

**Standard Equipment:** Grinding Wheel (A-80656), Wheel Cover, Side Handle, Lock Nut Wrench

• RFE: 1x Rapid Charger, 2x 3.0Ah Battery  
• Z: Without Charger, Battery & Carrying Case



<b>Wheel Diameter</b> Diameter Roda 轮片直径	125mm (5")
<b>No Load Speed (RPM)</b> Kelajuan Tanpa Beban 回转数	8,500
<b>Dimensions (L x W x H)</b> Dimensi 体积	362x140x145mm (14-1/4"x5-1/2"x5-3/4")
<b>Net weight</b> Berat Bersih 净重	2.26 - 3.73kg (4.98 - 8.23lbs)
<b>Work Amount (approx.)</b> Jumlah Kerja 工作量	13.8 m with BL1850B Cutting Concrete Depth 10mm

\* All list price shown are for reference only (exclude SST).

\* Semua harga yang ditunjukkan adalah untuk rujukan sahaja (tidak termasuk SST). 所有显示的建议零售价仅供参考 (不包括SST)。

Cordless  
Target: No Cord

LED Flashlight  
Lampu Sulu LED  
LED照明灯

Vacuum Cleaner  
Pembersih Vakuum  
吸尘器

Drilling / Fastening  
Ganda / Pengikat  
钻孔 / 紧固

Impact Drilling / Demolition  
Ganda / Penusuk  
冲击钻孔 / 拆除施工

Cutting  
Pemotong  
切割

Grinding / Sanding  
Pengisar / Poles  
研磨 / 砂磨

Sawing  
Ganda  
锯切

Planing / Routing  
Pengaliran / Tumpang  
刨削 / 压花

Others  
Lain-lain  
其他

Outdoor Power Equipment  
Alatan Kerja Luar  
园机/户外



18V

LXT

Li-ion Ah 6.0 | 5.0 | 4.0 | 3.0 | 2.0 | 1.5

# Cordless Random Orbit Polisher

Pelicin Orbit Tanpa Kord 充电式砂光机

\*Masa Penggunaan Berterusan  
连续使用时间
**Continuous Usage Time**  
with BL1850B  
(Finishing Mode)

**30min**  
(approx.)

\* Continuous Usage Time/ Work Amount:  
Actual performance may vary based on application.  
Masa Penggunaan Berterusan/ Jumlah Kerja: Prestasi sebenar  
mungkin berbeza mengikut aplikasi.  
连续使用时间/ 工作量: 实际使用效能可能因应用而异。

## High Power for Professional

Kuasa Tinggi untuk Profesional 高功率专业用途



### ROUGH POLISHING

Penggilapan kasar 强制旋转模式

#### Forcible rotation mode

Orbital action with forced rotation of the pad for rough polishing such as scratch removal.

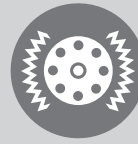

### FINE POLISHING

Penggilapan halus 自由旋转模式

#### Free rotation mode

Orbital action with free rotation of the pad for fine polishing.

**DPO600Z** | **DPO500Z**  
RM 2,528 | RM 2,515

**Cordless Random Orbit Polisher**  
Pelicin Orbit Tanpa Kord  
充电式砂光机

- Selectable two rotation mode: normal mode & finishing mode



Standard Equipment: Hex Wrench

- Z: Without Charger & Battery



<b>Pad Size</b> Saiz Pad 垫大小	150mm (6") <b>DPO600</b> 125mm (5") <b>DPO500</b>
<b>Orbits Per Minute (OPM)</b> Bilangan Putaran 轨道转数	Normal mode: 0 - 6,800 Finishing mode: 0 - 5,200
<b>Strokes Per Minute (SPM)</b> Kelajuan Strok 冲程速度	Normal mode: 0 - 13,600 Finishing mode: 0 - 10,400
<b>No Load Speed (RPM)</b> Kelajuan Tanpa Beban 回转速数	Normal mode: 0 - 780 Finishing mode: 0 - 600
<b>Orbit Diameter</b> Kelajuan Tanpa Beban 回转数	5.5mm (7/32")
<b>Dimensions (L x W x H)</b> Dimensi 体积	530x148x126mm <b>DPO600</b> (20-7/8"x5-7/8"x5") 530x123x134mm <b>DPO500</b> (20-7/8"x4-7/8"x5-1/4")
<b>Net Weight</b> Berat Bersih 淨重	3.1 - 3.6kg (6.8 - 7.9lbs.)

**DGD800Z**  
RM 608

430

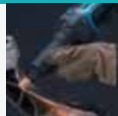
**Cordless Die Grinder**  
Pengisar Tanpa Kord  
充电式刻磨机

- Slide switch with lock-on for operator convenience



Standard Equipment: Wrench x2

- Z: Without Charger & Battery

**DGD801Z**  
RM 608

430

**Cordless Die Grinder**  
Pengisar Tanpa Kord  
充电式刻磨机

- Round collet nut reduces the risk of damages



Standard Equipment: Wrench x2

- Z: Without Charger & Battery

<b>Capacity</b> Kapasiti 能力	Collet : 3mm - 8mm
<b>Wheel Diameter</b> Diameter Roda 轮片直径	38mm (1-1/2")
<b>No Load Speed (RPM)</b> Kelajuan Tanpa Beban 回转速数	26,000
<b>Dimensions (L x W x H)</b> Dimensi 体积	402x82x118mm (15-3/4"x3-1/4"x4-5/8")
<b>Net Weight</b> Berat Bersih 淨重	1.7 - 2.2kg (3.8 - 4.9lbs)
<b>Work Amount (approx.)</b> Jumlah Kerja 工作量	9.0 g with BL1850B Grinding Steel Plate SS400

<b>Capacity</b> Kapasiti 能力	Collet : 3mm - 8mm
<b>Wheel Diameter</b> Diameter Roda 轮片直径	38mm (1-1/2")
<b>No Load Speed (RPM)</b> Kelajuan Tanpa Beban 回转速数	25,000
<b>Dimensions (L x W x H)</b> Dimensi 体积	307x82x118mm (12-1/8"x3-1/4"x4-5/8")
<b>Net Weight</b> Berat Bersih 淨重	1.5 - 2.0kg (3.3 - 4.3lbs)
<b>Work Amount (approx.)</b> Jumlah Kerja 工作量	9.5 g with BL1850B Grinding Steel Plate SS400

\* All list price shown are for reference only (exclude SST).

\* Semua harga yang ditunjukkan adalah untuk rujukan sahaja (tidak termasuk SST). 所有显示的建议零售价仅供参考 (不包括SST)。

Cordless  
Tanpa Kord 充电式LED Flashlight  
Lampu Suluh LED  
LED 照明灯Vacuum Cleaner  
Pembersih Vakuüm  
吸尘器Drilling / Fastening  
Ganjal / Pengetat  
钻孔 / 紧固Impact Drilling / Demolition  
Ganjal / Penembak  
冲击钻孔 / 拆除加工Cutting  
Pemotong  
切割Grinding / Sanding  
Pengisar / Piskin  
研磨 / 砂磨Sawing  
Ganjal  
锯切Planing / Routing  
Pengisar / Tangkapan  
刨削 / 雕刻Others  
Lain-lain  
其他Outdoor Power Equipment  
Alatan Kerja Luar  
园林-户外Makita  
MAKITA



18V

LXT

Li-ion Ah 6.0 5.0 4.0 3.0 2.0 1.5

# Cordless Drywall Sander

Pelicin Drywall Tanpa Kord 充电式石膏板砂光机

\*Masa Penggunaan Berterusan  
连续使用时间

**Continuous Usage Time**  
with BL1850B  
(Speed dial 3)

**35min**  
(approx.)

\* Continuous Usage Time/Work Amount: Actual performance may vary based on application. Masa Penggunaan Berterusan/ Jumlah Kerja: Prestasi sebenar mungkin berubah mengikut aplikasi. 连续使用时间/ 工作量: 实际使用可能因应用而异。



**AWS**  
Auto-start Wireless System

Sistem permulaan wayarles automatik  
无线自动启动系统

Wireless unit is compatible with all supported tools  
Unit wayarles serasi dengan semua alat yang disokong  
无线设备与所有支持的工具兼容

The wireless activation function enables clean and comfortable operation. By connecting a supported tool to the cleaner, you can run the cleaner automatically along with the switch operation of the tool  
Fungsi pengaktifan tanpa wayar membolehkan operasi yang bersih dan selesa. Dengan menyambungkan alat kuasa dengan pembersih, anda boleh menjalankan pembersihan secara automatik dengan operasi suis alat tersebut  
无线装置让工作环境更清淨。自动启动无线系统透过蓝牙连接到吸尘器。启动工具吸尘器将自动运行



**Aluminum pipe**  
Paip aluminium 铝管

**Variable speed control dial**  
1,000 - 1,800min<sup>-1</sup>  
Dail kawalan kelajuan ubah 变速控制拨盘

**Length adjustable telescopic pipe from 1,100mm to 1,520mm**  
Pelarasan panjang paip teleskopik dari 1,100mm hingga 1,520mm  
可调节伸缩管从1,100mm至1,520mm

**Roller**  
Roller 滚轴

**Dust collecting brush**  
Berus mengumpul habuk 集尘刷



**Tool length adjustable for various jobsites**

Panjang alat boleh laras untuk pelbagai kerja  
工具长度可调节适用于各种工作

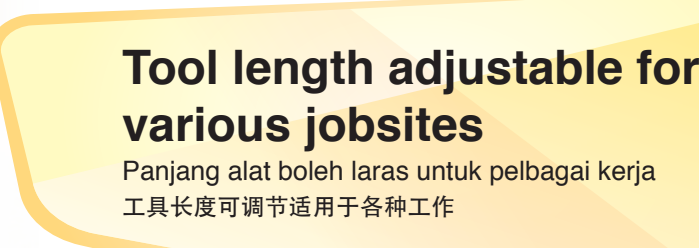

**Accessories**  
Aksesori 配件

**Pad**

Type	Part No.
Soft	199939-3
Medium	199940-8
Hard	199938-5

**Abrasive disc 225**

Grit	Part No.
40	B-68389
80	B-68395
120	B-68404
180	B-68410
320	B-68426



**DSL800Z** 225mm (8-7/8")  
RM 5,407

**Cordless Drywall Sander**  
Pelicin Drywall Tanpa Kord  
充电式石膏板砂光机

- Easy handling by cordless

**Standard Equipment:** Abrasive Disc, Hex Wrench, Tool Bag

• 2: Without Charger & Battery



<b>Pad diameter</b> Diameter Pad 垫片直径	210mm (8-1/4")
<b>Abrasive Disc Size</b> Saiz Cakera 磨盘尺寸	225mm (8-7/8")
<b>No Load Speed (RPM)</b> Kelajuan Tanpa Beban 回转速	1,000 - 1,800
<b>Dimensions (L x W x H)</b> Dimensi 体积	1,100-1,520x259x273mm (43-1/4"-59-3/4"x10-1/4"x10-3/4")
<b>Net Weight</b> Berat Bersih 淨重	4.5 - 5.7kg (10.0 - 12.6lbs.)
<b>Continuous Usage Time (approx.)</b> Masa Penggunaan Berterusan 连续使用时间	35 min with BL1850B Speed Dial 3



\* All list price shown are for reference only (exclude SST).  
\* Semua harga yang ditunjukkan adalah untuk rujukan sahaja (tidak termasuk SST). 所有显示的建议零售价仅供参考 (不包括SST)。

Cordless  
Target Tools Series

LED Flashlight  
Lampu Suluh LED  
LED手电筒

Vacuum Cleaner  
Pembersih Vakuum  
吸尘器

Drilling / Fastening  
Gergaji / Pengikat  
电钻 / 紧固件

Impact Drilling / Demolition  
Gergaji / Pemusnah  
冲击电钻 / 拆除工具

Cutting  
Pemotong  
切割机

Grinding / Sanding  
Pengkilan / Poles  
研磨 / 砂磨

Sawing  
Gergaji  
锯切

Planing / Routing  
Pengkilan / Tanggung  
刨削 / 导槽

Others  
Lain-lain  
其他

Outdoor Power Equipment  
Alatan Kuasa Luar  
户外动力

**Makita**  
POWER TOOL

18V

LXT

Li-ion Ah 6.0 | 5.0 | 4.0 | 3.0 | 2.0 | 1.5

# Cordless Multi Tool

Pemotong dan Pengisar Pelbagai Fungsi Tanpa Kord 充电式多功能切割打磨机



## WIDE SELECTION OF ACCESSORIES

Pelbagai pilihan aksesori 广泛的配件选择



Compatible with all OIS accessories (Oscillating Interface System)



**DTM51RFEX8** RM 2,252 | **DTM51Z** RM 1,163

**Cordless Multi Tool**  
Pemotong dan Pengisar Pelbagai Fungsi Tanpa Kord  
充电式多功能切割打磨机



• 12 Angle settings at every 30° from 0° to 360°

Standard Equipment:  
DTM51RFEX8: Oscillating multi tool accessories, Tool Box

- RFX8: 1x Rapid Charger, 2x 3.0Ah Battery
- Z: Without Charger, Battery & Carrying Case

\*Not applicable for Z model



<b>Oscillations Per Minute (OPM)</b> Kelajuan Ayunan 摆动速度	6,000 - 20,000
<b>Oscillation Angle</b> Sudut Ayunan 摆动角度	Left: 1.6°   Right: 1.6°   Total: 3.2°
<b>Dimensions (L x W x H)</b> Dimensi 体积	340x80x122mm (13-3/8"x3-1/8"x4-13/16")
<b>Net Weight</b> Berat Bersih 净重	2.0 - 2.4kg (4.4 - 5.3lbs)
<b>Work Amount (approx.)</b> Jumlah Kerja 工作量	40 pcs with BL1850B Cutting

**DTM50Z**  
RM 987

**Cordless Multi Tool**  
Pemotong dan Pengisar Pelbagai Fungsi Tanpa Kord  
充电式多功能切割打磨机



• High operating efficiency

Standard Equipment: Hex Wrench

- Z: Without Charger & Battery

<b>Oscillations Per Minute (OPM)</b> Kelajuan Swing 摆动速度	6,000 - 20,000
<b>Dimensions (L x W x H)</b> Dimensi 体积	307x80x122mm (12-1/4"x3-1/8"x4-13/16")
<b>Net Weight</b> Berat Bersih 净重	1.8 - 2.2kg (3.9 - 4.8lbs)
<b>Work Amount (approx.)</b> Jumlah Kerja 工作量	35 pcs with BL1850B Cutting

\* All list price shown are for reference only (exclude SST).

\* Semua harga yang ditunjukkan adalah untuk rujukan sahaja (tidak termasuk SST). 所有显示的建议零售价仅供参考 (不包括SST)。

Cordless  
Target Kord 无绳式

LED Flashlight  
Lampu Suluhi LED  
LED 照明灯

Vacuum Cleaner  
Pembersih Vakuum  
吸尘器

Drilling / Fastening  
Drauli / Pasang  
钻孔 / 紧固

Impact Drilling / Demolition  
Drauli / Persekol  
冲击钻孔 / 拆除加工

Cutting  
Pemotong  
切割

Grinding / Sanding  
Pengisar / Pasir  
磨削 / 打磨

Sawing  
Gergaji  
锯切

Planing / Routing  
Pengisar / Tampam  
刨削 / 雕刻

Others  
Lain-lain  
其他

Outdoor Power Equipment  
Alatan Kerja Luar  
园林-户外





Li-ion Ah 6.0 | 5.0 | 4.0 | 3.0 | 2.0 | 1.5

**DBO180Z** 125mm (5")  
RM 792

**Cordless Random Orbit Sander**

Pelicin Orbit Tanpa Kord  
充电式砂光机



- Three speed control switch fast, medium and low

Standard Equipment: Abrasive Paper, Dust Bag

• Z : Without Charger & Battery



<b>Pad Diameter</b> Diameter Pad 垫片直径	123mm (4-7/8")
<b>Abrasive Disc Size</b> Saiz Cakera 磨盘尺寸	125mm (5")
<b>Orbits Per Minute (OPM)</b> Bilangan Putaran 轨道转速	7,000   9,500   11,000
<b>Dimensions (L x W x H)</b> Dimensi 体积	175x123x153mm (6-7/8"x4-7/8"x6")
<b>Net Weight</b> Berat Bersih 净重	1.4 - 1.7kg (3.0 - 3.7lbs)
<b>Continuous Usage Time (approx.)</b> Masa Penggunaan Berterusan 连续使用时间	66 min with BL1850B Low Speed Sanding

# Cordless Compound Miter Saw

Gergaji Kompaun Miter Tanpa Kord 充电式斜断锯

**LED job light**  
Lampu LED 工作指示灯

**Can be attached with a vacuum cleaner**  
Boleh dihubungkan dengan alat kuasa  
能够连接电动工具

**Laser line function**  
Garis laser sebagai penanda  
garisan potong  
激光线作为切线引导



**Max. cutting capacity (mm) (height x width) with 165mm (6-1/2") saw blade**  
Kapasiti potongan maksimum dengan menggunakan bilah gergaji 165mm (6-1/2") 最大切割能力 使用165mm (6-1/2") 锯片

Cross Cut Potongan Cross 交错切割	Miter Cut (left & right) Potongan Miter 左右切割	Bevel Cut (left & right) Potongan Bevel 左右斜角切割	Compound Cut Potongan Compound 复合切割
 46 x 92 (1-13/16" x 3-5/8")	 Miter: 45° left/ right 46 x 65 (1-13/16" x 2-9/16") Miter: 52° left/ right 46 x 56 (1-13/16" x 2-3/16")	 Bevel: 45° left 30 x 92 (1-3/16" x 3-5/8") Bevel: 45° right 15 x 92 (9/16" x 3-5/8")	 Bevel: 45° left Miter: 45° left/ right 30 x 65 (1-3/16" x 2-9/16") Bevel: 45° right Miter: 45° left/ right 15 x 65 (9/16" x 2-9/16")

**DLS600Z** 165mm (6-1/2")  
RM 4,407

**Cordless Compound Miter Saw**

Gergaji Kompaun Miter Tanpa Kord  
充电式斜断锯



- High accuracy & Lightweight

Standard Equipment: TCT Saw Blade (B-56487), Dust Bag, Vertical Vise, Hex Wrench, Triangular Rule

• Z : Without Charger & Battery



<b>Blade Diameter</b> Diameter Bilah 锯片直径	165mm (6-1/2")
<b>Miter Angle</b> Sudut Miter 斜接角	52°L / 52°R
<b>Bevel Angle</b> Sudut Bevel 斜角	46°L / 46°R
<b>Max Cutting Capacity</b> Kapasiti Pemotongan Maksimum 最大切割能力	90° Miter: 46 x 92mm (1-13/16" x 3-5/8") 45° Miter, L/R: 46 x 65mm (1-13/16" x 2-9/16")
<b>No Load Speed (RPM)</b> Kelajuan Tanpa Beban 回转数	5,000
<b>Dimensions (L x W x H)</b> Dimensi 体积	340x400x440mm (13-3/8"x15-3/4"x17-1/4")
<b>Net Weight</b> Berat Bersih 净重	6.3 - 6.6kg (13.9 - 14.6lbs)
<b>Work Amount (approx.)</b> Jumlah Kerja 工作量	625 pcs with BL1850B Sawing (Round Wood Height 15 x 90mm Thick)

**DLS713RME** | **DLS713Z** 190mm (7-1/2")  
RM 5,048 | RM 3,908

**Cordless Slide Compound Miter Saw**

Gergaji Gelongsor Kompaun Miter Tanpa Kord  
充电式斜断锯 (滑动复合式)



- Powerful Makita-built motor

Standard Equipment: TCT Saw Blade (A-B6147), Vertical Vise, Socket Wrench, Triangular Rule, Dust Bag, Holder Set

• RME: 1x Rapid Charger, 2x 4.0Ah Battery  
• Z: Without Charger & Battery



<b>Blade Diameter</b> Diameter Bilah 锯片直径	190mm (7-1/2")
<b>Miter Angle</b> Sudut Miter 斜接角	47°L / 57°R
<b>Bevel Angle</b> Sudut Bevel 斜角	45°L / 5°R
<b>Max Cutting Capacity</b> Kapasiti Pemotongan Maksimum 最大切割能力	90°: 52 x 300mm (2-1/16" x 11-3/4") 2,200
<b>No Load Speed (RPM)</b> Kelajuan Tanpa Beban 回转数	2,200
<b>Dimensions (L x W x H)</b> Dimensi 体积	655x430x454mm (25-3/4"x17"x17-7/8")
<b>Net Weight</b> Berat Bersih 净重	12.1kg (26.7lbs)
<b>Work Amount (approx.)</b> Jumlah Kerja 工作量	300 pcs with BL1850B Sawing (Merbau Decking 90 x 19mm)

\* All list price shown are for reference only (exclude SST).

\* Semua harga yang ditunjukkan adalah untuk rujukan sahaja (tidak termasuk SST). 所有显示的建议零售价仅供参考 (不包括SST)。

Cordless Target Wood Sander  
LED Flashlight Lampu Sinar LED LED 指示灯  
Vacuum Cleaner Pembersih Vakuum 吸尘器  
Drilling / Fastening Gergaji / Pasak 钻孔 / 紧固  
Impact Drilling / Demolition Gergaji / Pasak 冲击钻孔 / 拆除  
Cutting / Finishing Pemotong / Hiasan 切割  
Grinding / Sanding Pengkilan / Pasak 研磨 / 砂磨  
Sawing / Gergaji 锯切  
Planing / Routing Pengkilan / Tangkapan 刨削 / 锯切  
Others Lain-lain 其他  
Outdoor Power Equipment Alatan Kuasa Luar 户外动力工具





Li-ion Ah 6.0 5.0 4.0 3.0 2.0 1.5

Cordless Target Model 无绳  
LED Flashlight Lampu Suluh LED LED 照明灯  
Vacuum Cleaner Pemilauhi Vakuum 吸尘器  
Drilling / Fastening Dremel / Pengikat 钻头 / 紧固件  
Impact Drilling / Demolition Dremel / Penembok 起工钻头 / 拆墙加工  
Cutting Pemotong 切割  
Grinding / Sanding Pengisar / Pencil 磨削 / 砂磨  
Sawing Cergas 电切  
Planing / Routing Pengisar / Tangkap 刨削 / 雕刻  
Others Lain-lain 其他  
Outdoor Power Equipment Alatan Kerja Luar 园具-户外

**DHS661RFJ DHS661Z** 165mm (6-1/2")  
RM 2,798 RM 1,823

**Cordless Circular Saw**  
Gergaji Piring Tanpa Kord  
充电式圆锯



- Compact and Lightweight Design for Better Maneuverability

Standard Equipment: TCT Saw Blade (B-63018), Hex Wrench, Rip Fence (Guide Rule), Dust Nozzle

- RFJ: 1x Rapid Charger, 2x 3.0Ah Battery, 1x Makpac Connector Box
- Z: Without Charger, Battery & Carrying Case



\*Not applicable for Z model



<b>Blade Diameter</b> Diameter Bilah 锯片直径	165mm (6-1/2")
<b>Hole Diameter</b> Diameter Lubang 孔直径	15.88mm (5/8")   20mm (13/16")
<b>Max Cutting Capacity</b> Kapasiti Pemotongan Maksimum 最大切割能力	90°: 57mm (2-1/4") 45°: 41mm (1-5/8") 50°: 37mm (1-7/16")
<b>No Load Speed (RPM)</b> Kelajuan Tanpa Beban 回转速	5,000
<b>Max Output</b> Keluaran Maksima 最大输出	680W
<b>Dimensions (L x W x H)</b> Dimensi 体积	270x186x250mm (10-5/8"x7-3/8"x9-7/8")
<b>Net Weight</b> Berat Bersih 净重	2.9 - 3.2kg (6.4 - 7.1lbs.)
<b>Work Amount</b> Jumlah Kerja 工作量	200 pcs with BL1850B Sawing with EFFICUT blade, 90° cut SPF 2 x 10 (Thickness 38mm, Width 89mm)

**DHS680RMJ DHS680RFJ DHS680Z** 165mm (6-1/2")  
RM 2,553 RM 2,390 RM 1,415

**Cordless Circular Saw**  
Gergaji Piring Tanpa Kord  
充电式圆锯



- High-efficiency BL motor provides higher power

Standard Equipment: TCT Saw Blade (B-63018), Hex Wrench, Rip Fence (Guide Rule)

- RMJ: 1x Rapid Charger, 2x 4.0Ah Battery, 1x Makpac Connector Box
- RFJ: 1x Rapid Charger, 2x 3.0Ah Battery, 1x Makpac Connector Box
- Z: Without Charger, Battery & Carrying Case



\*Not applicable for Z model



VIDEO CLIP  
Models and specs may vary by country

<b>Blade Diameter</b> Diameter Bilah 锯片直径	165mm (6-1/2")
<b>Max Cutting Capacity</b> Kapasiti Pemotongan Maksimum 最大切割能力	90°: 57mm (2-1/4") 45°: 41mm (1-5/8") 50°: 37mm (1-7/16")
<b>No Load Speed (RPM)</b> Kelajuan Tanpa Beban 回转速	5,000
<b>Dimensions (L x W x H)</b> Dimensi 体积	350x170x238mm (13-3/4"x6-11/16"x9-3/8")
<b>Net weight</b> Berat Bersih 净重	3.0 - 3.3kg (6.6 - 7.3lbs)
<b>Work Amount</b> Jumlah Kerja 工作量	170 pcs with BL1850B Sawing with Standard Blade, 90° cut SPF 2 x 10 (Thickness 38mm, Width 89mm)

**DHS630RME DHS630RFE DHS630Z** 165mm (6-1/2")  
RM 3,785 RM 3,620 RM 2,645

**Cordless Circular Saw**  
Gergaji Piring Tanpa Kord  
充电式圆锯



- Cut up to 66mm thick wood with a single stroke

Standard Equipment: TCT Saw Blade (D-51079), Hex Wrench, Rip Fence (Guide Rule)

- RME: 1x Rapid Charger, 2x 4.0Ah Battery
- RFE: 1x Rapid Charger, 2x 3.0Ah Battery
- Z: Without Charger, Battery & Carrying Case



\*Not applicable for Z model



<b>Blade Diameter</b> Diameter Bilah 锯片直径	165mm (6-1/2")
<b>Max Cutting Capacity</b> Kapasiti Pemotongan Maksimum 最大切割能力	90°: 66mm (2-5/8") 45°: 46mm (1-13/16")
<b>No Load Speed (RPM)</b> Kelajuan Tanpa Beban 回转速	3,100
<b>Dimensions (L x W x H)</b> Dimensi 体积	346x220x247mm (13-5/8"x8-5/8"x9-3/4")
<b>Net weight</b> Berat Bersih 净重	3.0 - 3.4kg (6.6 - 7.5lbs)
<b>Work Amount</b> Jumlah Kerja 工作量	260 pcs with BL1850B Sawing (Mixed Wood 2" x 2")

**DSS610Z** 165mm (6-1/2")  
RM 943

**Cordless Circular Saw**  
Gergaji Piring Tanpa Kord  
充电式圆锯



- Built-in dust blower directs sawdust away from cutting line

Standard Equipment: Carbide-Tipped Saw Blade, Rip Fence (Guide Rule), Hex Wrench

- Z: Without Charger & Battery



<b>Blade Diameter</b> Diameter Bilah 锯片直径	165mm (6-1/2")
<b>Max Cutting Capacity</b> Kapasiti Pemotongan Maksimum 最大切割能力	90°: 0-57mm (2-1/4")/ 45°: 0-40mm (1-9/16") 50°: 0-36mm (1-7/16")
<b>No Load Speed (RPM)</b> Kelajuan Tanpa Beban 回转速	3,700
<b>Dimensions (L x W x H)</b> Dimensi 体积	347x202x228mm (13-5/8"x8"x9")
<b>Net weight</b> Berat Bersih 净重	3.0 - 3.4kg (6.7 - 7.5lbs)
<b>Work Amount</b> Jumlah Kerja 工作量	230 pcs with BL1850B Sawing (Mixed Wood 2" x 2")

**DSS501Z** 136mm (5-3/8")  
RM 908

**Cordless Circular Saw**  
Gergaji Piring Tanpa Kord  
充电式圆锯



- Compact and lightweight design

Standard Equipment: Carbide-Tipped Saw Blade, Hex Wrench, Rip Fence (Guide Rule)

- Z: Without Charger & Battery



<b>Blade Diameter</b> Diameter Bilah 锯片直径	136mm (5-3/8")
<b>Max Cutting Capacity</b> Kapasiti Pemotongan Maksimum 最大切割能力	90°: 51mm (2") 45°: 35mm (1-3/8")
<b>No Load Speed (RPM)</b> Kelajuan Tanpa Beban 回转速	3,600
<b>Dimensions (L x W x H)</b> Dimensi 体积	364x183x201mm (14-3/8"x7-1/4"x7-7/8")
<b>Net Weight</b> Berat Bersih 净重	2.4 - 2.7kg (5.3 - 6.0lbs)
<b>Work Amount</b> Jumlah Kerja 工作量	230 pcs with BL1850B Sawing (Mixed Wood 2" x 2")

\* All list price shown are for reference only (exclude SST).

\* Semua harga yang ditunjukkan adalah untuk rujukan sahaja (tidak termasuk SST). 所有显示的建议零售价仅供参考 (不包括SST)。





Li-ion Ah 6.0 5.0 4.0 3.0 2.0 1.5

**DJR187RME** | **DJR187RFE** | **DJR187Z**  
 RM 2,302 | RM 2,138 | RM 1,163

**Cordless Recipro Saw**  
 Gergaji Resipro Tanpa Kord  
 充电式往复锯



- BL Brushless DC motor with high power

Standard Equipment: Recipro Saw Blades 2pcs (B-05175 & B-05169)

- RME: 1x Rapid Charger, 2x 4.0Ah Battery
- RFE: 1x Rapid Charger, 2x 3.0Ah Battery
- Z: Without Charger, Battery & Carrying Case

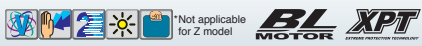

<b>Length of Stroke</b> Panjang Strok 冲程长度	32mm (1-1/4")
<b>Strokes Per Minute (SPM)</b> Kelajuan Strok 冲程速度	High: 0 - 3,000   Low: 0 - 2,300
<b>Capacity</b> Kapasiti 能力	Pipe: 130mm (5-1/8") Wood: 255mm (10")
<b>Dimensions (L x W x H)</b> Dimensi 体积	439x83x231mm (17-1/4"x3-1/4"x9-1/8")
<b>Net Weight</b> Berat Bersih 淨重	3.4 - 3.8kg (7.6 - 8.3lbs)
<b>Work Amount</b> Jumlah Kerja 工作量	65 pcs with BL1850B Cutting (Steel Pipe Ø34 x 3mm)

**DJR188Z**  
 RM 1,050

**Cordless Recipro Saw**  
 Gergaji Resipro Tanpa Kord  
 充电式往复锯



- High cutting speed (Max 3,000 SPM) provide higher cutting efficiency

Standard Equipment: Recipro Saw Blades 2pcs (B-20432 & B-20404)

- Z: Without Charger & Battery



<b>Length of Stroke</b> Panjang Strok 冲程长度	20mm (13/16")
<b>Strokes Per Minute (SPM)</b> Kelajuan Strok 冲程速度	0 - 3,000
<b>Capacity</b> Kapasiti 能力	Pipe : 130mm (5-1/8") Wood: 255mm (10")
<b>Dimensions (L x W x H)</b> Dimensi 体积	BL1815N: 316x81x203mm (12-1/2"x3-3/16"x8") BL1850B: 316x81x220mm (12-1/2"x3-3/16"x8-5/8")
<b>Net Weight</b> Berat Bersih 淨重	2.6 - 2.9kg (5.7 - 6.4lbs)
<b>Work Amount</b> Jumlah Kerja 工作量	58 pcs with BL1850B Cutting (Steel Pipe Ø34 x 3mm)

**DJR186RME** | **DJR186RFE** | **DJR186Z**  
 RM 2,043 | RM 1,880 | RM 905

**Cordless Recipro Saw**  
 Gergaji Resipro Tanpa Kord  
 充电式往复锯



- Toolless blade change; redesign of blade clamp makes it easier to remove a blade

Standard Equipment: Recipro Saw Blades 2pcs (B-05175 & B-05169)

- RME: 1x Rapid Charger, 2x 4.0Ah Battery
- RFE: 1x Rapid Charger, 2x 3.0Ah Battery
- Z: Without Charger, Battery & Carrying Case



<b>Length of Stroke</b> Panjang Strok 冲程长度	32mm (1-1/4")
<b>Strokes Per Minute (SPM)</b> Kelajuan Strok 冲程速度	0 - 2,800
<b>Capacity</b> Kapasiti 能力	Pipe : 130mm (5-1/8") Wood: 255mm (10")
<b>Dimensions (L x W x H)</b> Dimensi 体积	486x81x223mm (19-1/8"x3-3/16"x8-3/4")
<b>Net Weight</b> Berat Bersih 淨重	3.5 - 3.8kg (7.6 - 8.3lbs)
<b>Work Amount</b> Jumlah Kerja 工作量	60 pcs with BL1850B Cutting (Steel Pipe Ø34 x 3mm)

**DJR181RFE**  
 RM 1,853

**Cordless Recipro Saw**  
 Gergaji Resipro Tanpa Kord  
 充电式往复锯



- Toolless blade change system enables fast, one-handed blade changes

Standard Equipment: Recipro Saw Blade

- RFE: 1x Rapid Charger, 2x 3.0Ah Battery



<b>Length of Stroke</b> Panjang Strok 冲程长度	28mm (1-1/8")
<b>Strokes Per Minute (SPM)</b> Kelajuan Strok 冲程速度	0 - 2,900
<b>Capacity</b> Kapasiti 能力	Pipe : 130mm (5-1/8") Wood: 255mm (10")
<b>Dimensions (L x W x H)</b> Dimensi 体积	499x91x234mm (19-5/8"x3-5/8"x9-1/4")
<b>Net Weight</b> Berat Bersih 淨重	3.5kg (7.7lbs)
<b>Work Amount</b> Jumlah Kerja 工作量	70 pcs with BL1850B Cutting (SPF Material 2x10")

**DJR183Z**  
 RM 952

**Cordless Recipro Saw**  
 Gergaji Resipro Tanpa Kord  
 充电式往复锯



- Dual-position on/off switch allows for either paddle or trigger switch operation

Standard Equipment: Recipro Saw Blades 2pcs

- Z: Without Charger & Battery



<b>Capacity</b> Panjang Strok 冲程长度	Pipe : 50mm (2") Wood: 50mm (2")
<b>Length of Stroke</b> Kelajuan Strok 冲程速度	13mm (1/2")
<b>Strokes Per Minute (SPM)</b> Kapasiti 能力	0-3,000
<b>Dimensions (L x W x H)</b> Dimensi 体积	392x81x209mm (15-1/2"x3-3/16"x8-1/4")
<b>Net weight</b> Berat Bersih 淨重	1.5 - 1.7kg (3.3 - 3.8lbs)
<b>Work Amount</b> Jumlah Kerja 工作量	56 pcs with BL1850B Cutting (SPF Material 2x10")

\* All list price shown are for reference only (exclude SST).

\* Semua harga yang ditunjukkan adalah untuk rujukan sahaja (tidak termasuk SST). 所有显示的建议零售价仅供参考 (不包括SST)。

**Cordless**  
Terdapat Model Lain

**LED Flashlight**  
Lampu Saku LED  
LED 手电筒

**Vacuum Cleaner**  
Pembersih Vakuum  
吸尘器

**Drilling / Fastening**  
Gergaji / Pasak  
电钻 / 螺絲

**Impact Drilling / Demolition**  
Gergaji / Pasak  
电钻 / 螺絲

**Cutting**  
Pemotong  
切刀

**Grinding / Sanding**  
Pengkilan / Pasak  
砂磨 / 螺絲

**Sawing**  
Gergaji  
锯

**Planing / Routing**  
Pengkilan / Pasak  
电钻 / 螺絲

**Others**  
Lain-lain  
其他

**Outdoor Power Equipment**  
Alatan Kerja Luar  
园具 / 户外

18V

LXT

Li-ion Ah 6.0 | 5.0 | 4.0 | 3.0 | 2.0 | 1.5

# Cordless Jig Saw

Gergaji Jig Tanpa Kord 充电式线锯机

## As Powerful As Coded Jigsaws

Berkuasa seperti Jig Saw berkord 相当于有线线锯机的强力



**DJV182RME** | **DJV182RFE** | **DJV182Z**  
RM 2,615 | RM 2,452 | RM 1,477

### Cordless Jig Saw

Gergaji Jig Tanpa Kord  
充电式线锯机



- Powerful Brushless DC motor

**Standard Equipment:** Jig Saw Blade Set  
(No. BR-10, BR-13, B-22, 2pcs each), Cover Plate,  
Anti-Splintering Device, Hex Wrench

- RME: 1x Rapid Charger, 2x 4.0Ah Battery
- RFE: 1x Rapid Charger, 2x 3.0Ah Battery
- Z: Without Charger, Battery & Carrying Case



\*Not applicable  
for Z model



VIDEO CLIP  
Models and specs  
may vary by country

DJV181/DJV182

**DJV181RFE** | **DJV181Z**  
RM 2,452 | RM 1,477

### Cordless Jig Saw

Gergaji Jig Tanpa Kord  
充电式线锯机



- Excellent performance provides higher productivity

**Standard Equipment:** Jig Saw Blade Set  
(No. BR-10, BR-13, B-22, 2pcs each),  
Cover Plate, Anti-Splintering Device, Hex Wrench

- RFE: 1x Rapid Charger, 2x 3.0Ah Battery
- Z: Without Charger, Battery & Carrying Case



\*Not applicable  
for Z model



VIDEO CLIP  
Models and specs  
may vary by country

DJV181/DJV182

**DJV180RFE** | **DJV180Z**  
RM 2,188 | RM 1,212

440

### Cordless Jig Saw

Gergaji Jig Tanpa Kord  
充电式线锯机



- Low vibration and low noise

**Standard Equipment:** Jig Saw Blade Set  
(No. BR-10, BR-13, B-22, 2pcs each), Cover Plate,  
Anti-Splintering Device, Hex Wrench

- RFE: 1x Rapid Charger, 2x 3.0Ah Battery
- Z: Without Charger, Battery & Carrying Case



\*Not applicable  
for Z model



**DSD180Z**  
RM 1,468

### Cordless Drywall Saw

Gergaji Drywall Tanpa Kord  
充电式石膏板切割器



- Ideal for cutting holes in drywalls when setting  
ceiling lights, air vents etc

**Standard Equipment:** Blade, Blade Cover,  
Base Cover, Hex Wrench

- Z: Without Charger & Battery



VIDEO CLIP  
Models and specs  
may vary by country

DSD180

<b>Capacity</b> Kapasiti 能力	Wood: 135mm (5-5/16") Steel: 10mm (3/8") 26mm (1")
<b>Length of Stroke</b> Panjang Strok 冲程长度	
<b>Strokes Per Minute (SPM)</b> Kelajuan Strok 冲程速度	800 - 3,500
<b>Dimensions (L x W x H)</b> Dimensi 体积	266x77x208mm (10-1/2"x3"x8-3/16")
<b>Net Weight</b> Berat Bersih 净重	2.4 - 2.7kg (5.2 - 5.9lbs)
<b>Work Amount</b> Jumlah Kerja 工作量	266 pcs with BL1850B Sawing with Blade B-10 Plywood (Thickness 12mm x Length 300mm)

<b>Capacity</b> Kapasiti 能力	Wood: 135mm (5-5/16") Steel: 10mm (3/8") 26mm (1")
<b>Length of Stroke</b> Panjang Strok 冲程长度	
<b>Strokes Per Minute (SPM)</b> Kelajuan Strok 冲程速度	800 - 3,500
<b>Dimensions (L x W x H)</b> Dimensi 体积	298x77x189mm (11-3/4"x3"x7-7/16")
<b>Net Weight</b> Berat Bersih 净重	2.3 - 2.6kg (5.0 - 5.7lbs)
<b>Work Amount</b> Jumlah Kerja 工作量	266 pcs with BL1850B Sawing with Blade B-10 Plywood (Thickness 12mm x Length 300mm)

<b>Capacity</b> Kapasiti 能力	Wood: 135mm (5-5/16") Steel: 10mm (3/8") 26mm (1")
<b>Length of Stroke</b> Panjang Strok 冲程长度	
<b>Strokes Per Minute (SPM)</b> Kelajuan Strok 冲程速度	0-2,600
<b>Dimensions (L x W x H)</b> Dimensi 体积	257x73x208mm (10-1/8"x2-7/8"x8-3/16")
<b>Net Weight</b> Berat Bersih 净重	2.7 - 3.0kg (6.0 - 6.7lbs)
<b>Work Amount</b> Jumlah Kerja 工作量	216 pcs with BL1850B Sawing with Blade B-10 Plywood (Thickness 12mm x Length 300mm)

<b>Strokes Per Minute (SPM)</b> Kelajuan Strok 冲程速度	0 - 6,000
<b>Length of Stroke</b> Panjang Strok 冲程长度	6mm (1/4")
<b>Capacity</b> Kapasiti 能力	Drywall: 30mm (1-3/16") Wood: 15mm (9/16")
<b>Dimensions (L x W x H)</b> Dimensi 体积	263x79x291mm (10-3/8"x3-1/8"x11-3/8")
<b>Net weight</b> Berat Bersih 净重	1.7 - 2.0kg (3.8 - 4.5lbs)
<b>Work Amount</b> Jumlah Kerja 工作量	360 m with BL1850B Cutting (Gypsum Board Thickness 12.5mm/1ply)

\* All list price shown are for reference only (exclude SST).

\* Semua harga yang ditunjukkan adalah untuk rujukan sahaja (tidak termasuk SST). 所有显示的建议零售价仅供参考 (不包括SST)。

Cordless  
Target Kord 无绳式

LED Flashlight  
Lampu Suluh LED  
LED 手电筒

Vacuum Cleaner  
Pembersih Vakuum  
吸尘器

Drilling / Fastening  
Drauli / Pasang  
钻孔 / 紧固

Impact Drilling / Demolition  
Drauli / Penembak  
起工钻孔 / 拆除加工

Cutting  
Pemotong  
切割

Grinding / Sanding  
Pengisar / Pasah  
磨削 / 砂磨

Sawing  
Gergaji  
锯切

Planing / Routing  
Pengisar / Tangkai  
刨削 / 雕刻

Others  
Lain-lain  
其他

Outdoor Power Equipment  
Alatan Kerja Luar  
园具-户外

Makita  
MAKITA



# Cordless Planer

Pengetam Tanpa Kord 充电式电刨

**Work Amount**  
with BL1850B  
(0.5mm Cutting Depth)

**76m**  
(approx.)

\*Jumlah Kerja 工作量  
Actual performance may vary based on application.  
Masa Penggunaan Berterusan/ Jumlah Kerja: Prestasi sebenar  
— bergantung berbeza mengikut aplikasi  
连续使用时间/ 工作量: 实际表现可能因应用情况而异。

**Planing Width**  
Lebar Pengetaman 刨削宽度

**82mm**

**Ergonomically designed and rubberized handle**

Pemegang getah yang direka secara ergonomik meningkatkan keselesaan  
符合人体工程学的橡胶柔软握柄

**Knob with click stops**

Tombol pelarasan 调节旋钮

**Rigid aluminium die-cast bracket**

Pendakap die-casting aluminium  
高刚性铝压铸支架

**Foot on base plate**

protects workpiece and blade from scratches and damages even if the machine is put on workpiece before drum comes to a complete halt

Kaki boleh maningkatkan plat asas untuk melindungi bilah dan benda kerja, mengelakkan calar dan kerosakan  
支脚可抬高底座保护刨刀和工作, 可防止刮伤和损坏



**Front base with 3 chamfering grooves**

Planer depan menyediakan tiga alur berbentuk V yang berlainan  
前刨板有3个V型槽提供三个不同的凹槽

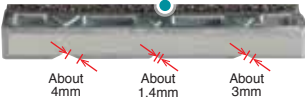

**DKP181RTJ** **DKP181Z** 82mm (3-1/4")  
RM 3,425 RM 2,140

**Cordless Planer**  
Pengetam Tanpa Kord  
充电式电刨

• Auto-start Wireless System (AWS) connects to vacuum cleaner with Bluetooth

Standard Equipment: Planer Blade, Blade Gauge, Guide Rule, Depth Guide, Socket Wrench, Sharpening Holder Assembly (for resharpenable blade)

• RTJ: 1x Rapid Charger, 2x 5.0Ah Battery, 1x Makpac Connector Box  
• Z: Without Charger, Battery & Carrying Case



\*Not applicable for Z model



<b>Planing Width</b> Lebar Pelan 刨削宽度	82mm (3-1/4")
<b>Planing Depth</b> Kedalaman Pelan 刨削深度	3mm (1/8")
<b>No Load Speed (RPM)</b> Kelajuan Tanpa Beban 回转速数	12,000
<b>Dimensions (L x W x H)</b> Dimensi 体积	366x156x166mm (13-3/8"x6-1/8"x6-1/2")
<b>Net Weight</b> Berat Bersih 净重	3.3 - 3.6kg (7.3 - 7.9lbs.)

**DKP180RFE** **DKP180Z** 82mm (3-1/4")  
RM 2,052 RM 1,075

**Cordless Planer**  
Pengetam Tanpa Kord  
充电式电刨

• Easy blade setting system for fast blade installation

Standard Equipment: Planer Blade, Blade Gauge, Guide Rule, Socket Wrench

• RFE: 1x Rapid Charger, 2x 3.0Ah Battery  
• Z: Without Charger, Battery & Carrying Case



\*Not applicable for Z model



<b>Planing Width</b> Lebar Pelan 刨削宽度	82mm (3-1/4")
<b>Planing Depth</b> Kedalaman Pelan 刨削深度	2.0mm (5/64")
<b>No Load Speed (RPM)</b> Kelajuan Tanpa Beban 回转速数	14,000
<b>Dimensions (L x W x H)</b> Dimensi 体积	333x157x160mm (13-1/8"x6-3/16"x6-5/16")
<b>Net weight</b> Berat Bersih 净重	3.2 - 3.5kg (7.1 - 7.9lbs)
<b>Work Amount</b> Jumlah Kerja 工作量	91 m with BL1850B Wood Thickness 1mm

\* All list price shown are for reference only (exclude SST).

\* Semua harga yang ditunjukkan adalah untuk rujukan sahaja (tidak termasuk SST). 所有显示的建议零售价仅供参考 (不包括SST)。

- Cordless Targeted Jobs
- LED Flashlight Lampu Suhu LED LED 照明灯
- Vacuum Cleaner Pembunuh Vakuum 吸尘器
- Drilling / Fastening Cukut / Pengikat 钻孔 / 紧固
- Impact Drilling / Demolition Cukut / Penusuk 冲击钻孔 / 冲击施工
- Cutting Pemotong 切割
- Grinding / Sanding Pengisar / Pechin 研磨 / 砂磨
- Sawing Gergaji 锯切
- Planing / Routing Pengisar / Tunggam 刨削 / 雕刻
- Others Lain-lain 其他
- Outdoor Power Equipment Alatan Kuat Luar 户外动力工具





Li-ion Ah 6.0 5.0 4.0 3.0 2.0 1.5

## DPJ180Z

RM 1,232

430

### Cordless Plate Joiner

Mesin Kayu Tanpa Kord  
充电式木工接合机

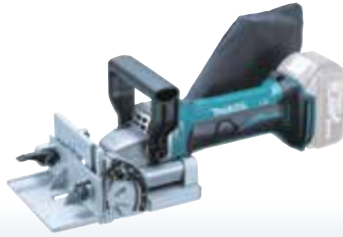

- Easy blade setting system for fast blade installation

Standard Equipment: Cutter Blade, Angle Guide, Lock Nut Wrench, Set Plate, Dust Bag

- Z: Without Charger & Battery



## DCO180Z 6.35mm (1/4")

RM 662

430

### Cordless Cut-Out Tool

Mesin Pemotong Tanpa Kord  
充电式石膏板开孔机



- Accepts both 1/8" and 1/4" bits

Standard Equipment: Drywall Guide Bit x2, Collet Nut, Collet Cone 6.35mm (1/4")

- Z: Without Charger & Battery



## DVP180Z

RM 2,632

### Cordless Vacuum Pump

Pam Vakum Tanpa Kord  
充电式真空泵



- For air purge during installation of room air conditioner

Standard Equipment: Vacuum Pump Oil, Adapter

- Z: Without Charger & Battery

## DRT50Z | DRT50ZJX9 6mm (1/4"), 8mm (3/8")

RM 1,192

RM 2,127

### Cordless Trimmer

Mesin Perapi Tanpa Kord  
充电式修边机



DRT50

VIDEO CLIP  
Models and specs may vary by country



Trimmer Base Assembly  
For DRT50ZJX9 only



- Faster Trimming than Corded

Standard Equipment: Trimmer Base Assembly (196612-6), Collet Cone, Dust Nozzle, Straight Guide Assembly, Wrench x2

- Z : Without Charger, Battery & Carrying Case
- ZJX9: Tilt Base Assembly (195561-4), Plunge Base Assembly (195563-0), Side Grip, Templet Guide, Guide Rail Adapter Set, Guide Holder Set, Makpac Connector Box, Without Charger & Battery

\*Not applicable for Z model



<b>Blade Diameter</b> Diameter Bilah 锯片直径	100mm (4")
<b>Max Cutting Depth</b> Kedalaman Pemotongan Maksimum 最大切割深度	20mm (3/4")
<b>No Load Speed (RPM)</b> Kelajuan Tanpa Beban 回转数	6,500
<b>Dimensions (L x W x H)</b> Dimensi 体积	351x139x149mm (13-3/4"x5-1/2"x5-7/8")
<b>Net weight</b> Berat Bersih 淨重	2.8 - 3.1kg (6.2 - 6.8lbs)
<b>Work Amount</b> Jumlah Kerja 工作量	333 pcs with BL1850B Biscuit (60 x 23 x 4) Cutting Slot 12.3mm

<b>Capacity</b> Kapasiti 能力	Collet : 3.18mm (1/8") or 6.35mm (1/4")
<b>No Load Speed (RPM)</b> Kelajuan Tanpa Beban 回转数	30,000
<b>Dimensions (L x W x H)</b> Dimensi 体积	296x77x118mm (11-5/8"x3"x4-5/8")
<b>Net weight</b> Berat Bersih 淨重	1.5 - 1.8kg (3.3 - 4.0lbs)
<b>Work Amount</b> Jumlah Kerja 工作量	225 m with BL1850B 6.35mm Bit Cutting Plaster Board 1.2 x 800mm

<b>Flow Rate</b> Kadar Aliran 流量	50L/min
<b>Ultimate Vacuum</b> Tahap Maksimum Vakum 最大真空度	20Pa (150 microns)
<b>Motor Speed</b> Kelajuan Motor 马达速度	3,840min <sup>-1</sup>
<b>Oil Tank Capacity</b> Kapasiti Tangki Minyak 润滑油箱	115mL
<b>Inlet Port</b> Pelabuhan Inlet 进气管直径	5/16"
<b>Dimensions (L x W x H)</b> Dimensi 体积	265x93x175mm (10-3/8"x3-5/8"x6-7/8")
<b>Net Weight</b> Berat Bersih 淨重	3.5kg
<b>Continuous Usage Time</b> Masa Penggunaan Berterusan 连续使用时间	50 min with BL1850B

<b>Collet Capacity</b> Kapasiti Collet 夹头直径	6mm, 8mm or 1/4", 3/8"
<b>No Load Speed (RPM)</b> Kelajuan Tanpa Beban 回转数	10,000 - 30,000
<b>Plunge Capacity</b> Kapasiti Plunge 能力	Trimmer Base: 0 - 40mm (0" - 1-9/16") Plunge Base: 0 - 35mm (0" - 1-3/8")
<b>Dimensions (L x W x H)</b> Dimensi 体积	134x89x226mm (5-1/4"x3-1/2"x8-7/8")
<b>Net Weight</b> Berat Bersih 淨重	1.8 - 2.1kg (3.9 - 4.6lbs)
<b>Work Amount</b> Jumlah Kerja 工作量	83 m with BL1850B Routing Ø6 x 4mm



## Trimmer Base Assembly (Optional)

Trimmer Base  
Part No. 196612-6



Plunge Base  
Part No. 195563-0  
(Optional)



Tilt Base  
Part No. 195561-4  
(Optional)

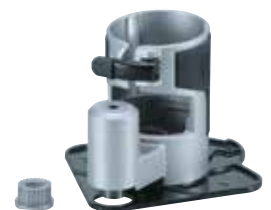

Offset Base  
Part No. 196922-1  
(Optional)

\* All list price shown are for reference only (exclude SST).

\* Semua harga yang ditunjukkan adalah untuk rujukan sahaja (tidak termasuk SST). 所有显示的建议零售价仅供参考 (不包括SST)。





# Cordless Brad Nailer

Mesin Pemaku Tanpa Kord 充电式打钉机

**Work Amount**  
with BL1850B  
(18Ga Brad Nail)

**4,000 pcs**  
(approx.)

\* Continuous Usage Time/ Work Amount:  
Actual performance may vary based on application.  
Masa Penggunaan Berterusan/ Jumlah Kerja: Prestasi sebenar  
mungkin berbeza mengikut aplikasi.  
连续使用时间/ 工作量: 实际表现可能因应用情况而异。



**Nail outlet port placed in the center of the contact top**  
allows for easy aiming for precision nail placement  
Pelabuhan keluar kuku yang diletakkan di tengah bahagian sentuhan membolehkan memudahkan penempatan paku ketepatan yang mudah  
位于接触顶部中心的钉子出口允许容易地瞄准精确的钉子放置



## DFN350Z

RM 3,672

**Cordless Brad Nailer**  
Mesin Pemaku Tanpa Kord  
充电式打钉机



• Ideal for Light Duty Applications such as Fastening Chamfer Strip to Concrete Form Plywood Wall

Standard Equipment: Safety Goggles, Nose Adapter, Hex Wrench, Belt Clip

• Z : Without Charger & Battery



<b>Capacity</b> Kapasiti 能力	Length: 15 - 35mm (5/8" - 1-3/8")
<b>Magazine Capacity</b> Bilangan Staples 装钉个数	Gauge: 18Ga
<b>Dimensions (L x W x H)</b> Dimensi 体积	257x79x228mm (10-1/8"x3-1/8"x9")
<b>Net Weight</b> Berat Bersih 净重	2.1 - 2.4kg (4.6 - 5.3lbs.)
<b>Work Amount (approx.)</b> Jumlah Kerja 工作量	4000pcs with BL1850B

Accessories (optional)			
Description	Size	Pcs/ Box	Part No.
Brad Nail 15mm (5/8")	F15	5,000	B-04307
Brad Nail 20mm (3/4")	F20	5,000	B-04313
Brad Nail 25mm (1")	F25	5,000	B-04329
Brad Nail 30mm (1-3/16")	F30	5,000	B-04335
Brad Nail 35mm (1-3/8")	F35	5,000	B-04357

## DPT353Z

RM 2,560

**Cordless Pin Nailer**  
Mesin Pemaku Tanpa Kord  
充电式打钉机

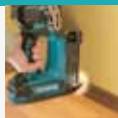

• Shoots 6,400 nails on a single full BL1860B charge

Standard Equipment: Nose Adapter, Safety Goggles, Belt Clip

• Z : Without Charger & Battery



<b>Capacity</b> Staple 钉种	Length: 15, 18, 25, 30, 35mm (5/8", 11/16", 1", 1-3/16", 1-3/8")
<b>Magazine Capacity</b> Bilangan Staples 装钉个数	Dia.: 0.6mm (1/32")
<b>Dimensions (L x W x H)</b> Dimensi 体积	Gauge: 23Ga
<b>Net Weight</b> Berat Bersih 净重	120
<b>Work Amount (approx.)</b> Jumlah Kerja 工作量	257x79x226mm (9-7/8"x3-5/8"x8-7/8")
	2.0 - 2.3kg (4.4 - 5.1lbs)
	5300 pcs Pin Nail with BL1850B

Accessories (optional)			
Description	Size	Pcs/ Box	Part No.
Pin Nail 18mm (11/16")	P18	10,000	F-31825
Pin Nail 25mm (1")	P25	10,000	F-31838
Pin Nail 30mm (1-3/16")	P30	10,000	F-31841
Pin Nail 35mm (1-3/8")	P35	10,000	F-31854

## DST221Z

RM 1,983

**Cordless Stapler**  
Stapler Tanpa Kord  
充电式钉枪



• Compact and powerful stapler can drive a wide range of 10mm staple lengths

Standard Equipment: Safety Goggles, Hook

• Z : Without Charger & Battery



<b>Staple</b> Staple 钉种	Width: 10mm (3/8")
<b>Magazine Capacity</b> Bilangan Staples 装钉个数	Length: 10, 13, 16, 19, 22mm (3/8", 1/2", 5/8", 3/4", 7/8")
<b>Dimensions (L x W x H)</b> Dimensi 体积	Gauge: 0.6 x 1.2mm (1/32" x 1/16")
<b>Net Weight</b> Berat Bersih 净重	98
<b>Work Amount (approx.)</b> Jumlah Kerja 工作量	251x91x212mm (9-7/8"x3-5/8"x8-3/8")
	2.1 - 2.4kg (4.7 - 5.3lbs)
	3000 pcs with BL1850B Stapler Width 10mm

Accessories (optional)			
Description	Length	Pcs/ Box	Part No.
Staple 1010HD	10mm (3/8")	5,040	F-32647
Staple 1013HD	13mm (1/2")	5,040	F-32650
Staple 1016HD	16mm (5/8")	5,040	F-32663
Staple 1019HD	19mm (3/4")	5,040	F-32676
Staple 1022HD	22mm (7/8")	5,040	F-32689

\* All list price shown are for reference only (exclude SST).

\* Semua harga yang ditunjukkan adalah untuk rujukan sahaja (tidak termasuk SST). 所有显示的建议零售价仅供参考 (不包括SST)。

**Cordless**  
Target: 无绳工具

**LED Flashlight**  
Lampu Suluh LED  
LED手电筒

**Vacuum Cleaner**  
Pembersih Vakuum  
吸尘器

**Drilling / Fastening**  
Gergaji / Pengikat  
电钻 / 紧固件

**Impact Drilling / Demolition**  
Gergaji / Pemusnah  
电钻 / 冲击工具

**Cutting**  
Pemotong  
切割机

**Grinding / Sanding**  
Pengkilan / Pemoles  
砂轮机 / 砂纸

**Sawing**  
Gergaji  
锯切

**Planing / Routing**  
Pengkilan / Tumpang  
刨板 / 压板

**Others**  
Lain-lain  
其他

**Outdoor Power Equipment**  
Alatan Kuat Luar  
园机 / 户外



# Cordless Hedge Trimmer

Pemangkas Tanaman Pagar Tanpa Kord 充电式篱笆修剪机

**Chip receiver**  
Suis Pemicu 扳机开关

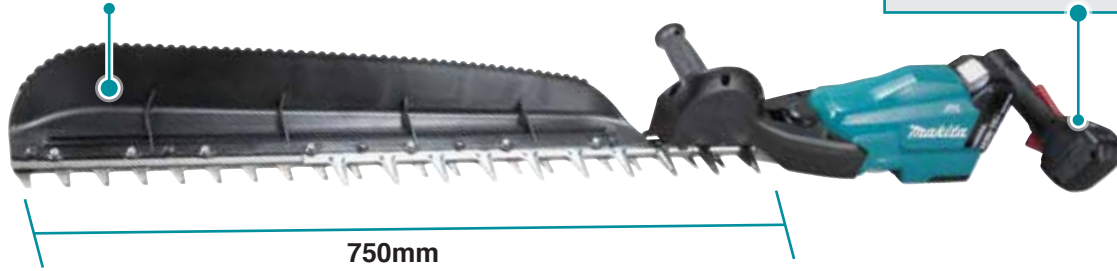

**3-speed**

- High : 4,400 SPM
- Medium : 3,600 SPM
- Low : 2,000 SPM

**Light weight**  
Ringan 轻量

**3.9kg**  
with BL1850B 5.0Ah Battery

## Optimum blade shape for smooth cutting

Bentuk optimum bilah untuk pemotongan licin 最佳刀片形状，可平滑切割

**Sharp edge blades:**  
Bilah tajam 锋利的刀刃  
Upper blade...curving downward  
Lower blade...curving upward

Contact point is only both tips  
接触点只是两个提示

**Twigs are caught easily and held firmly**  
Ranting ditangkap dengan mudah dan dipegang dengan kuat 树枝很容易被抓住并坚定地坚持

## Reverse rotation system

Sistem putaran terbalik 反转系统

for freeing the blade when it is jammed by thick branches

Sistem putaran terbalik untuk membebaskan bilah apabila ia tersekat oleh dahan tebal 反转系统当刀片被粗大的树枝堵塞时释放刀片

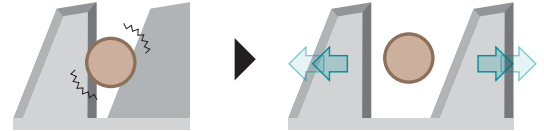

**DUH754SRT** | **DUH754SZ** 750mm (29-1/2")  
RM 4,275 | RM 3,463

**Cordless Hedge Trimmer**  
Pemangkas Tanaman Pagar Tanpa Kord  
充电式篱笆修剪机



- Excellent balance of high power and lightweight

**Standard Equipment:** Blade Cover, Chip Receiver, Safety Goggles

- RT: 1x Rapid Charger, 1x 5.0Ah Battery
- Z: Without Charger & Battery



<b>Blade Length</b> Panjang bilah 刀片长度	750mm (29-1/2")
<b>Strokes Per Minute (SPM)</b> Kelajuan Strok 冲程速度	High: 4,400   Med: 3,600   Low: 2,000
<b>Tooth Spacing</b> Selang Gigi 牙齿间隔	35mm (1-3/8")
<b>Max Cutting Capacity</b> Kapasiti Pemotongan Maksimum 最大切割能力	23.5mm (15/16")
<b>Dimensions (L x W x H)</b> Dimensi 体积	1,200x282x143mm (47-1/4"x11-1/8"x5-5/8")
<b>Net Weight</b> Berat Bersih 净重	3.4 - 3.9kg (7.5 - 8.6lbs.)
<b>Continuous Usage Time (approx.)</b> Masa Penggunaan Berterusan 连续使用时间	High: 54min   Med: 66min   Low: 158min with BL1850B

**DUH601Z** 600mm (23-5/8")  
RM 1,905

**Cordless Hedge Trimmer**  
Pemangkas Tanaman Pagar Tanpa Kord  
充电式篱笆修剪机



- 5-Position rotating rear handle for increased comfort during vertical and angle trimming

**Standard Equipment:** Blade Cover, Safety Goggles

- Z: Without Charger & Battery



QR Code and VIDEO CLIP icon for DUH601. Models and specs may vary by country.

<b>Blade Length</b> Panjang bilah 刀片长度	600mm (23-5/8")
<b>Strokes Per Minute (SPM)</b> Kelajuan Strok 冲程速度	High: 0 - 4,400   Med: 0 - 3,600   Low: 0 - 2,000
<b>Max Cutting Capacity</b> Kapasiti Pemotongan Maksimum 最大切割能力	23.5mm (15/16")
<b>Tooth Spacing</b> Selang Gigi 牙齿间隔	35mm (1 - 3/8")
<b>Dimensions (L x W x H)</b> Dimensi 体积	1,121x192x225mm (44-1/8"x7-1/2"x8-7/8")
<b>Net Weight</b> Berat Bersih 净重	3.8 - 4.5kg (8.4 - 9.8lbs.)
<b>Continuous Usage Time (approx.)</b> Masa Penggunaan Berterusan 连续使用时间	High - 45min   Low - 165min with BL1850B

**DUH523RME** | **DUH523RFE** | **DUH523Z** 520mm (20-1/2")  
RM 1,868 | RM 1,705 | RM 730

**Cordless Hedge Trimmer**  
Pemangkas Tanaman Pagar Tanpa Kord  
充电式篱笆修剪机



- Delivers 2,700 SPM for increased cutting speed

**Standard Equipment:** Blade Cover

- RME: 1x Rapid Charger, 2x 4.0Ah Battery
- RFE: 1x Rapid Charger, 2x 3.0Ah Battery
- Z: Without Charger & Battery



<b>Blade Length</b> Panjang bilah 刀片长度	520mm (20-1/2")
<b>Strokes Per Minute (SPM)</b> Kelajuan Strok 冲程速度	2,700
<b>Tooth Spacing</b> Selang Gigi 牙齿间隔	26mm (1")
<b>Dimensions (L x W x H)</b> Dimensi 体积	938x195x193mm (37"x7-5/8"x7-5/8")
<b>Max Output</b> Keluasan Maksima 最大输出	210W
<b>Net Weight</b> Berat Bersih 净重	3.0 - 3.4kg (6.7 - 7.5lbs)
<b>Continuous Usage Time (approx.)</b> Masa Penggunaan Berterusan 连续使用时间	130 min with BL1850B

\* All list price shown are for reference only (exclude SST).

\* Semua harga yang ditunjukkan adalah untuk rujukan sahaja (tidak termasuk SST). 所有显示的建议零售价仅供参考 (不包括SST)。

Cordless Target Kord 无绳  
LED Flashlight Lampu Suluh LED LED 照明灯  
Vacuum Cleaner Pembersih VAKUUM 吸尘器  
Drilling / Fastening Dronat / Pengikat 钻头 / 螺帽  
Impact Drilling / Demolition Dronat / Pemusnah 起工钻头 / 拆墙加工  
Cutting Pemotong 切割  
Grinding / Sanding Pengisar / Pechin 磨削 / 砂磨  
Sawing Gergaji 电锯  
Planing / Routing Pengisar / Tangkapan 刨削 / 雕刻  
Others Lain-lain 其他  
Outdoor Power Equipment Alatan Keras Luar 园具-户外





# Cordless Hedge Trimmer

Pemangkas Tanaman Pagar Tanpa Kord 充电式篱笆修剪机

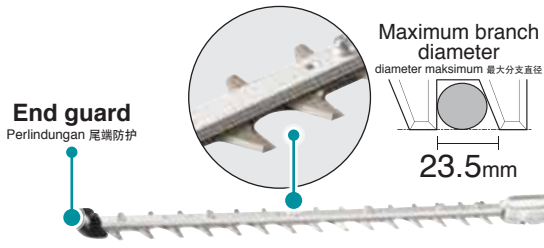

**Shoulder harness can be attached**  
Tali bahu boleh disambung 可连接肩带

Tali bahu boleh disambung 可连接肩带

**The angle of hedge trimmer head can be changed simply by operating a lever**

Sudut kepala pemangkas lindung nilai dapat diubah hanya dengan menggunakan tuas  
绿篱机刀头的角度可以通过操作杠杆来简单地改变

**Light Weight**  
Ringan 轻量  
**3.9kg**  
with BL1815N  
1.5Ah Battery

## DUN500WZ 500mm (19-3/4")

Price TBA

**Cordless Hedge Trimmer**  
Pemangkas Tanaman Pagar Tanpa Kord  
充电式篱笆修剪机



- Lightweight for reduced operator fatigue

Standard Equipment: Blade Cover, Band Assembly

• Z: Without Charger & Battery



<b>Blade Length</b> Panjang bilah 刀片长度	500mm (19-3/4")
<b>Strokes Per Minute (SPM)</b> Kelajuan Strok 冲程速度	High: 4,400   Med: 3,600   Low: 2,000
<b>Tooth Spacing</b> Selang Gigi 牙齿间隔	35mm (1-3/8")
<b>Max Cutting Capacity</b> Kapasiti Pemotongan Maksimum 最大切割能力	23.5mm (15/16")
<b>Dimensions (L x W x H)</b> Dimensi 体积	2,115x97x137mm (83-1/4"x3-13/16"x5-3/8")
<b>Net Weight</b> Berat Bersih 净重	3.9 - 4.3kg (8.6 - 9.5lbs.)
<b>Continuous Usage Time (approx.)</b> Masa Penggunaan Berterusan 连续使用时间	High: 50min   Med: 75min   Low: 150min with BL1850B

## DUN600LZ 600mm (23-5/8")

Price TBA

**Cordless Hedge Trimmer**  
Pemangkas Tanaman Pagar Tanpa Kord  
充电式篱笆修剪机



- Lightweight for reduced operator fatigue

Standard Equipment: Blade Cover, Hex Wrench

• Z: Without Charger & Battery



<b>Blade Length</b> Panjang bilah 刀片长度	600mm (23-5/8")
<b>Strokes Per Minute (SPM)</b> Kelajuan Strok 冲程速度	High: 4,400   Med: 3,600   Low: 2,000
<b>Tooth Spacing</b> Selang Gigi 牙齿间隔	35mm (1-3/8")
<b>Max Cutting Capacity</b> Kapasiti Pemotongan Maksimum 最大切割能力	23.5mm (15/16")
<b>Dimensions (L x W x H)</b> Dimensi 体积	2,050x230x178mm (80-1/2"x9"x7")
<b>Net Weight</b> Berat Bersih 净重	3.7 - 4.1kg (8.2 - 9.0lbs.)
<b>Continuous Usage Time (approx.)</b> Masa Penggunaan Berterusan 连续使用时间	High: 45min   Med: 66min   Low: 150min with BL1850B

## DUR190LRT2

Price TBA

**Cordless Grass Trimmer**  
Pemotong Rumput Tanpa Kord  
充电式割草机



- lightweight and powerful cutting performance

Standard Equipment: Plastic Blade, Safety Goggles, Band Assembly, Accessory Bag, Hex Wrench

• RT2: 1x Rapid Charger, 2x 5.0Ah Battery



<b>Cutting Width</b> Lebar Keratan 切割宽度	Trimmer Head: 300mm (11-3/4") Metal Blade: 230mm (9") Plastic Blade: 255mm (10")
<b>No Load Speed (RPM)</b> Kelajuan Tanpa Beban 回转数	3,500 - 6,000
<b>Spindle Size</b> Saiz Spinde 主轴尺寸	M10 x 1.25LH
<b>Dimensions (L x W x H)</b> Dimensi 体积	1,836x348x236mm (72-1/4"x13-3/4"x9-1/4")
<b>Net Weight</b> Berat Bersih 净重	2.9 - 3.2kg (6.4 - 7.1lbs.)

## DUR189Z

RM 1,127

**Cordless Grass Trimmer**  
Pemotong Rumput Tanpa Kord  
充电式割草机

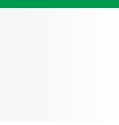

- Comfortable short telescopic pipe provides easy handling in tight spaces

Standard Equipment: Band Assembly, Nylon Cutting Head, Accessory Bag, Hex Wrench

• Z: Without Charger & Battery



<b>Cutting Width</b> Lebar Keratan 切割宽度	Trimmer Head: 300mm (11-3/4") Plastic Blade: 255mm (10")
<b>No Load Speed (RPM)</b> Kelajuan Tanpa Beban 回转数	High: 6,000   Medium: 5,000   Low: 4,000   ADT: 4,000 - 6,000
<b>Spindle Size</b> Saiz Spinde 主轴尺寸	M8 x 1.25RH
<b>Dimensions (L x W x H)</b> Dimensi 体积	1,518-1,618x258x369mm (59-3/4" - 63-3/4"x10-1/8"x14-1/2")
<b>Net Weight</b> Berat Bersih 净重	3.1 - 3.4kg (6.8 - 7.5lbs.)
<b>Continuous Usage Time (approx.)</b> Masa Penggunaan Berterusan 连续使用时间	Low - 181min   Mid - 121min   High - 102min with BL1850B

\* All list price shown are for reference only (exclude SST).

\* Semua harga yang ditunjukkan adalah untuk rujukan sahaja (tidak termasuk SST). 所有显示的建议零售价仅供参考 (不包括SST)。

Cordless Targeted Jobs

LED Flashlight Lampu Saha LED LED照明灯

Vacuum Cleaner Pembersih Vakuum 吸尘器

Drilling / Fastening Gergaji / Pengikat 钻孔 / 紧固

Impact Drilling / Demolition Gergaji / Pemusnah 冲击钻孔 / 拆除

Cutting Pemotong 切割

Grinding / Sanding Pengkilan / Poles 研磨 / 打磨

Sawing Gergaji 锯切

Planing / Routing Pengkilan / Tanggapan 刨削 / 雕刻

Others Lain-lain 其他

Outdoor Power Equipment Alatan Kuat Luar 户外动力设备





Li-ion Ah 6.0 | 5.0 | 4.0 | 3.0 | 2.0 | 1.5

**DUR188LRF** | **DUR188LZ**  
RM 2,282 | RM 1,305

**Cordless Grass Trimmer**  
Pemotong Rumput Tanpa Kord  
充电式割草機

**Split shaft**  
for easily carried & store in car boot

Batang berasingan mudah dimasukkan dalam kereta  
可拆分的把手方便放入车箱



- Plastic triple blade for heavy duty operation

Standard Equipment: Band Assembly, Nylon Cutting Head, Accessory Bag, Hex Wrench

- RFE: 1x Rapid Charger, 2x 3.0Ah Battery
- Z: Without Charger & Battery



<b>Cutting Width</b> Lebar Keratan 切割宽度	Nylon Cutting Head: 300mm (11-3/4") Plastic Blade: 255mm (10")
<b>No Load Speed (RPM)</b> Kelajuan Tanpa Beban 回转速数	High: 6,000   Medium: 5,000   Low: 4,000   ADT: 4,000 - 6,000
<b>Spindle Size</b> Saiz Spindel 主轴尺寸	M8 x 1.25 LH
<b>Dimensions (L x W x H)</b> Dimensi 体积	1,791x258x232mm (70-1/2"x10-1/8"x9-1/8")
<b>Net Weight</b> Berat Bersih 淨重	3.7 - 4.0kg (8.1 - 8.8lbs)
<b>Continuous Usage Time (approx.)</b> Masa Penggunaan Berterusan 连续使用时间	115 min With BL1860B, Plastic Blade (Low Speed) 124 min With BL1860B, Nylon Cutting Head (Low Speed)

**DUR188URFE**  
RM 2,275

**Cordless Grass Trimmer**  
Pemotong Rumput Tanpa Kord  
充电式割草機

**Split shaft**  
for easily carried & store in car boot

Batang berasingan mudah dimasukkan dalam kereta  
可拆分的把手方便放入车箱



- Plastic triple blade for heavy duty operation

Standard Equipment: Band Assembly, Nylon Cutting Head, Accessory Bag, Hex Wrench

- RFE : 1 x Rapid Charger, 2 x 3.0Ah Battery



<b>Cutting Width</b> Lebar Keratan 切割宽度	Nylon Cutting Head: 300mm (11-3/4") Plastic Blade: 255mm (10")
<b>No Load Speed (RPM)</b> Kelajuan Tanpa Beban 回转速数	High: 6,000   Medium: 5,000   Low: 4,000   ADT: 4,000 - 6,000
<b>Spindle Size</b> Saiz Spindel 主轴尺寸	M8 x 1.25 LH
<b>Dimensions (L x W x H)</b> Dimensi 体积	1,791x600x472mm (70-1/2"x23-5/8"x18-5/8")
<b>Net Weight</b> Berat Bersih 淨重	3.5 - 3.8kg (7.7 - 8.3lbs)
<b>Continuous Usage Time (approx.)</b> Masa Penggunaan Berterusan 连续使用时间	115 min With BL1860B, Plastic Blade (Low Speed) 124 min With BL1860B, Nylon Cutting Head (Low Speed)

**DUR187LRF** | **DUR187LZ**  
RM 2,052 | RM 1,075

**Cordless Grass Trimmer**  
Pemotong Rumput Tanpa Kord  
充电式割草機



- 4 Mode rotation selection: 3 stages + ADT mode

Standard Equipment: Band Assembly, Nylon Cutting Head, Accessory Bag, Hex Wrench

- RFE: 1x Rapid Charger, 2x 3.0Ah Battery
- Z: Without Charger & Battery



<b>Cutting Width</b> Lebar Keratan 切割宽度	Nylon Cutting Head: 300mm (11-3/4") Plastic Blade: 255mm (10")
<b>No Load Speed (RPM)</b> Kelajuan Tanpa Beban 回转速数	High: 6,000   Medium: 5,000   Low: 4,000   ADT: 4,000 - 6,000
<b>Spindle Size</b> Saiz Spindel 主轴尺寸	M8 x 1.25 LH
<b>Dimensions (L x W x H)</b> Dimensi 体积	1,791x258x232mm (70-1/2"x10-1/8"x9-1/8")
<b>Net Weight</b> Berat Bersih 淨重	3.4 - 3.7kg (7.5 - 8.2lbs)
<b>Continuous Usage Time (approx.)</b> Masa Penggunaan Berterusan 连续使用时间	Low - 181min   Mid - 121min   High - 102min with BL1850B

**DUR184LZ**  
RM 1,400

**Cordless Grass Trimmer**  
Pemotong Rumput Tanpa Kord  
充电式割草機



- Low noise level for improved user comfort

Standard Equipment: Safety Goggles, Band Assembly, Nylon Cutting Head, Accessory Bag, Hex Wrench

- Z: Without Charger & Battery



<b>Cutting Width</b> Lebar Keratan 切割宽度	Trimmer Head: 300mm (11-3/4")
<b>Spindle Size</b> Saiz Spindel 主轴尺寸	M8 x 1.25RH
<b>Max Output</b> Keluasan Maksima 最大输出	250W
<b>No Load Speed (RPM)</b> Kelajuan Tanpa Beban 回转速数	High: 6,000   Low: 5,000
<b>Dimensions (L x W x H)</b> Dimensi 体积	1,534-1,634x258x417mm (60-1/2" - 64-1/2"x10-1/8"x16-3/8")
<b>Net Weight</b> Berat Bersih 淨重	3.1 - 3.4kg (6.8 - 7.5lbs)
<b>Continuous Usage Time (approx.)</b> Masa Penggunaan Berterusan 连续使用时间	80 min With BL1850B

**DUR182LRF** | **DUR182LZ**  
RM 2,203 | RM 1,548

**Cordless Grass Trimmer**  
Pemotong Rumput Tanpa Kord  
充电式割草機



- BL motor for faster cutting

Standard Equipment: Safety Goggles, Band Assembly, Nylon Cutting Head, Accessory Bag, Hex Wrench

- RF : 1x Rapid Charger, 1x 3.0Ah Battery
- Z : Without Charger & Battery



<b>Cutting Width</b> Lebar Keratan 切割宽度	Trimmer Head: 300mm (11-3/4") Metal Blade: 230mm (9")
<b>No Load Speed (RPM)</b> Kelajuan Tanpa Beban 回转速数	3,500 - 6,000
<b>Spindle Size</b> Saiz Spindel 主轴尺寸	M8 x 1.25 LH
<b>Dimensions (L x W x H)</b> Dimensi 体积	1,843x287x253mm (72-1/2"x11-1/4"x10")
<b>Net Weight</b> Berat Bersih 淨重	3.6kg (8.0lbs)
<b>Continuous Usage Time (approx.)</b> Masa Penggunaan Berterusan 连续使用时间	90 min With BL1830B

\* All list price shown are for reference only (exclude SST).

\* Semua harga yang ditunjukkan adalah untuk rujukan sahaja (tidak termasuk SST). 所有显示的建议零售价仅供参考 (不包括SST)。

Cordless Target Kord 无绳式  
LED Flashlight Lampu Suluh LED LED 照明灯  
Vacuum Cleaner Pembersih Vakuum 吸尘器  
Drilling / Fastening Dremel / Pengikat 钻 / 紧固  
Impact Drilling / Demolition Ganda / Penembak 起工钻 / 拆墙加工  
Cutting Pemotong 切割  
Grinding / Sanding Pengisar / Poles 研磨 / 打磨  
Sawing Gergaji 电锯  
Planing / Routing Pengisar / Tangkai 刨 / 雕刻  
Others Lain-lain 其他  
Outdoor Power Equipment Alatan Kerja Luar 园机-户外



18V

LXT

Li-ion Ah 6.0 5.0 4.0 3.0 2.0 1.5

**DUR181Z**

RM 632

**Cordless String Trimmer**  
Pemotong Rumput Tanpa Kord  
充电式割草机



- Lightweight for reduced operator fatigue

**Standard Equipment:** Safety Goggles, Band Assembly, Nylon Cutting Head, Nylon Cord

- Z: Without Charger & Battery



<b>Cutting Width</b> Lebar Keratan 切割宽度	Trimmer Head: 260mm (10-1/4")
<b>No Load Speed (RPM)</b> Kelajuan Tanpa Beban 回转数	7,800
<b>Dimensions (L x W x H)</b> Dimensi 体积	1,229 - 1,433x267x186 - 257mm (48-1/2 - 56-1/2"x10-1/2"x7-3/8 - 10-1/8")
<b>Net Weight</b> Berat Bersih 净重	2.8 - 3.1kg (6.2 - 6.9lbs.)
<b>Continuous Usage Time (approx.)</b> Masa Penggunaan Berterusan 连续使用时间	75 min with BL1850B

**DUM604Z** 160mm (6-5/16")

RM 632

**Cordless Grass Shear**  
Pemotong Rumput Tanpa Kord  
充电式割草机



- 2 in 1: trimmer and shear blade can be attached

**Standard Equipment:** Grass Receiver, Blade Cover

- Z: Without Charger & Battery



<b>Cutting Width</b> Lebar Keratan 切割宽度	160mm (6-5/16")
<b>Depth Adjustment</b> Pelarasan Kedalaman 深度调整	15mm (9/16")   20mm (13/16")   25mm (1")
<b>Strokes Per Minute (SPM)</b> Kelajuan Strok 冲程速度	2,500
<b>Dimensions (L x W x H)</b> Dimensi 体积	337x177x131mm (13-1/4"x7"x5-1/8")
<b>Net Weight</b> Berat Bersih 净重	1.4 - 1.8kg (3.2 - 4.0 lbs)
<b>Continuous Usage Time (approx.)</b> Masa Penggunaan Berterusan 连续使用时间	200 min with BL1850B

**DUM168Z** 160mm (6-5/16")

RM 638

**Cordless Grass Shear**  
Pemotong Rumput Tanpa Kord  
充电式割草机



- 2 in 1: trimmer and shear blade can be attached

**Standard Equipment:** Base Frame, Blade Cover

- Z: Without Charger & Battery



<b>Cutting Width</b> Lebar Keratan 切割宽度	160mm (6-5/16")
<b>Depth Adjustment</b> Pelarasan Kedalaman 深度调整	10mm (3/8")   20mm (13/16")   30mm (1 - 3/16")
<b>Strokes Per Minute (SPM)</b> Kelajuan Strok 冲程速度	2,500
<b>Dimensions (L x W x H)</b> Dimensi 体积	353x176x130mm (13-7/8"x6-15/16"x5-1/8")
<b>Net Weight</b> Berat Bersih 净重	1.4kg (3.0lbs.)
<b>Continuous Usage Time (approx.)</b> Masa Penggunaan Berterusan 连续使用时间	220 min with BL1850B

**DUC254Z** 250mm (10")

RM 1,698

**Cordless Chain Saw**  
Gergaji Rantai Tanpa Kord  
充电式链锯



- High Cutting Performance, Ultra Lightweight Top Handle Chain Saw

**Standard Equipment:** Saw Chain, Guide Bar, Guide Bar Cover

- Z: Without Charger & Battery



<b>Guide Bar Length</b> Panjang Batang Gergaji 切割长度	250mm (10")
<b>Chain Pitch</b> Kerapatan Rantai 链条齿距	3/8"
<b>Chain Gauge</b> Ketebalan Rantai 链条厚度	1.1mm (0.043")
<b>Chain Speed</b> Kelajuan Rantai 链条速度	0 - 24m/s (0 - 1,440m/min) (0 - 4,720FPM)
<b>Chain Oil Tank Volume</b> Tangki Minyak Pelincir 链油箱	140mL
<b>Dimensions (L x W x H)</b> Dimensi 体积	256x185x190mm (10-1/8"x7-1/2"x7-1/4")
<b>Net Weight</b> Keberatan 净重	2.8 - 3.3kg (6.3 - 7.3lbs)
<b>Work Amount (approx.)</b> Jumlah Kerja 工作量	160 cuts BL1850B (50mm Timber)

**DUC122RME** **DUC122Z** 115mm (4-1/2")

RM 2,670

RM 1,532

**Cordless Chain Saw**  
Gergaji Rantai Tanpa Kord  
充电式链锯



- Low noise & zero emissions for operator comfort

**Standard Equipment:** Saw Chain, Guide Bar, Guide Bar Cover, Chain Oil, File

- RME: 1x Rapid Charger, 2x 4.0Ah Battery
- Z: Without Charger, Battery & Carrying Case



\*Not applicable for Z model



<b>Guide Bar Length</b> Panjang Batang Gergaji 切割长度	115mm (4-1/2")
<b>Chain Pitch</b> Kerapatan Rantai 链条齿距	1/4"
<b>Chain Gauge</b> Ketebalan Rantai 链条厚度	1.3mm (0.05")
<b>Chain Speed</b> Kelajuan Rantai 链条速度	5.0m/s (300m/min) (980FPM)
<b>Chain Oil Tank Volume</b> Tangki Minyak Pelincir 链油箱	80mL (2.7 US oz)
<b>Dimensions (L x W x H)</b> Dimensi 体积	422x195x215mm (16-5/8"x7-5/8"x8-1/2")
<b>Net Weight</b> Keberatan 净重	2.6kg (5.7lbs)
<b>Work Amount (approx.)</b> Jumlah Kerja 工作量	320 cuts BL1850B (50mm Timber)

\* All list price shown are for reference only (exclude SST).

\* Semua harga yang ditunjukkan adalah untuk rujukan sahaja (tidak termasuk SST). 所有显示的建议零售价仅供参考 (不包括SST)。

Cordless  
Target Area TrimmerLED Flashlight  
Lampu Suhu LED  
LED照灯Vacuum Cleaner  
Pembersih Vakuum  
吸尘器Drilling / Fastening  
Gergaji / Pengikat  
钻孔 / 紧固Impact Drilling / Demolition  
Gergaji / Pemusnah  
冲击钻孔 / 拆除施工Cutting  
Pemotong  
切割Grinding / Sanding  
Pengkilan / Pemoles  
研磨 / 砂磨Sawing  
Gergaji  
锯切Planing / Routing  
Pengkilan / Tumpang  
刨削 / 压花Others  
Lain-lain  
其他Outdoor Power Equipment  
Alatan Kerja Luar  
园具 / 户外Makita  
Makita

**18V** **LXT** **Li-ion** Ah 6.0 | 5.0 | 4.0 | 3.0 | 2.0 | 1.5

# Cordless Blower

Mesin Peniup Tanpa Kord 充电式吹风机

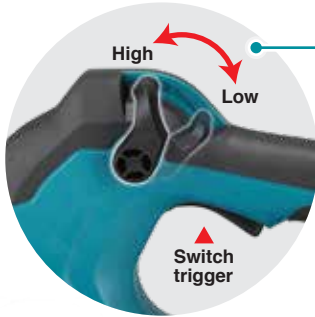

High  
Low  
Switch trigger

**Light weight**  
Ringan 轻量  
**3.0kg**  
with BL1850B  
5.0Ah Battery



**Max Air Velocity**  
Velositi Angin Maksimum  
最大风速  
**52.1 m/s**

**Max Air Volume**  
Isipadu Angin Maksimum  
最大风量  
**13.0 m³/min**

## Hole on the bottom of housing for hanging the machine

Lubang di bahagian bawah casing digunakan untuk menggantung mesin  
机壳底部的孔用于悬挂机器

**DUB184RT** | **DUB184Z**  
RM 2,005 | RM 1,193

**Cordless Blower**  
Mesin Peniup Tanpa Kord  
充电式吹风机



- Compact and lightweight for single handed operation

Standard Equipment: Nozzle, Hex Wrench

- RT: 1x Rapid Charger, 1x 5.0Ah Battery
- Z: Without Charger & Battery



<b>Max Air Volume</b> Isipadu Angin Maksimum 最大风量	13.0m³/min (459CFM)
<b>Max Air Velocity</b> Velositi Angin Maksimum 最大风速	52.1m/s (116MPH)
<b>No Load Speed (RPM)</b> Kelajuan Tanpa Beban 回转数	0 - 18,000
<b>Dimensions (L x W x H)</b> Dimensi 体积	825x160x285mm (32-1/2"x6-5/16"x11-1/4")
<b>Net Weight</b> Berat Bersih 净重	2.5 - 3.0kg (5.4 - 6.7lbs.)

**DUB183Z**  
RM 500

**Cordless Blower**  
Mesin Peniup Tanpa Kord  
充电式吹风机



- Long blowing nozzle with curved tip for optimal blowing performance

Standard Equipment: Garden Nozzle

- Z: Without Charger & Battery



<b>Air Volume</b> Isipadu Angin 风量	2.6m³/min
<b>Air Speed</b> Kelajuan Angin 风速	52m/s
<b>No Load Speed (RPM)</b> Kelajuan Tanpa Beban 回转数	0-18,000
<b>Dimensions (L x W x H)</b> Dimensi 体积	845x155x212mm (33-1/4"x6-1/8"x8-3/8")
<b>Net Weight</b> Berat Bersih 净重	1.7kg (3.8lbs)
<b>Continuous Usage Time (approx.)</b> Masa Penggunaan Berterusan 连续使用时间	Low - 129 min   Mid - 43 min   High - 18 min with BL1850B

**DUB182Z**  
RM 382

**Cordless Blower**  
Mesin Peniup Tanpa Kord  
充电式吹风机



- Compact and ergonomic design at only 525mm (20-3/4") long

Standard Equipment: Nozzle assembly

- Z: Without Charger & Battery



<b>Air Volume</b> Isipadu Angin 风量	2.6m³/min
<b>Air Speed</b> Kelajuan Angin 风速	80m/s
<b>Air Pressure</b> Udara Tekanan 气压	5.4kPa (550mmH <sub>2</sub> O)
<b>No Load Speed (RPM)</b> Kelajuan Tanpa Beban 回转数	0-18,000
<b>Dimensions (L x W x H)</b> Dimensi 体积	525x155x212mm (20-3/4"x6-1/8"x8-3/8")
<b>Net Weight</b> Berat Bersih 净重	1.7kg (3.7lbs)
<b>Continuous Usage Time (approx.)</b> Masa Penggunaan Berterusan 连续使用时间	20 min with BL1850B

\* All list price shown are for reference only (exclude SST).

\* Semua harga yang ditunjukkan adalah untuk rujukan sahaja (tidak termasuk SST). 所有显示的建议零售价仅供参考 (不包括SST)。

Cordless Target Kord 无绳式  
LED Flashlight Lampu Suluh LED LED照明灯  
Vacuum Cleaner Pemilauhi VAKUUM 吸尘器  
Drilling / Fastening Dremel / Pengikat 钻头 / 螺丝  
Impact Drilling / Demolition Gergaji / Pemecah 石工钻头 / 电锤加工  
Cutting Pemotong 切割机  
Grinding / Sanding Pengisar / Pucuk 磨削 / 砂磨  
Sawing Gergaji 电锯  
Planing / Routing Pengisar / Tangkapan 刨削 / 雕刻  
Others Lain-lain 其他  
Outdoor Power Equipment Alatan Kerja Luar 园具-户外





Li-ion Ah 6.0 5.0 4.0 3.0 2.0 1.5

**DCU180Z**

RM 5,740

**Battery Powered Wheelbarrow**

Kereta Sorong Berkuasa Bateri  
充电式搬运车



- Ideal for use at urban construction sites and on farms



VIDEO CLIP  
Models and specs may vary by country



Standard Equipment:  
Lock Key, Support Legs, Wrenches

- Z: Without Charger & Battery



<b>Max Load Capacity</b> Kapasiti Berat Maksimum 最重载量	130kg (290lbs.)
<b>Traveling Speed</b> Kelajuan Perjalanan 行驶速度	Forward High: 0 - 3.5km/h   Forward Low: 0 - 1.5km/h   Reverse: 0 - 1 km/h
<b>Max Climbing Capacity</b> Pergerakan atas Kecerunan Maksimum 最大爬坡能力	12°
<b>Dimensions (L x W x H)</b> Dimensi 体积	When carrier is installed/ During operation: 1,315x1,060x900mm (51-3/4"x41-3/4"x35-1/2") When carrier is installed/ When stored: 1,110x820x820mm (43-3/4"x32-1/4"x32-1/4") When bucket is installed/ During operation: 1,310x820x900 mm (51-1/2"x32-1/4"x35-1/2") When bucket is installed/ When stored: 1,110x820x820mm (43-3/4"x32-1/4"x32-1/4")
<b>Net Weight</b> Keberatan 净重	39.3 - 44.8kg (86.5 - 98.7lbs)
<b>Continuous Usage Time (approx.)</b> Masa Penggunaan Berterusan 连续使用时间	100 min with BL1850B x2

**DVF154Z 15L**

RM 3,008

**Cordless Garden Sprayer**  
Penyembur Tanaman Tanpa Kord  
充电式花园喷雾器



- Reduced running cost with Li-ion battery



Standard Equipment: Upright Double-Headed Nozzle, Wide-Angle Herbicide Nozzle, Spray Pipe Holder, Shoulder Harness

- Z: Without Charger & Battery

<b>Max Pressure</b> Tekanan Maksimum 最大水压	0.3MPa (3 kgf/cm <sup>2</sup> )
<b>Chemical Tank</b> Tangki Kimia 化学箱容量	15L
<b>Dimensions (L x W x H)</b> Dimensi 体积	345x235x525mm (13-5/8"x9-1/4"x20-3/4")
<b>Net Weight</b> Berat Bersih 净重	4.1 - 4.4kg (9.1 - 9.7lbs)
<b>Continuous Usage Time (approx.)</b> Masa Penggunaan Berterusan 连续使用时间	Wide Angle Nozzle 344 min Double Nozzle 215 min with BL1850B

**DVR450Z 1,200mm (4.0ft)**

RM 1,538

**Cordless Concrete Vibrator**  
Penggetar Konkrit Tanpa Kord  
充电式混凝土振动器



- Makita-built motor delivers 13,000VPM to help increase strength of concrete



- Z: Without Charger & Battery

<b>Diameter of Vibrator</b> Diameter Penggetar 振动器的直径	25mm (1")
<b>Flexible Shaft Assembly Length</b> Kelajuan Pemasangan Fleksibel 柔性轴组件长度	1,200mm (4.0 ft)
<b>Vibrations Per Minute (VPM)</b> Getaran Setiap Minit 每分钟振动	13,000
<b>Dimensions (L x W x H)</b> Dimensi 体积	1,483x93x250mm (58-1/2"x3-5/8"x9-7/8")
<b>Net Weight</b> Berat Bersih 净重	3.3 - 3.8kg (7.3 - 8.3lbs)
<b>Continuous Usage Time (approx.)</b> Masa Penggunaan Berterusan 连续使用时间	41 min with BL1850B

**DCG180RFE**

RM 2,347

**DCG180RFEB**

RM 2,398

**DCG180ZB**

RM 1,423

**DCG180Z**

RM 1,372

**Cordless Caulking Gun**  
Pistol Caulking Tanpa Kord  
充电式填缝枪



- 5 Speed dial optimizes flow rate 0 - 28mm/sec

Standard Equipment:  
RFE / Z: 300mL Holder A, Holder Joint A, Piston, Rack 42, Safety Goggles  
RFEB / ZB: 600mL Holder B, Holder Joint B, Piston, Nozzle, Rubber Ring, Rack 64, Safety Goggles

- RFE: 1x Rapid Charger, 2x 3.0Ah Battery
- RFEB: 1x Rapid Charger, 2x 3.0Ah Battery
- ZB: Without Charger, Battery & Carrying Case
- Z: Without Charger, Battery & Carrying Case



VIDEO CLIP  
Models and specs may vary by country

<b>Max Dispersing Force</b> Tujahan Maksimum 最大推力	5,000N (1,100lbs)
<b>No Load Speed</b> Kelajuan Tanpa Beban 回转数	0 - 28mm/sec. (0 - 66in/min.)
<b>Holder Size</b> Kapasiti 容量	300mL   600mL (Optional Accessories 800mL Holder)
<b>Dimensions (L x W x H)</b> Dimensi 体积	404x108x281mm (15-7/8"x4-1/4"x11-1/8")
<b>Net Weight</b> Berat Bersih 净重	2.1 - 3.0kg (4.7 - 6.6lbs)
<b>Work Amount (approx.)</b> Jumlah Kerja 工作量	500 pcs with BL1830B 300ml silicon sealant

**DMP180Z**

RM 585

**Cordless Inflator**  
Inflator Tanpa Kord  
充电式打气机



- Inflates the Tires of Cars, Bikes, Sport Balls, etc

Standard Equipment: British Adapter, French Adapter, Ball Adapter, Swim Ring Adapter

- Z: Without Charger & Battery



<b>Max Air Pressure</b> Udara Tekanan Maksimum 最大气压	830kPa (121 PSI) [8.3 bar]
<b>Air Discharge Amount</b> Pelepasan Udara 空气排放量	200kPa: 12L/min   700kPa: 8L/min   830kPa: 7L/min
<b>Hose Length</b> Panjang Hos 软管长度	65cm (25-1/2")
<b>Dimensions (L x W x H)</b> Dimensi 体积	246x80x174mm (9-11/16"x3-1/8"x6-7/8")
<b>Net Weight</b> Berat Bersih 净重	1.4 - 1.7kg (3.1 - 3.8lbs.)
<b>Work Amount (approx.)</b> Jumlah Kerja 工作量	9 tires with BL1850B (16" Car Tires 215/60R16)

\* All list price shown are for reference only (exclude SST).

\* Semua harga yang ditunjukkan adalah untuk rujukan sahaja (tidak termasuk SST). 所有显示的建议零售价仅供参考 (不包括SST)。

Cordless  
Targeted Jobs

LED Flashlight  
Lampu Suhu LED  
LED照明灯

Vacuum Cleaner  
Pembersih Vakuum  
吸尘器

Drilling / Fastening  
Ganjal / Pasang  
钻孔 / 紧固

Impact Drilling / Demolition  
Ganjal / Pasang  
冲击钻孔 / 拆除施工

Cutting  
Pemotong  
切割

Grinding / Sanding  
Pengisar / Pasah  
研磨 / 砂磨

Sawing  
Gergaji  
锯切

Planing / Routing  
Pengisar / Tanggung  
刨削 / 雕刻

Others  
Lain-lain  
其他

Outdoor Power Equipment  
Alatan Kuat Luar  
户外动力设备



12V<sub>max</sub>

CXT

Li-ion Ah 4.0 2.0 1.5

Cordless  
Tanpa Kord / 无线

LED Flashlight  
Lampu Suluh LED  
LED 照明灯

Vacuum Cleaner  
Penyedut Vakuum  
吸尘器

Drilling / Fastening  
Dandi / Pengekat  
钻孔 / 紧固

Impact Drilling / Demolition  
Garuhi / Penumbuh  
起工钻孔 / 拆墙加工

Cutting  
Pemotong  
切割

Grinding / Sanding  
Pengisar / Piskin  
磨削 / 打磨

Sawing  
Gergaji  
电锯

Planing / Routing  
Pengaram / Tangkai  
刨削 / 雕刻

Others  
Lain-lain  
其他

Outdoor Power Equipment  
Alatan Kerja Luar  
园具-户外

Makita  
マキタ

**DF332DSME** RM 1,510 | **DF332DSAE** RM 1,328 | **DF332DZ** 10mm (3/8") RM 680

**Cordless Driver Drill**  
Gerudi Pemutar Skru Tanpa Kord  
充电式螺丝起子电钻



- BL motor with high power

Standard Equipment: Phillips Bit, Belt Clip

- SME: 1x Speed Charger, 2x 4.0Ah Battery
- SAE: 1x Speed Charger, 2x 2.0Ah Battery
- Z: Without Charger, Battery & Carrying Case



<b>Capacity</b> Kapasiti 能力	Steel: 10 (3/8") Wood: 28mm (1-1/8")
<b>Chuck Capacity</b> Kapasiti Chuck 夹头能力	0.8 - 10mm (1/32 - 3/8")
<b>No Load Speed (RPM)</b> Kelajuan Tanpa Beban 回转数	High: 0 - 1,500   Low: 0 - 450
<b>Max Fastening Torque</b> Maksimum Tenaga Pemutaran Pengancing 最快扭力	Hard: 35N-m (310in.lbs.) Soft: 21N-m (190in.lbs.)
<b>Max Lock Torque</b> Pemutaran Tenaga Maksimum 最大扭力	32N-m (280in.lbs.)
<b>Dimensions (L x W x H)</b> Dimensi 体积	154x66x217mm (6-1/16"x2-5/8"x8-1/2")
<b>Net Weight</b> Berat Bersih 净重	1.0 - 1.2kg (2.3 - 2.6lbs)
<b>Work Amount (approx.)</b> Jumlah Kerja 工作量	460 holes with BL1021B Drilling ø9mm Auger Bit, Melapi 30mm Thickness

**DF333DSME** RM 1,160 | **DF333DWA** RM 895 | **DF333DZ** 10mm (3/8") RM 330

**Cordless Driver Drill**  
Gerudi Pemutar Skru Tanpa Kord  
充电式螺丝起子电钻



- Increased motor power for higher speed and max tightening torque

Standard Equipment: Phillips Bit, Belt Clip

- SME: 1x Speed Charger, 2x 4.0Ah Battery
- WAE: 1x Standard Charger, 2x 2.0Ah Battery
- Z: Without Charger, Battery & Carrying Case



<b>Capacity</b> Kapasiti 能力	Steel: 10mm (3/8") Wood: 21mm (13/16")
<b>Chuck Capacity</b> Kapasiti Chuck 夹头能力	0.8 - 10mm (1/32 - 3/8")
<b>No Load Speed (RPM)</b> Kelajuan Tanpa Beban 回转数	High: 0 - 1,700   Low: 0 - 450
<b>Max Fastening Torque</b> Maksimum Tenaga Pemutaran Pengancing 最快扭力	Hard: 30N-m (270in.lbs.) Soft: 14N-m (130in.lbs.)
<b>Max Lock Torque</b> Pemutaran Tenaga Maksimum 最大扭力	28N-m (250in.lbs.)
<b>Dimensions (L x W x H)</b> Dimensi 体积	179x66x212mm (7"x2-5/8"x8-3/8")
<b>Net Weight</b> Berat Bersih 净重	1.1 - 1.2kg (2.4 - 2.7lbs.)

**DF331DSME** RM 1,160 | **DF331DZ** 10mm (3/8") RM 330

**Cordless Driver Drill**  
Gerudi Pemutar Skru Tanpa Kord  
充电式螺丝起子电钻



- Increased motor power for higher speed

Standard Equipment: Phillips Bit, Belt Clip

- SME: 1x Speed Charger, 2x 4.0Ah Battery
- Z: Without Charger, Battery & Carrying Case



<b>Capacity</b> Kapasiti 能力	Steel: 10mm (3/8") Wood: 21mm (13/16")
<b>Chuck Capacity</b> Kapasiti Chuck 夹头能力	0.8 - 10mm (1/32 - 3/8")
<b>No Load Speed (RPM)</b> Kelajuan Tanpa Beban 回转数	High: 0 - 1,700   Low: 0 - 450
<b>Max Fastening Torque</b> Maksimum Tenaga Pemutaran Pengancing 最快扭力	Hard: 30N-m (270in.lbs.) Soft: 14N-m (130in.lbs.)
<b>Max Lock Torque</b> Pemutaran Tenaga Maksimum 最大扭力	28N-m (250in.lbs.)
<b>Dimensions (L x W x H)</b> Dimensi 体积	189x66x209mm (7-7/16"x2-5/8"x8-1/4")
<b>Net Weight</b> Berat Bersih 净重	1.1 - 1.3kg (2.4 - 2.8lbs)
<b>Work Amount (approx.)</b> Jumlah Kerja 工作量	350 holes with BL1021B Drilling ø9mm Auger Bit, Melapi 30mm Thickness

**DF032DSME** RM 1,488 | **DF032DSAE** RM 1,305 | **DF032DZ** 10mm (3/8") RM 658

**Cordless Driver Drill**  
Gerudi Pemutar Skru Tanpa Kord  
充电式螺丝起子电钻



- BL motor with high power

Standard Equipment: Phillips Bit, Belt Clip

- SME: 1x Speed Charger, 2x 4.0Ah Battery
- SAE: 1x Speed Charger, 2x 2.0Ah Battery
- Z: Without Charger, Battery & Carrying Case



<b>Capacity</b> Kapasiti 能力	Steel: 10mm (3/8") Wood: 28mm (1-1/8")
<b>Chuck Capacity</b> Kapasiti Chuck 夹头能力	6.35mm (1/4")
<b>No Load Speed (RPM)</b> Kelajuan Tanpa Beban 回转数	High: 0 - 1,500   Low: 0 - 450
<b>Max Fastening Torque</b> Maksimum Tenaga Pemutaran Pengancing 最快扭力	Hard: 35N-m (310in.lbs.) Soft: 21N-m (190in.lbs.)
<b>Max Lock Torque</b> Pemutaran Tenaga Maksimum 最大扭力	32N-m (280in.lbs.)
<b>Dimensions (L x W x H)</b> Dimensi 体积	124x66x217mm (4-7/8"x2-5/8"x8-1/2")
<b>Net Weight</b> Berat Bersih 净重	0.88 - 1kg (1.9 - 2.3lbs)
<b>Work Amount (approx.)</b> Jumlah Kerja 工作量	200 holes with BL1021B Wood Drilling ø3x1.6mm

**DF033DSME** RM 1,127 | **DF033DWA** RM 862 | **DF033DZ** 10mm (3/8") RM 298

**Cordless Driver Drill**  
Gerudi Pemutar Skru Tanpa Kord  
充电式螺丝起子电钻



- Increased motor power for higher speed and max tightening torque

Standard Equipment: Phillips Bit, Belt Clip

- SME: 1x Speed Charger, 2x 4.0Ah Battery
- WAE: 1x Standard Charger, 2x 2.0Ah Battery
- Z: Without Charger, Battery & Carrying Case



<b>Capacity</b> Kapasiti 能力	Steel: 10mm (3/8") Wood: 21mm (13/16")
<b>Chuck Capacity</b> Kapasiti Chuck 夹头能力	6.35mm (1/4")
<b>No Load Speed (RPM)</b> Kelajuan Tanpa Beban 回转数	High: 0 - 1,700   Low: 0 - 450
<b>Max Fastening Torque</b> Maksimum Tenaga Pemutaran Pengancing 最快扭力	Hard: 30N-m (270in.lbs.) Soft: 14N-m (130in.lbs.)
<b>Max Lock Torque</b> Pemutaran Tenaga Maksimum 最大扭力	28N-m (250in.lbs.)
<b>Dimensions (L x W x H)</b> Dimensi 体积	149x66x212mm (5-7/8"x2-5/8"x8-3/8")
<b>Net Weight</b> Berat Bersih 净重	0.9 - 1.1kg (2.1 - 2.4lbs.)

\* All list price shown are for reference only (exclude SST).

\* Semua harga yang ditunjukkan adalah untuk rujukan sahaja (tidak termasuk SST). 所有显示的建议零售价仅供参考 (不包括SST)。



12V<sub>max</sub>

CXT

Li-ion Ah 4.0 2.0 1.5

**DF031DSME** RM 1,127 | **DF031DWAE** RM 862 | **DF031DWYE** RM 807 | **DF031DZ** 10mm (3/8") RM 298

**Cordless Driver Drill**  
Gerudi Pemutar Skru Tanpa Kord  
充电式螺丝起子电钻



• Ideal for work in tight spaces

Standard Equipment: Phillips Bit, Belt Clip

- SME: 1x Speed Charger, 2x 4.0Ah Battery
- WAE: 1x Standard Charger, 2x 2.0Ah Battery
- WYE: 1x Standard Charger, 2x 1.5Ah Battery
- Z: Without Charger, Battery & Carrying Case



<b>Capacity</b> Kapasiti 能力	Steel: 10mm (3/8") Wood: 21mm (13/16") 6.35mm (1/4")
<b>Hex Shank</b> Batang Heksagon 六角柄	
<b>No Load Speed (RPM)</b> Kelajuan Tanpa Beban 回转数	High: 0 - 1,700   Low: 0 - 450
<b>Max Fastening Torque</b> Maksimum Tenaga Pemutaran Pengancing 最快扭力	Hard: 30N-m (270in.lbs.) Soft: 14N-m (130in.lbs.)
<b>Max Lock Torque</b> Pemutaran Tenaga Maksimum 最大扭矩	28N-m (250in.lbs.)
<b>Dimensions (L x W x H)</b> Dimensi 体积	157x66x209mm (6-3/16"x2-5/8"x8-1/4")
<b>Net Weight</b> Berat Bersih 净重	0.94 - 1.1kg (2.1 - 2.5lbs)
<b>Work Amount (approx.)</b> Jumlah Kerja 工作量	160 holes with BL1021B Wood Drilling ø3x1.6mm

**HP332DSME** RM 1,577 | **HP332DSAE** RM 1,395 | **HP332DZ** 10mm (3/8") RM 748

**Cordless Hammer Driver Drill**  
Tukul Pemutar Skru Bergerudi Tanpa Kord  
充电式冲击螺丝起子电钻



• Fast hammer drilling in masonry materials

Standard Equipment: Phillips Bit, Belt Clip

- SME: 1x Speed Charger, 2x 4.0Ah Battery
- SAE: 1x Speed Charger, 2x 2.0Ah Battery
- Z: Without Charger, Battery & Carrying Case



<b>Capacity</b> Kapasiti 能力	Steel: 10mm (3/8") Wood: 28mm (1-1/8") Masonry: 8mm (5/16")
<b>Chuck capacity</b> Kapasiti Chuck 夹头能力	0.8 - 10mm (1/32 - 3/8")
<b>Impacts Per Minute (IPM)</b> Impak Per Minit 冲击数	High: 0 - 22,500   Low: 0 - 6,750
<b>No Load Speed (RPM)</b> Kelajuan Tanpa Beban 回转数	High: 0 - 1,500   Low: 0 - 450
<b>Max Fastening Torque</b> Maksimum Tenaga Pemutaran Pengancing 最快扭力	Hard: 35N-m (310in.lbs.) Soft: 21N-m (190in.lbs.)
<b>Max Lock Torque</b> Pemutaran Tenaga Maksimum 最大扭矩	32N-m (280in.lbs.)
<b>Dimensions (L x W x H)</b> Dimensi 体积	168x66x217mm (6-5/8"x2-5/8"x8-1/2")
<b>Net Weight</b> Berat Bersih 净重	1.1 - 1.3kg (2.4 - 2.8lbs)
<b>Work Amount (approx.)</b> Jumlah Kerja 工作量	460 holes with BL1021B Drilling ø9mm Auger Bit, Melapi 30mm Thickness

**HP333DSME** RM 1,235 | **HP333DWAE** RM 972 | **HP333DZ** 10mm (3/8") RM 407

**Cordless Hammer Driver Drill**  
Tukul Pemutar Skru Bergerudi Tanpa Kord  
充电式冲击螺丝起子电钻



• Increased motor power for higher speed and max tightening torque

Standard Equipment: Phillips Bit, Belt Clip

- SME: 1x Speed Charger, 2x 4.0Ah Battery
- WAE: 1x Standard Charger, 2x 2.0Ah Battery
- Z: Without Charger, Battery & Carrying Case



<b>Capacity</b> Kapasiti 能力	Steel: 10mm (3/8") Wood: 21mm (13/16") Masonry: 8mm (5/16")
<b>Chuck Capacity</b> Kapasiti Chuck 夹头能力	0.8 - 10mm (1/32 - 3/8")
<b>Impacts Per Minute (IPM)</b> Impak Per Minit 冲击数	High: 0 - 25,500   Low: 0 - 6,750
<b>No Load Speed (RPM)</b> Kelajuan Tanpa Beban 回转数	High: 0 - 1,700   Low: 0 - 450
<b>Max Fastening Torque</b> Maksimum Tenaga Pemutaran Pengancing 最快扭力	Hard: 30N-m (270in.lbs.) Soft: 14N-m (130in.lbs.)
<b>Max Lock Torque</b> Pemutaran Tenaga Maksimum 最大扭矩	28N-m (250 in.lbs.)
<b>Dimensions (L x W x H)</b> Dimensi 体积	193x66x212mm (7-5/8"x2-5/8"x8-3/8")
<b>Net Weight</b> Berat Bersih 净重	1.1 - 1.3kg (2.4 - 2.9lbs.)

**HP331DSME** RM 1,235 | **HP331DWAE** RM 972 | **HP331DWYE** 10mm (3/8") RM 917

**Cordless Hammer Driver Drill**  
Tukul Pemutar Skru Bergerudi Tanpa Kord  
充电式冲击螺丝起子电钻



• High speed mode for speedy drilling

Standard Equipment: Phillips Bit, Belt Clip

- SME: 1x Speed Charger, 2x 4.0Ah Battery
- WAE: 1x Standard Charger, 2x 2.0Ah Battery
- WYE: 1x Standard Charger, 2x 1.5Ah Battery



<b>Capacity</b> Kapasiti 能力	Steel: 10mm (3/8") Wood: 21mm (13/16") Masonry: 8mm (5/16")
<b>Impacts Per Minute (IPM)</b> Impak Per Minit 冲击数	High: 0 - 25,500   Low: 0 - 6,750
<b>No Load Speed (RPM)</b> Kelajuan Tanpa Beban 回转数	High: 0 - 1,700   Low: 0 - 450
<b>Max Fastening Torque</b> Maksimum Tenaga Pemutaran Pengancing 最快扭力	Hard: 30N-m (270in.lbs.) Soft: 14N-m (130in.lbs.)
<b>Max Lock Torque</b> Pemutaran Tenaga Maksimum 最大扭矩	28N-m (250in.lbs.)
<b>Dimensions (L x W x H)</b> Dimensi 体积	201x66x209mm (7-7/8"x2-5/8"x8-1/4")
<b>Net Weight</b> Berat Bersih 净重	1.1 - 1.3kg (2.5 - 2.9lbs)
<b>Work Amount (approx.)</b> Jumlah Kerja 工作量	350 holes with BL1021B Drilling ø9mm Auger Bit, Melapi 30mm Thickness

**TD111DSME** RM 1,510 | **TD111DWAE** RM 1,245 | **TD111DWYE** RM 1,190 | **TD111DZ** RM 680

**Cordless Impact Driver**  
Pemutar Skru Impak Tanpa Kord  
充电式冲击螺丝起子机

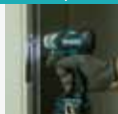

• 3-Mode operation: A-mode/ Hard mode/ Soft mode

Standard Equipment: Phillips Bit, Belt Clip

- SME: 1x Speed Charger, 2x 4.0Ah Battery
- WAE: 1x Standard Charger, 2x 2.0Ah Battery
- WYE: 1x Standard Charger, 2x 1.5Ah Battery
- Z: Without Charger, Battery & Carrying Case



<b>Capacity</b> Kapasiti 能力	Machine Screw: M4 - M8mm (5/32" - 5/16") Standard Bolt: M5 - M14 (3/16" - 9/16") High Tensile Bolt: M5 - M12 (3/16" - 1/2") Coarse thread (in length): 22 - 90mm (7/8" - 3-1/2")
<b>Hex Shank</b> Batang Heksagon 六角柄	6.35mm (1/4")
<b>No Load Speed (RPM)</b> Kelajuan Tanpa Beban 回转数	Hard: 0 - 3,000   Soft: 0 - 1,300
<b>Impacts Per Minute (IPM)</b> Impak Per Minit 冲击数	Hard: 0 - 3,900   Soft: 0 - 1,600
<b>Max Fastening Torque</b> Maksimum Tenaga Pemutaran Pengancing 最快扭力	135N-m (1,200in.lbs.)
<b>Dimensions (L x W x H)</b> Dimensi 体积	135x66x210mm (5-5/16"x2-5/8"x8-1/4")
<b>Net Weight</b> Berat Bersih 净重	0.97 - 1.1kg (2.1 - 2.5lbs)
<b>Work Amount (approx.)</b> Jumlah Kerja 工作量	340 pcs with BL1021B Coarse Thread Wood Screw 45mm (Melapi)

\* All list price shown are for reference only (exclude SST).

\* Semua harga yang ditunjukkan adalah untuk rujukan sahaja (tidak termasuk SST). 所有显示的建议零售价仅供参考 (不包括SST)。

Cordless  
Target Applications

LED Flashlight  
Lampu Saku LED  
LED手电筒

Vacuum Cleaner  
Pembersih Vakuum  
吸尘器

Drilling / Fastening  
Gerudi / Pengancing  
钻孔 / 紧固

Impact Drilling / Demolition  
Gerudi / Pembongkaran  
冲击钻孔 / 拆除施工

Cutting / Sanding  
Pengiraian / Pemolesan  
切割 / 打磨

Sanding / Grinding  
Pemolesan / Pengiraian  
打磨 / 切割

Planing / Routing  
Pengiraian / Tumpang  
刨削 / 压边

Others  
Lain-lain  
其他

Outdoor Power Equipment  
Alatan Kuasa Luar  
园机 / 户外

Makita  
工具



<b>TD110DSME</b> RM 1,160	<b>TD110DWAE</b> RM 895	<b>TD110DWYE</b> RM 840	<b>TD110DZ</b> RM 330
------------------------------	----------------------------	----------------------------	--------------------------

**Cordless Impact Driver**

Pemutar Skru Impak Tanpa Kord  
充电式冲击螺丝起子机



- Compact and Lightweight

Standard Equipment: Phillips Bit, Belt Clip

- SME: 1x Speed Charger, 2x 4.0Ah Battery
- WAE: 1x Standard Charger, 2x 2.0Ah Battery
- WYE: 1x Standard Charger, 2x 1.5Ah Battery
- Z: Without Charger, Battery & Carrying Case



<b>Capacity</b> Kapasiti 能力	Machine Screw: M4 - M8mm (5/32" - 5/16") Standard Bolt: M5 - M12 (3/16" - 1/2") High Tensile Bolt: M5 - M10 (3/16" - 3/8") Coarse thread (in length): 22 - 90mm (7/8" - 3-1/2") 6.35mm (1/4")
<b>Hex Shank</b> Batang Heksagon 六角柄	
<b>No Load Speed (RPM)</b> Kelajuan Tanpa Beban 回转速数	0 - 2,600
<b>Impacts Per Minute (IPM)</b> Impak Per Minit 冲击数	0 - 3,500
<b>Max Fastening Torque</b> Maksimum Tenaga Pemutaran Pengancing 最快扭力	110N-m (970in.lbs.)
<b>Dimensions (L x W x H)</b> Dimensi 体积	153x66x204mm (6"x2-5/8"x8-1/8")
<b>Net Weight</b> Berat Bersih 淨重	1.0 - 1.2kg (2.3 - 2.6lbs)
<b>Work Amount (approx.)</b> Jumlah Kerja 工作量	250 pcs with BL1021B Coarse Thread Wood Screw 45mm (Melapi)

<b>TW161DSME</b> RM 1,422	<b>TW161DWAE</b> RM 1,157	<b>TW161DZ</b> 12.7mm (1/2") RM 593
------------------------------	------------------------------	--

**Cordless Impact Wrench**

Perengkuh Impak Tanpa Kord  
充电式冲击套筒扳手



- Reverse Rotation Auto-Stop Mode stops in 0.2 seconds after loosened enough

Standard Equipment: Belt Clip

- SME: 1x Speed Charger, 2x 4.0Ah Battery
- WAE: 1x Standard Charger, 2x 2.0Ah Battery
- Z: Without Charger, Battery & Carrying Case



<b>Fastening Capacities</b> Kapasiti 能力	Standard Bolt: M8 - M16 (5/16" - 5/8") High Tensile Bolt: M6 - M12 (1/4" - 1/2") 12.7mm (1/2")
<b>Square Drive</b> Batang Segi Empat 四方头	
<b>No Load Speed (RPM)</b> Kelajuan Tanpa Beban 回转速数	Hard: 0 - 2,400   Soft: 0 - 1,300
<b>Impacts Per Minute (IPM)</b> Impak Per Minit 冲击数	Hard: 0 - 3,600   Soft: 0 - 2,000
<b>Max Fastening Torque</b> Maksimum Tenaga Pemutaran Pengancing 最快扭力	165N-m (122ft.lbs.)
<b>Dimensions (L x W x H)</b> Dimensi 体积	150x66x213mm (5-7/8"x2-5/8"x8-3/8")
<b>Net Weight</b> Berat Bersih 淨重	1.1 - 1.2kg (2.4 - 2.7lbs.)

<b>TW160DZ</b> 9.5mm (3/8") RM 593
---------------------------------------

**Cordless Impact Wrench**

Perengkuh Impak Tanpa Kord  
充电式冲击套筒扳手



- 9.5mm (3/8") square drive fits most common automotive sockets

Standard Equipment: Belt Clip

- Z: Without Charger & Battery

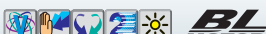

<b>Fastening Capacities</b> Kapasiti 能力	Standard Bolt: M8 - M16 (5/16" - 5/8") High Tensile Bolt: M6 - M12 (1/4" - 1/2") 9.5mm (3/8")
<b>Square Drive</b> Batang Segi Empat 四方头	
<b>No Load Speed (RPM)</b> Kelajuan Tanpa Beban 回转速数	Hard: 0 - 2,400   Soft: 0 - 1,300
<b>Impacts Per Minute (IPM)</b> Impak Per Minit 冲击数	Hard: 0 - 3,600   Soft: 0 - 2,000
<b>Max Fastening Torque</b> Maksimum Tenaga Pemutaran Pengancing 最快扭力	160N-m (120ft.lbs.)
<b>Dimensions (L x W x H)</b> Dimensi 体积	144x66x213mm (5-5/8"x2-5/8"x8-3/8")
<b>Net Weight</b> Berat Bersih 淨重	1.0 - 1.2kg (2.2 - 2.6lbs.)

<b>TW141DSME</b> RM 1,202	<b>TW141DWAE</b> RM 937	<b>TW141DZ</b> 12.7mm (1/2") RM 372
------------------------------	----------------------------	--

**Cordless Impact Wrench**

Perengkuh Impak Tanpa Kord  
充电式冲击套筒扳手



- Ultra compact design and lightweight

Standard Equipment: Belt Clip

- SME: 1x Speed Charger, 2x 4.0Ah Battery
- WAE: 1x Standard Charger, 2x 2.0Ah Battery
- Z: Without Charger, Battery & Carrying Case



<b>Fastening Capacities</b> Kapasiti 能力	Standard Bolt: M8 - M16 (5/16" - 5/8") High Tensile Bolt: M6 - M12 (1/4" - 1/2") 12.7mm (1/2")
<b>Square Drive</b> Batang Segi Empat 四方头	
<b>No Load Speed (RPM)</b> Kelajuan Tanpa Beban 回转速数	0 - 2,600
<b>Impacts Per Minute (IPM)</b> Impak Per Minit 冲击数	0 - 3,200
<b>Max Fastening Torque</b> Maksimum Tenaga Pemutaran Pengancing 最快扭力	145N-m (107ft.lbs.)
<b>Dimensions (L x W x H)</b> Dimensi 体积	168x66x205mm (6-5/8"x2-5/8"x8-1/8")
<b>Net Weight</b> Berat Bersih 淨重	1.1 - 1.2kg (2.4 - 2.7lbs.)

<b>TW140DZ</b> 9.5mm (3/8") RM 372
---------------------------------------

**Cordless Impact Wrench**

Perengkuh Impak Tanpa Kord  
充电式冲击套筒扳手



- 9.5mm (3/8") square drive fits most common automotive sockets

Standard Equipment: Belt Clip

- Z: Without Charger & Battery



<b>Fastening Capacities</b> Kapasiti 能力	Standard Bolt: M8 - M16 (5/16" - 5/8") High Tensile Bolt: M6 - M12 (1/4" - 1/2") 9.5mm (3/8")
<b>Square Drive</b> Batang Segi Empat 四方头	
<b>No Load Speed (RPM)</b> Kelajuan Tanpa Beban 回转速数	0 - 2,600
<b>Impacts Per Minute (IPM)</b> Impak Per Minit 冲击数	0 - 3,200
<b>Max Fastening Torque</b> Maksimum Tenaga Pemutaran Pengancing 最快扭力	140N-m (1,240in.lbs.)
<b>Dimensions (L x W x H)</b> Dimensi 体积	161x66x205mm (6-3/8"x2-5/8"x8-1/8")
<b>Net Weight</b> Berat Bersih 淨重	1 - 1.2kg (2.3 - 2.7lbs.)
<b>Work Amount (approx.)</b> Jumlah Kerja 工作量	160 pcs with BL1021B High Tensile Bolt M12 Standard Fastening Torque at 100N.m

\* All list price shown are for reference only (exclude SST).

\* Semua harga yang ditunjukkan adalah untuk rujukan sahaja (tidak termasuk SST). 所有显示的建议零售价仅供参考 (不包括SST)。

Cordless Target Kord 无绳  
LED Flashlight Lampu Suluh LED LED 照明灯  
Vacuum Cleaner Pemilauhi VAKUUM 吸尘器  
Drilling / Fastening Druai / Pengait 钻式 / 紧固件  
Impact Drilling / Demolition Druai / Penembok 钻式钻式 / 拆墙加工  
Cutting Pemotong 切割机  
Grinding / Sanding Pengisar / Pencil 磨削 / 砂磨  
Sawing Gergaji 电锯  
Planing / Routing Pengisar / Tangkapan 刨削 / 磨削  
Others Lain-lain 其他  
Outdoor Power Equipment Alatan Kerja Luar 园具-户外  
Makita

12V<sub>max</sub>

CXT

Li-ion Ah 4.0 2.0 1.5

**TW060DZ** 6.35mm (1/4")  
RM 372

**Cordless Impact Wrench**  
Perengkuh Impak Tanpa Kord  
充电式冲击套筒扳手

- Electric brake for increased operator safety

Standard Equipment: Belt Clip

- Z: Without Charger & Battery



<b>Fastening Capacities</b> Kapasiti 能力	<b>Standard Bolt:</b> M8 - M12 (5/16" - 15/32")
<b>Square Drive</b> Batang Segi Empat 四方头	<b>High Tensile Bolt:</b> M6 - M10 (1/4" - 3/8")
<b>No Load Speed (RPM)</b> Kelajuan Tanpa Beban 回转数	0 - 2,600
<b>Impacts Per Minute (IPM)</b> Impak Per Minit 冲击数	0 - 3,200
<b>Max Fastening Torque</b> Maksimum Tenaga Pemutaran Pengancing 最快扭力	60N·m (530in.lbs.)
<b>Dimensions (L x W x H)</b> Dimensi 体积	161x66x205mm (6-3/8"x2-5/8"x8-1/8")
<b>Net Weight</b> Berat Bersih 淨重	1.0 - 1.2kg (2.2 - 2.6lbs.)

# Cordless Ratchet Wrench

Perengkuh Ratchet Tanpa Kord 充电式棘轮扳手

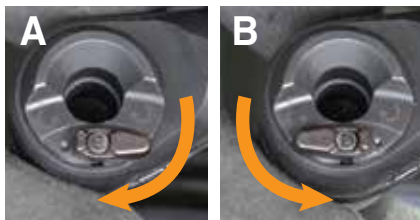

**Max Fastening Torque**  
Tenaga Pemutaran Pengancing Maksimum 最快扭转  
**47.5N·m**

**Forward / Reverse rotation change**  
Turn the reversing lever to the A side for clockwise rotation or to the B side for counterclockwise rotation  
Perubahan putaran maju / belakang 正转/反转变化



**LED job light**  
Lampu kerja LED  
LED工作灯

**Switch lever**  
Tukar tuil  
切换杆

**Compatible with variable sockets with socket adaptor**  
Sesuai dengan soket yang berubah-ubah dengan penyesuaian soket 与带有插座适配器的可变插座兼容



**Accessories (Optional)**  
Aksesori 配件



**Socket Adaptor 9.5mm (3/8")**  
Part No.191A50-3

**Socket Adaptor 6.35mm (1/4")**  
Part No.191A51-1

**Standard Equipment**  
Peralatan Standard  
标准装备



**Tool Bag (optional)**  
Part No. 832071-7

**Able to tighten 13mm nut onto M8 threaded rod**  
Kipas swing automatik  
自动摆



13mm nut only

**WR100DWA** | **WR100DZ** 9.5mm (3/8")  
RM1,605 | RM 1,222

**Cordless Ratchet Wrench**  
Perengkuh Ratchet Tanpa Kord  
充电式棘轮扳手

- Supplied with Two Socket Adaptors for Compatibility with a Variety of Sockets

Standard Equipment:  
Socket Adaptor 9.5mm & 6.35mm

- WA: 1x Standard Charger, 1x 2.0Ah Battery, 1x Tool Bag
- Z: Without Charger & Battery



<b>Capacity</b> Kapasiti 能力	<b>Standard Bolt:</b> M5 - M12 (3/16" - 1/2")
<b>Square Drive</b> Kepala Segi Empat 方形头	<b>High Tensile Bolt:</b> M5 - M10 (3/16" - 3/8")
<b>No Load Speed (RPM)</b> Kelajuan Tanpa Beban 回转数	0 - 800
<b>Max Fastening Torque</b> Tenaga Pemutaran Pengancing Maksimum 最快扭转	47.5N·m (420in.lbs.)
<b>Dimensions (L x W x H)</b> Dimensi 体积	341x67x63mm (13-7/16"x2-5/8"x2-1/2")
<b>Net Weight</b> Berat Bersih 淨重	1.0 - 1.2kg (2.3 - 2.7lbs.)

\* All list price shown are for reference only (exclude SST).  
\* Semua harga yang ditunjukkan adalah untuk rujukan sahaja (tidak termasuk SST). 所有显示的建议零售价仅供参考 (不包括SST)。

Cordless  
Target Aplikasi  
LED Flashlight  
Lampu Suhu LED  
LED照灯  
Vacuum Cleaner  
Pembersih Vakuum  
吸尘器  
Drilling / Fastening  
Ganda / Pengikat  
钻孔 / 紧固  
Impact Drilling / Demolition  
Ganda / Pemusnah  
冲击钻孔 / 摧毁施工  
Cutting  
Pemotong  
切割  
Grinding / Sanding  
Pengkilan / Poles  
研磨 / 打磨  
Sawing  
Gergaji  
锯切  
Planing / Routing  
Pergalisan / Tumpang  
刨削 / 压花  
Others  
Lain-lain  
其他  
Outdoor Power Equipment  
Alatan Kuat Luar  
园机/户外  
Makita  
1914T



**HR166DSMJ** | **HR166DWAJ** | **HR166DZ** 16mm (5/8")  
 RM 1,787 | RM 1,523 | RM 957

**Cordless Rotary Hammer**  
 Tukul Putar Tanpa Kord  
 充电式电钻



- 2-Mode operation for Rotation Only or Hammering with Rotation

Standard Equipment: Side Grip, Depth Gauge

- SMJ: 1x Speed Charger, 2x 4.0Ah Battery, 1x Makpac Connector Box
- WAJ: 1x Standard Charger, 2x 2.0Ah Battery, 1x Makpac Connector Box
- Z: Without Charger, Battery & Carrying Case



<b>Impact Energy</b> Kekuatan Impak 单次最大冲击力	EPTA-Procedure 05/2009: 1.1J Our experimental conditions: 1.0J
<b>Capacity</b> Kapasiti 能力	Concrete: 16mm (5/8")   Steel: 10mm (3/8")   Wood: 13mm (1/2")
<b>Impacts Per Minute (IPM)</b> Impak Per Minit 冲击数	0 - 4,800
<b>No Load Speed (RPM)</b> Kelajuan Tanpa Beban 回转数	0 - 680
<b>Dimensions (L x W x H)</b> Dimensi 体积	BL1021B: 250x74x187mm (9-7/8"x2-15/16"x7-3/8")
<b>Net Weight</b> Berat Bersih 净重	1.8 - 2.4kg (4.1 - 5.4lbs)
<b>Work Amount (approx.)</b> Jumlah Kerja 工作量	42 holes with BL1021B Mansory drill ø6mm (Concrete 40N/mm2 Depth 40mm)



HR166D

Models and specs may vary by country

**HR140DWYE1** 14mm (9/16")  
 RM 1,787

**Cordless Rotary Hammer**  
 Tukul Putar Tanpa Kord  
 充电式电钻



- 2-Mode operation for Rotation Only or Hammering with Rotation

Standard Equipment: Side Grip, Depth Gauge

- WYE1: 1x Standard Charger, 2x 1.5Ah Battery, Accessories Set



<b>Impact Energy</b> Kekuatan Impak 单次最大冲击力	EPTA-Procedure 05/2009: 1.0J Our experimental conditions: 0.9J
<b>Capacity</b> Kapasiti 能力	Concrete: 14mm (9/16")   Steel: 10mm (3/8")   Wood: 13mm (1/2")
<b>Impacts Per Minute (IPM)</b> Impak Per Minit 冲击数	0 - 4,900
<b>No Load Speed (RPM)</b> Kelajuan Tanpa Beban 回转数	0 - 850
<b>Dimensions (L x W x H)</b> Dimensi 体积	BL1021B: 246x74x179mm (9-11/16"x2-15/16"x7") BL1041B: 246x74x198mm (9-11/16"x2-15/16"x7-3/4")
<b>Net Weight</b> Berat Bersih 净重	1.9 - 2.6kg (4.3 - 5.6lbs)
<b>Work Amount (approx.)</b> Jumlah Kerja 工作量	32 holes with BL1021B Mansory drill ø6mm (Concrete 40N/mm2 Depth 40mm)

**TL064DSME** | **TL064DWAJ** | **TL064DZ**  
 RM 1,923 | RM 1,658 | RM 1,095

**Cordless Angle Impact Driver**  
 Pemutar Skru Impak Sudut  
 Tanpa Kord  
 充电式角向冲击螺丝起子机



- Compact & lightweight for fastening and loosening in tight spaces

Standard Equipment: Phillips Bit, Belt Clip

- SME: 1x Speed Charger, 2x 4.0Ah Battery
- WAE: 1x Standard Charger, 2x 2.0Ah Battery
- Z: Without Charger, Battery & Carrying Case



<b>Capacity</b> Kapasiti 能力	Machine Screw: M4 - M8 (5/32" - 5/16") Standard Bolt: M4 - M12 (5/32" - 1/2") High Tensile Bolt: M4 - M8 (5/32" - 5/16") Coarse thread (in length): 22 - 75mm (7/8" - 2-31/32") 6.35mm (1/4")
<b>Hex Shank</b> Batang Heksagon 六角柄	
<b>No Load Speed (RPM)</b> Kelajuan Tanpa Beban 回转数	0 - 2,000
<b>Impacts Per Minute (IPM)</b> Impak Per Minit 冲击数	0 - 3,000
<b>Max Fastening Torque</b> Maksimum Tenaga Pemutaran Pengancing 最快扭力	60N-m (530in.lbs.)
<b>Dimensions (L x W x H)</b> Dimensi 体积	361x66x86mm (14-1/4"x2-5/8"x3-3/8")
<b>Net Weight</b> Berat Bersih 净重	1.2 - 1.6kg (2.7 - 3.6lbs)
<b>Work Amount (approx.)</b> Jumlah Kerja 工作量	933 pcs with BL1021B Machine Screw M8 x 16mm

**TL065DSME** | **TL065DWAJ** | **TL065DZ**  
 RM 2,010 | RM 1,747 | RM 1,182

**Cordless Angle Impact Wrench**  
 Perengkuh Impak Sudut  
 Tanpa Kord  
 充电式角向冲击套筒扳手



- Compact & lightweight for fastening and loosening in tight spaces

Standard Equipment: Belt Clip

- SME: 1x Speed Charger, 2x 4.0Ah Battery
- WAE: 1x Standard Charger, 2x 2.0Ah Battery
- Z: Without Charger, Battery & Carrying Case



<b>Capacity</b> Kapasiti 能力	Standard Bolt: M4 - M12 (5/32" - 1/2") High Tensile Bolt: M4 - M8 (5/32" - 5/16") 9.5mm (3/8")
<b>Square Drive</b> Batang Segi Empat 四方头	
<b>No Load Speed (RPM)</b> Kelajuan Tanpa Beban 回转数	0 - 2,000
<b>Impacts Per Minute (IPM)</b> Impak Per Minit 冲击数	0 - 3,000
<b>Max Fastening Torque</b> Maksimum Tenaga Pemutaran Pengancing 最快扭力	60N-m (530in.lbs.)
<b>Dimensions (L x W x H)</b> Dimensi 体积	361x66x86mm (14-1/4"x2-5/8"x3-3/8")
<b>Net Weight</b> Berat Bersih 净重	1.2 - 1.6kg (2.7 - 3.6lbs)
<b>Work Amount (approx.)</b> Jumlah Kerja 工作量	933 pcs with BL1021B Machine Screw M8 x 16mm

**DA332DWAJ** | **DA332DZ** 10mm (3/8")  
 RM 1,223 | RM 658

**Cordless Angle Drill**  
 Gerudi Sudut Tanpa Kord  
 充电式角向电钻



- Up to 40% faster drilling and 380% longer runtime\*\*

Standard Equipment: Chuck Key, Chuck Key Holder, Phillips Bit, Belt Clip

- WAE: 1x Standard Charger, 2x 2.0Ah Battery
- Z: Without Charger, Battery & Carrying Case



<b>Capacity</b> Kapasiti 能力	Steel: 10mm (3/8") Wood: 12mm (1/2") 0 - 1,100
<b>No Load Speed (RPM)</b> Kelajuan Tanpa Beban 回转数	
<b>Head Height</b> Ketinggian Kepala 高度	63mm (2-1/2")
<b>Center Height</b> Pusat Tinggi 中心高度	23.5mm (15/16")
<b>Dimensions (L x W x H)</b> Dimensi 体积	BL1021B: 313x68x86mm (12-3/8"x2-11/16"x3-3/8") BL1041B: 332x68x86mm (13-1/8"x2-11/16"x3-3/8") 1.2 - 1.3kg (2.6 - 2.9lbs)
<b>Net Weight</b> Berat Bersih 净重	
<b>Work Amount (approx.)</b> Jumlah Kerja 工作量	600 pcs with BL1021B Wood Screw ø4.1 x 38mm

\* All list price shown are for reference only (exclude SST).

\*\* Semua harga yang ditunjukkan adalah untuk rujukan sahaja (tidak termasuk SST). 所有显示的建议零售价仅供参考 (不包括SST)。

Cordless Target Kord 无绳电钻  
 LED Flashlight Lampu Suluh LED LED 照明灯  
 Vacuum Cleaner Pembersih Vakuum 吸尘器  
 Drilling / Fastening Dredil / Pasang 钻孔 / 紧固  
 Impact Drilling / Demolition Dredil / Persekit 冲击钻孔 / 拆除加工  
 Cutting Pemotong 切割  
 Grinding / Sanding Pengisar / Pasir 研磨 / 打磨  
 Sawing Gergaji 锯切  
 Planing / Routing Pengisar / Tangkai 刨削 / 雕刻  
 Others Lain-lain 其他  
 Outdoor Power Equipment Alatan Kerja Luar 户外动力工具





**TM30DWA** RM 1,087 | **TM30DWAEX1** RM 1,200 | **TM30DZ** RM 522

**Cordless Multi Tool**  
Mesin Pemotong Berbilang Fungsi Tanpa Kord  
充电式多功能切割打磨机



- 12 Angle settings at every 30° from 0° to 360°

Standard Equipment: Hex Wrench

- WAE: 1x Standard Charger, 2x 2.0Ah Battery
- WAEX1: 1x Standard Charger, 2x 2.0Ah Battery, Accessories Set (Plunge Cut Saw Blade 28 (B-21353), Segment Saw Blade 85 (B-21325), Sanding Pad (B-46202))
- Z: Without Charger, Battery & Carrying Case



<b>Oscillations Per Minute (OPM)</b> Kelajuan Ayunan 摆动速度	6,000 - 20,000
<b>Oscillation Angle</b> Sudut Ayunan 摆动角度	Left: 1.6°   Right: 1.6°   Total: 3.2°
<b>Dimensions (L x W x H)</b> Dimensi 体积	277x65x98mm (10-7/8"x2-9/16"x3-7/8")
<b>Net Weight</b> Berat Bersih 净重	1.1 - 1.3kg (2.3 - 2.9lbs)
<b>Continuous Usage Time (approx.)</b> Masa Penggunaan Berterusan 连续使用时间	16 min with BL1021B

**CP100DWA** RM 885 | **CP100DZ** RM 502

**Cordless Multi Cutter**  
Pemotong Pelbagai Fungsi Tanpa Kord  
充电式多功能电剪



- Cuts thin and thick material up to 6mm such as cardboard, carpet, fabrics, leather, CD, DVD & Blu-ray

Standard Equipment: Blade

- WA: 1x Standard Charger, 1x 2.0Ah Battery, Tool Bag
- Z: Without Charger & Battery



<b>Max Cutting Capacity</b> Kapasiti Pemotongan Maksimum 最大切割能力	6mm (1/4")
<b>No Load Speed (RPM)</b> Kelajuan Tanpa Beban 回转数	300
<b>Dimensions (L x W x H)</b> Dimensi 体积	BL1021B: 272x66x120mm (10-3/4"x2-5/8"x4-3/4") BL1041B: 291x66x121mm (11-1/2"x2-5/8"x4-3/4")
<b>Net Weight</b> Berat Bersih 净重	0.72 - 0.88kg (1.6 - 1.9lbs)
<b>Work Amount (approx.)</b> Jumlah Kerja 工作量	800 m with BL1021B Cardboard Carton 5mm (T) 500mm (L)

# Cordless Threaded Rod Cutter

Pemotong Batang Keluli Tanpa Kord 充电式螺纹杆切割机

**Lightweight**  
Ringan 轻量  
**2.8kg**  
with BL1041B  
4.0Ah Battery

**Maximum Cutting Capacity**  
Kapasiti Pemotongan Maksimum 最大切割能力  
Mild Steel: **M10**  
Stainless Steel: **W3/8**

**LED job light**  
Lampu kerja LED LED工作灯

**Reversing switch lever**  
Tuas suis terbalik 反转变化开关杆

**Guide scale**  
Panjang hos 软管长度

**Compact motor section with overall length of 177mm**  
Bahagian motor padat dengan panjang keseluruhan 177mm 紧凑的电机全长177mm

**Metal hook**  
Cangkuk logam 金属挂钩

**Clean cut surface**  
Burr-free cuts allow for easy nut tightening  
Permukaan pemotong yang bersih untuk mengetatkan skru dengan mudah  
干净的切割表面易于拧紧螺母

**SC103DZJ** RM 6,083

**Cordless Threaded Rod Cutter**  
Pemotong Batang Keluli Tanpa Kord  
充电式螺纹杆切割机



- More Compact & High Productivity

Standard Equipment: Cutter Blade, Hex socket head bolt, Blade Cover, Depth Gauge, Thumb screw, Hex Wrench

- ZJ: With 1x Makpac Connector Box, Without Charger & Battery

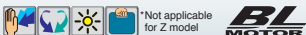

<b>Max Cutting Capacity</b> Kapasiti Pemotongan Maksimum 最大切割能力	Mild Steel: M10 Stainless Steel: W3/8
<b>Min. Cutting Length</b> Panjang Pemotongan Minimum 最小切割长度	20mm (13/16")
<b>Dimensions (L x W x H)</b> Dimensi 体积	180x107x289mm (7-1/8"x4-1/4"x11-3/8")
<b>Net Weight</b> Berat Bersih 净重	2.7 - 2.8kg (6.0 - 6.2lbs.)
<b>Work Amount (approx.)</b> Jumlah Kerja 工作量	550 pcs with BL1041B Mild Steel M10

\* All list price shown are for reference only (exclude SST).

\* Semua harga yang ditunjukkan adalah untuk rujukan sahaja (tidak termasuk SST). 所有显示的建议零售价仅供参考 (不包括SST)。

Cordless Targeted Jobs

LED Flashlight Lampu Suhu LED LED照明灯

Vacuum Cleaner Pembersih Vakuum 吸尘器

Drilling / Fastening Gergaji / Pasak 钻孔 / 紧固

Impact Drilling / Demolition Gergaji / Pasak 冲击钻孔 / 拆除施工

Cutting Pemotong 切割

Grinding / Sanding Pengkilan / Pasak 研磨 / 打磨

Sawing Gergaji 锯切

Planing / Routing Pengkilan / Pasak 刨削 / 雕刻

Others Lain-lain 其他

Outdoor Power Equipment Alatan Kuat Luar 户外动力设备



12V<sub>max</sub>

CXT

Li-ion Ah 4.0 2.0 1.5

**CC301DWME** RM 1,513 | **CC301DWAE** RM 1,332 | **CC301DZ** 85mm (3-3/8") RM 765

**Cordless Cutter**  
Pemotong Tanpa Kord  
充电式切割机



- Designed for cutting glass and ceramic tile

**Standard Equipment:** Diamond Wheel, Water Supply Tank Assembly, Hex Wrench

- WME: 1x Standard Charger, 2x 4.0Ah Battery
- WAE: 1x Standard Charger, 2x 2.0Ah Battery
- Z: Without Charger, Battery & Carrying Case



<b>Blade Diameter</b> Diameter Bilah 锯片直径	85mm (3-3/8")
<b>Max Cutting Capacity</b> Kapasiti Pemotongan Maksimum 最大切割能力	90°: 25.5mm (1") 45°: 16.5mm (5/8")
<b>No Load Speed (RPM)</b> Kelajuan Tanpa Beban 回转数	1,600
<b>Tank Capacity</b> Kapasiti Tangki 水箱容量	Water : 0.5L
<b>Dimensions (L x W x H)</b> Dimensi 体积	313x170x125mm (12-3/8"x6-11/16"x4-7/8")
<b>Net Weight</b> Berat Bersih 淨重	1.9kg (4.1lbs)
<b>Work Amount (approx.)</b> Jumlah Kerja 工作量	1.5 pcs with BL1021B Diamond Blade, Glass 10 x 300mm

**HS301DSME** RM 1,368 | **HS301DWAE** RM 1,105 | **HS301DZ** 85mm (3-3/8") RM 540

**Cordless Circular Saw**  
Gergaji Piring Tanpa Kord  
充电式圆锯



- Fast cutting of plywood, MDF, pegboard, particleboard, melamine, drywall and more

**Standard Equipment:** TCT Saw Blade (B-14607), Hex Wrench

- SME: 1x Speed Charger, 2x 4.0Ah Battery
- WAE: 1x Standard Charger, 2x 2.0Ah Battery
- Z: Without Charger, Battery & Carrying Case



<b>Blade Diameter</b> Diameter Bilah 锯片直径	85mm (3-3/8")
<b>Max Cutting Capacity</b> Kapasiti Pemotongan Maksimum 最大切割能力	90°: 25.5mm (1") 45°: 16.5mm (5/8")
<b>No Load Speed (RPM)</b> Kelajuan Tanpa Beban 回转数	1,500
<b>Dimensions (L x W x H)</b> Dimensi 体积	313x170x155mm (12-3/8"x6-11/16"x6-1/8")
<b>Net Weight</b> Berat Bersih 淨重	1.6 - 1.7kg (3.5 - 3.8lbs)
<b>Work Amount (approx.)</b> Jumlah Kerja 工作量	140 cuts with BL1021B Sawing (SPF 1"x4" 0 Degree Cut)

**SD100DAJ** RM 1,905 | **SD100DZ** RM 1,340

**Cordless Drywall Saw**  
Gergaji Drywall Tanpa Kord  
充电式石膏板切割机



- Ideal for cutting holes in drywalls when setting ceiling lights, air vents etc

**Standard Equipment:** Blade, Blade Cover, Base Cover, Hex Wrench

- WAJ: 1x Standard Charger, 2x 2.0Ah Battery, 1x Makpac Connector Box
- Z: Without Charger, Battery & Carrying Case



<b>Strokes Per Minute (SPM)</b> Kelajuan Strok 冲程速度	0 - 6,000
<b>Length of Stroke</b> Panjang Strok 冲程长度	6mm (1/4")
<b>Capacity</b> Kapasiti 能力	Drywall: 30mm (1-3/16") Wood: 15mm (9/16")
<b>Dimensions (L x W x H)</b> Dimensi 体积	239x79x266mm (9-3/8"x3-1/8"x10-1/2")
<b>Net Weight</b> Berat Bersih 淨重	1.4 - 1.6kg (3.2 - 3.5lbs)
<b>Work Amount (approx.)</b> Jumlah Kerja 工作量	50 m with BL1021B Cutting (Gypsum Board Thickness 9.5mm/ 2ply)

**JV101DWAE** RM 1,050 | **JV101DWYE** RM 995 | **JV101DZ** RM 485

**Cordless Jig Saw**  
Gergaji Jig Tanpa Kord  
充电式线锯机



- Aluminum die-cast base adjusts from 0°-45° right to left

**Standard Equipment:** Jig Saw Blade B-10 (A-85628), Hex Wrench

- WAE: 1x Standard Charger, 2x 2.0Ah Battery
- WYE: 1x Standard Charger, 2x 1.5Ah Battery
- Z: Without Charger, Battery & Carrying Case



<b>Max Cutting Capacity at 90°</b> Kapasiti Pemotongan Maksimum 最大切割能力	Wood: 65mm (2-9/16") Aluminum: 4mm (5/32") Mild Steel: 2mm (1/16")
<b>Length of Stroke</b> Panjang Strok 冲程长度	18mm (11/16")
<b>Strokes Per Minute (SPM)</b> Kelajuan Strok 冲程速度	0-2,900
<b>Dimensions (L x W x H)</b> Dimensi 体积	232x76x196mm (9-1/8"x3"x7-3/4")
<b>Net Weight</b> Berat Bersih 淨重	1.8 - 1.9kg (3.9 - 4.3lbs)
<b>Work Amount (approx.)</b> Jumlah Kerja 工作量	60 pcs with BL1021B Sawing (Plywood 300mm Long x 12mm thickness)

**JV103DSMJ** RM 1,838 | **JV103DAJ** RM 1,573 | **JV103DZ** RM 1,008

**Cordless Jig Saw**  
Gergaji Jig Tanpa Kord  
充电式线锯机



- Up to 2.2X Faster Cutting & 2.2X Longer Runtime\*\*

**Standard Equipment:** Jig Saw Blade B-10 (A-85628), Hex Wrench

- SMJ: 1x Speed Charger, 2x 4.0Ah Battery, 1x Makpac Connector Box
- WAJ: 1x Standard Charger, 2x 2.0Ah Battery, 1x Makpac Connector Box
- Z: Without Charger, Battery & Carrying Case



JV102D/103D

MODES AND SPEEDS  
MAY VARY BY COUNTRY

<b>Max Cutting Capacity at 90°</b> Kapasiti Pemotongan Maksimum 最大切割能力	Wood: 90mm (3-1/2") Aluminum: 20mm (13/16") Mild Steel: 10mm (3/8")
<b>Length of Stroke</b> Panjang Strok 冲程长度	23mm (7/8")
<b>Strokes Per Minute (SPM)</b> Kelajuan Strok 冲程速度	800 - 3,000
<b>Dimensions (L x W x H)</b> Dimensi 体积	237x76x206mm (9-3/8"x3"x8-1/8")
<b>Net Weight</b> Berat Bersih 淨重	1.9 - 2.0kg (4.1 - 4.4lbs)
<b>Work Amount (approx.)</b> Jumlah Kerja 工作量	90 pcs with BL1021B Sawing (Plywood 300mm Long x 12mm thickness)

\* All list price shown are for reference only (exclude SST).

\* Semua harga yang ditunjukkan adalah untuk rujukan sahaja (tidak termasuk SST). 所有显示的建议零售价仅供参考 (不包括SST)。

Cordless  
Tanpa Kord 无线式

LED Flashlight  
Lampu Suluh LED  
LED 照明灯

Vacuum Cleaner  
Pembersih Vakuam  
吸尘器

Drilling / Fastening  
Drauli / Pasang  
钻孔 / 紧固

Impact Drilling / Demolition  
Drauli / Penanggal  
起工钻孔 / 拆墙加工

Cutting  
Pemotong  
切割

Grinding / Sanding  
Pengamir / Pasir  
磨削 / 打磨

Sawing  
Gergaji  
锯切

Planing / Routing  
Pengamir / Tangkap  
刨削 / 雕刻

Others  
Lain-lain  
其他

Outdoor Power Equipment  
Alatan Kerja Luar  
园具-户外

Makita  
MAKITA

12V<sub>max</sub>

CXT

Li-ion Ah 4.0 2.0 1.5

**JV102DZ**

RM 1,008

**Cordless Jig Saw**  
Gergaji Jig Tanpa Kord  
充电式线锯机



- Up to 2.2X Faster Cutting & 2.2X Longer Runtime\*

Standard Equipment:  
Jig Saw Blade B-10 (A-85628), Hex Wrench

- Z: Without Charger & Battery



VIDEO CLIP  
Models and specs may vary by country



<b>Max Cutting Capacity at 90°</b> Kapasiti Pemotongan Maksimum 最大切割能力	<b>Wood:</b> 90mm (3-1/2") <b>Aluminum:</b> 20mm (13/16") <b>Mild Steel:</b> 10mm (3/8")
<b>Length of Stroke</b> Panjang Strok 冲程长度	23mm (7/8")
<b>Strokes Per Minute (SPM)</b> Kelajuan Strok 冲程速度	800 - 3,000
<b>Dimensions (L x W x H)</b> Dimensi 体积	237x76x186mm (9-3/8"x3"x7-3/8")
<b>Net Weight</b> Berat Bersih 净重	1.8 - 1.9kg (3.9 - 4.2lbs)
<b>Work Amount (approx.)</b> Jumlah Kerja 工作量	290 pcs with BL1021B Sawing (Plywood 300mm Long x 12mm thickness)

**PT354DZ**

RM 2,378

**Cordless Pin Nailer**  
Mesin Pemaku Tanpa Kord  
充电式打钉机



- Ergonomically designed handle with soft grip provides increased comfort

Standard Equipment: Nose Adapter, Safety Goggles, Belt Clip, Hex Wrench

- Z: Without Charger & Battery



<b>Capacity</b> Kapasiti 能力	<b>Length:</b> 15, 18, 25, 30, 35mm (5/8", 11/16", 1", 1-3/16", 1-3/8") <b>Dia.:</b> 0.6mm (1/32") <b>Gauge:</b> 23Ga
<b>Magazine Capacity</b> Bilangan Staples 装订个数	120
<b>Dimensions (L x W x H)</b> Dimensi 体积	231x66x226mm (9-1/8"x2-5/8"x8-7/8")
<b>Net Weight</b> Berat Bersih 净重	1.8 - 2.0kg (4.0 - 4.4lbs)
<b>Work Amount (approx.)</b> Jumlah Kerja 工作量	1333 pcs with BL1021B Pin nail
<b>Accessories (optional)</b>	
<b>Description</b>	<b>Size</b> <b>Pcs/ Box</b> <b>Part No.</b>
Pin Nail 18mm (11/16")	P18    10,000    F-31825
Pin Nail 25mm (1")	P25    10,000    F-31838
Pin Nail 30mm (1-3/16")	P30    10,000    F-31841
Pin Nail 35mm (1-3/8")	P35    10,000    F-31854

**ST113DWAJ | ST113DZ**

RM 2,553

RM 1,987

**Cordless Stapler**  
Stapler Tanpa Kord  
充电式钉枪



- Compact and lightweight for reduced operator fatigue

Standard Equipment:  
Safety Goggles (195246-2), Belt Clip

- WAJ: 1x Standard Charger, 2x 2.0Ah Battery, 1x Makpac Connector Box
- Z: Without Charger, Battery & Carrying Case



\*Not applicable for Z model

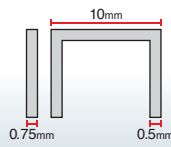

<b>Staple</b> Staple 钉种	<b>Width:</b> 10mm (3/8") <b>Length:</b> 7 - 10mm(9/32" - 3/8") <b>Gauge:</b> 0.5 x 0.7mm
<b>Magazine Capacity</b> Bilangan Staples 装订个数	150 (max 160)
<b>Dimensions (L x W x H)</b> Dimensi 体积	211x81x159mm (8-5/16"x3-3/16"x6-1/4")
<b>Net Weight</b> Berat Bersih 净重	1.3kg (2.9lbs.)
<b>Work Amount (approx.)</b> Jumlah Kerja 工作量	2666 pcs with BL1021B Stapler width 10mm
<b>Accessories (optional)</b>	
<b>Description</b>	<b>Length</b> <b>Pcs/ Box</b> <b>Part No.</b>
Staple RT10mm	10mm    15,000    F-81521
Staple RT7mm	7mm    25,000    F-81518

**CG100DZA**

RM 1,383

**Cordless Caulking Gun**  
Alat Tembak Silikon Tanpa Kord  
充电式填缝枪



- 5 Speed dial optimizes flow rate 0 - 28mm/sec

Standard Equipment: Holder, Holder Joint, Piston, Rack 42, Safety Goggles

- ZA: Without Charger & Battery



VIDEO CLIP  
Models and specs may vary by country

<b>Max Dispersing Force</b> Tujahan Maksimum 最大推力	5,000N (1,100lbs)
<b>No Load Speed</b> Kelajuan Tanpa Beban 回转数	0 - 28mm/sec. (0 - 66in/min.)
<b>Holder Size</b> Kapasiti 容量	300mL (Optional Accessories 600mL, 800mL Holder)
<b>Dimensions (L x W x H)</b> Dimensi 体积	404x108x259mm (15-7/8"x4-1/4"x10-1/4")
<b>Net Weight</b> Berat Bersih 净重	1.9 - 2.6kg (4.2 - 5.8lbs)
<b>Work Amount (approx.)</b> Jumlah Kerja 工作量	150 pcs with BL1016 300ml silicon sealant

**JR105DWAJ | JR105DZ**

RM 1,070

RM 505

**Cordless Recipro Saw**  
Gergaji Resipro Tanpa Kord  
充电式往复锯



- Cuts PVC, ABS pipe, EMT, drywall, wood & more

Standard Equipment: Hex Wrench, Recipro Saw Blades 2pcs (B-20404 & B-20432)

- WAE: 1x Standard Charger, 2x 2.0Ah Battery
- Z: Without Charger, Battery & Carrying Case



\*Not applicable for Z model

<b>Length of Stroke</b> Panjang Strok 冲程长度	13mm (1/2")
<b>Strokes Per Minute (SPM)</b> Kelajuan Strok 冲程速度	0 - 3,300
<b>Capacity</b> Kapasiti 能力	<b>Pipe:</b> 50mm (2") <b>Wood:</b> 50mm (2")
<b>Dimensions (L x W x H)</b> Dimensi 体积	376x66x186mm (14-3/4"x2-5/8"x7-3/8")
<b>Net Weight</b> Berat Bersih 净重	1.3 - 1.5kg (2.9 - 3.2lbs)
<b>Work Amount (approx.)</b> Jumlah Kerja 工作量	45 pcs with BL1021B Cutting (PVC plastic hose 48mm)

\* All list price shown are for reference only (exclude SST).

\* Semua harga yang ditunjukkan adalah untuk rujukan sahaja (tidak termasuk SST). 所有显示的建议零售价仅供参考 (不包括SST)。

Cordless  
Target: Wood, Metal, Plastic

LED Flashlight  
Lampu Suluh LED  
LED手电筒

Vacuum Cleaner  
Pembersih Vakuum  
吸尘器

Drilling / Fastening  
Gergaji / Pengikat  
钻孔 / 紧固

Impact Drilling / Demolition  
Gergaji / Pemusnah  
冲击钻孔 / 拆毁

Cutting  
Pemotong  
切割

Grinding / Sanding  
Pengiraian / Poles  
研磨 / 砂磨

Sawing  
Gergaji  
锯切

Planing / Routing  
Pengiraian / Tumpang  
刨削 / 压边

Others  
Lain-lain  
其他

Outdoor Power Equipment  
Alatan Kuat Luar  
户外动力工具





**UH353DWA** 350mm (13-3/4")  
RM 1,095

**Cordless Hedge Trimmer**  
Pemangkas Tanaman Pagar  
Tanpa Kord  
充电式篱笆修剪机

- Lightweight. Low Vibration. Low Noise

Standard Equipment: Blade Cover

- WA: 1x Standard Charger, 1x 2.0Ah Battery



<b>Blade Length</b> Panjang bilah 刀片长度	350mm (13-3/4")
<b>Tooth Spacing</b> Selang Gigi 牙齿间隔	28mm (1-1/8")
<b>Max Cutting Capacity</b> Kapasiti Pemotongan Maksimum 最大切割能力	15mm (9/16")
<b>Strokes Per Minute (SPM)</b> Kelajuan Strok 冲程速度	3,300
<b>Dimensions (L x W x H)</b> Dimensi 体积	693x175x165mm (27-1/4"x6-7/8"x6-1/2")
<b>Net Weight</b> Berat Bersih 淨重	1.9 - 2.1 kg (4.2 - 4.5 lbs.)
<b>Continuous Usage Time</b> Masa Penggunaan Berterusan 连续使用时间	40 min with BL1021B

**UH201DWAX** | **UH201DZ** 200mm (7-7/8")  
RM 915 | RM 450

**Cordless Hedge Trimmer**  
Pemangkas Tanaman Pagar  
Tanpa Kord  
充电式篱笆修剪机

- Dual blade action cuts quickly with a shearing effect

Standard Equipment: Blade Cover, Chip Receiver

- WAX: 1x Standard Charger, 1x 2.0Ah Battery, 1x Grass Shear Blade, 1x Grass Receiver
- Z: Without Charger & Battery



<b>Blade Length</b> Panjang Bilah 刀片长度	200mm (7-7/8")
<b>Tooth Spacing</b> Selang Gigi 牙齿间隔	26mm (1")
<b>Strokes Per Minute (SPM)</b> Kelajuan Strok 冲程速度	2,500
<b>Dimensions (L x W x H)</b> Dimensi 体积	504x120x131mm (19-7/8"x4-3/4"x5-1/8")
<b>Net Weight</b> Berat Bersih 淨重	1.3 - 1.5kg (2.8 - 3.3lbs)
<b>Continuous Usage Time (approx.)</b> Masa Penggunaan Berterusan 连续使用时间	45 min with BL1021B

**UM600DWA** | **UM600DZ** 160mm (6-5/16")  
RM 940 | RM 557

**Cordless Grass Shear**  
Pemotong Rumput Tanpa Kord  
充电式割草机

- 2 in 1: Both trimmer blade and shear blade can be attached

Standard Equipment: Grass Receiver, Blade Cover

- WA: 1x Standard Charger, 1x 2.0Ah Battery
- Z: Without Charger & Battery



<b>Cutting Width</b> Lebar Keratan 切割宽度	160mm (6-5/16")
<b>Depth Adjustment</b> Pelarasan Kedalaman 深度调整	15mm (9/16")   20mm (13/16")   25mm (1")
<b>Strokes Per Minute (SPM)</b> Kelajuan Strok 冲程速度	2,500
<b>Dimensions (L x W x H)</b> Dimensi 体积	329x177x131mm (13"x7"x5-1/8")
<b>Net Weight</b> Berat Bersih 淨重	1.3 - 1.5kg (2.8 - 3.3lbs)
<b>Continuous Usage Time (approx.)</b> Masa Penggunaan Berterusan 连续使用时间	45 min with BL1021B

**UR100DSME** | **UR100DZ**  
RM 1,457 | RM 628

**Cordless Grass Trimmer**  
Pemotong Rumput tanpa Kord  
充电式割草机

- Well balanced design with fully adjustable features to suit any operator

Standard Equipment: Band Assembly, Nylon Cutting Head, Nylon Cord, Accessory Bag, Hex Wrench

- SME: 1x Speed Charger, 2x 4.0Ah Battery
- Z: Without Charger & Battery



<b>Cutting Width</b> Lebar Keratan 切割宽度	Nylon Cutting Head: 260mm (10") Plastic Blade: 230mm (9")
<b>No Load Speed (RPM)</b> Kelajuan Tanpa Beban 回转数	Nylon Cutting Head: 9,000 Plastic Blade: 10,000
<b>Spindle Size</b> Saiz Spindel 主轴尺寸	M8 x 1.25RH
<b>Dimensions (L x W x H)</b> Dimensi 体积	835 - 1,185x267x210 - 315mm (32-7/8 - 46-2/3"x10-1/2"x8-1/4 - 12-1/3")
<b>Net Weight</b> Berat Bersih 淨重	2.1 - 2.3kg (4.4 - 4.9lbs.)
<b>Continuous Usage Time (approx.)</b> Masa Penggunaan Berterusan 连续使用时间	27 min with BL1021B

**MP100DZ**  
RM 532

**Cordless Inflator**  
Inflator Tanpa Kord  
充电式打气机

- Inflates the Tires of Cars, Bikes, Sport Balls, etc

Standard Equipment: British Adapter, French Adapter, Ball Adapter, Swim Ring Adapter

- Z: Without Charger & Battery



VIDEO CLIP  
Models and specs may vary by country



<b>Max Air Pressure</b> Udara Tekanan Maksimum 最大气压	830kPa (121 PSI) [8.3 bar]
<b>Air Discharge Amount</b> Pelepasan Udara 空气排放量	200kPa: 10L/min
<b>Hose Length</b> Panjang Hos 软管长度	65cm (25-1/2")
<b>Dimensions (L x W x H)</b> Dimensi 体积	235x74x173mm (9-1/4"x2-15/16"x6-13/16")
<b>Net Weight</b> Berat Bersih 淨重	1.2 - 1.3kg (2.6 - 3.0lbs.)
<b>Work Amount (approx.)</b> Jumlah Kerja 工作量	2 tires with BL1610 (16" Car Tires 215/60R16)

\* All list price shown are for reference only (exclude SST).

\* Semua harga yang ditunjukkan adalah untuk rujukan sahaja (tidak termasuk SST). 所有显示的建议零售价仅供参考 (不包括SST)。

Cordless Target Kord 无绳式  
LED Flashlight Lampu Suluh LED LED 照明灯  
Vacuum Cleaner Pemilauhi Vakuim 吸尘器  
Drilling / Fastening Dremel / Pengikat 钻头 / 紧固件  
Impact Drilling / Demolition Ganda / Penumbuh 起工钻头 / 拆墙加工  
Cutting Pemotong 切割  
Grinding / Sanding Pengisar / Poles 研磨 / 打磨  
Sawing Ganda 锯切  
Planing / Routing Pengisar / Tangkai 刨削 / 磨床  
Others Lain-lain 其他  
Outdoor Power Equipment Alatan Kerja Luar 园具-户外





12V<sub>max</sub>

CXT

Li-ion Ah 4.0 2.0 1.5

# Rechargeable Line Laser

Mesin Garis Laser Tanpa Kord 充电式激光水平仪



**High brightness green laser for increased visibility at bright site**

Laser hijau kecerahan tinggi 高亮度绿色激光

**SK209GDZ SK312GDZ GREEN**  
RM 7,065 RM 8,338

## Rechargeable Green Multi Line Laser

Mesin Garis Laser Tanpa Kord  
充电式激光水平仪



- Horizontal line - 2-Vertical line - 2-Vertical line/horizontal line (SK209GD)
- Horizontal line - Horizontal/vertical line - 3-Vertical line/horizontal line (SK312GD)

Standard Equipment: Laser Viewing Glass, Shoulder Strap, Storage Case

• Z : Without Charger & Battery



**SK106DZ RED SK106GDZ GREEN**  
RM 2,015 RM 3,408

## Rechargeable Red 4-point Cross Line Laser

Mesin Garis Laser Tanpa Kord  
充电式激光水平仪



- Brightness selection: 2 Modes (Bright mode/ Eco mode)

Standard Equipment: Soft Bag, Target Plate

• Z : Without Charger & Battery



**SK105DZ RED SK105GDZ GREEN**  
RM 1,192 RM 2,340

## Rechargeable Red Cross Line Laser

Mesin Garis Laser Tanpa Kord  
充电式激光水平仪



- Brightness selection: 2 Modes (Bright mode/ Eco mode)

Standard Equipment: Soft Bag, Target Plate

• Z : Without Charger & Battery



Horizontal / 2-Vertical lines

SK209GD

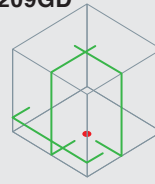

Horizontal / 3-Vertical lines

SK312GD

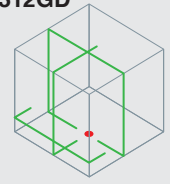

Cross line + Point

SK106D

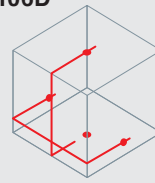

SK106GD

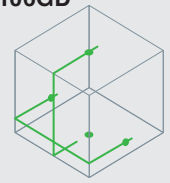

Cross line

SK105D



SK105GD



<b>Leveling Accuracy</b> Menunjukkan Ketepatan 指示精确度	±1mm/ 10m
<b>Self-leveling Range</b> Julat Indikasi Menegak 垂直指示范围	±2°
<b>Laser Fan Angle</b> Sudut Peminat Laser 激光扇角	Horizontal: 110°/ Vertical: 130°
<b>Number of Laser Lines</b> Bilangan Garisan Laser 激光线数量	3
<b>Laser Type</b> Jenis Laser 激光类型	Laser class 2: 515nm
<b>Tripod Thread</b> Tripod 脚架	5/8"
<b>Protection Class</b> Tahap Perlindungan 保护等级	IP54
<b>Dimensions (L x W x H)</b> Dimensi 体积	BL1021B: 122x110x225mm
<b>Net Weight</b> Berat Bersih 净重	1.5 - 1.6kg (3.3 - 3.5lbs)
<b>Continuous Usage Time (approx.)</b> Masa Penggunaan Berterusan 连续使用时间	7.5 - 20 hrs with BL1021B SK209GD 5 - 14 hrs with BL1021B SK312GD

<b>Measuring Range</b> Jarak Mengukur 测量范围	Up to: 25m SK106D Up to: 35m SK106GD
<b>Measuring Range w/ detector</b> Jarak Mengukur 测量范围	Up to: 80m
<b>Leveling Accuracy</b> Menunjukkan Ketepatan 指示精确度	±3mm/ 10m
<b>Self-leveling Range</b> Julat Indikasi Menegak 垂直指示范围	±4°
<b>Laser Fan Angle</b> Sudut Peminat Laser 激光扇角	Horizontal: 180°/ Vertical: 170°
<b>Number of Laser</b> Bilangan Laser 激光数量	Points : 4 Lines : 2
<b>Laser Type</b> Jenis Laser 激光类型	Laser class 2: 635nm SK106D Laser class 2: 525nm SK106GD
<b>Dimensions (L x W x H)</b> Dimensi 体积	138x64x102mm (5-7/16"x2-1/2"x4")
<b>Net Weight</b> Berat Bersih 净重	0.69 - 0.85kg (1.5 - 1.9lbs.)
<b>Continuous Usage Time (approx.)</b> Masa Penggunaan Berterusan 连续使用时间	7.5 - 20 hrs with BL1021B SK106D 3.5 - 10 hrs with BL1021B SK106GD

<b>Measuring Range</b> Jarak Mengukur 测量范围	Up to: 25m SK105D Up to: 35m SK105GD
<b>Measuring Range w/ detector</b> Jarak Mengukur 测量范围	Up to: 80m
<b>Leveling Accuracy</b> Menunjukkan Ketepatan 指示精确度	±3mm/ 10m
<b>Self-leveling Range</b> Julat Indikasi Menegak 垂直指示范围	±4°
<b>Laser Fan Angle</b> Sudut Peminat Laser 激光扇角	Horizontal: 180°/ Vertical: 160°
<b>Number of Laser Lines</b> Bilangan Garisan Laser 激光线数量	2
<b>Laser Type</b> Jenis Laser 激光类型	Laser class 2: 635nm SK105D Laser class 2: 525nm SK105GD
<b>Dimensions (L x W x H)</b> Dimensi 体积	138x64x102mm (5-7/16"x2-1/2"x4")
<b>Net Weight</b> Berat Bersih 净重	0.67 - 0.84 kg (1.5 - 1.9 lbs.)
<b>Continuous Usage Time (approx.)</b> Masa Penggunaan Berterusan 连续使用时间	7.5 - 20 hrs with BL1021B SK105D 3.5 - 10 hrs with BL1021B SK105GD

\* All list price shown are for reference only (exclude SST).

\* Semua harga yang ditunjukkan adalah untuk rujukan sahaja (tidak termasuk SST). 所有显示的建议零售价仅供参考 (不包括SST)。

Cordless Target Auto Focus

LED Flashlight Lampu Suhu LED LED 闪光灯

Vacuum Cleaner Pembersih Vakuum 吸尘器

Drilling / Fastening Gergaji / Pengikat 钻孔 / 紧固

Impact Drilling / Demolition Gergaji / Pemusnah 冲击钻孔 / 拆墙施工

Cutting / Routing Pemotong / 切割

Grinding / Sanding Penggosok / Poles 打磨 / 砂磨

Sawing Gergaji 锯切

Planing / Routing Penggosok / Tergosok 打磨 / 磨光

Others Lain-lain 其他

Outdoor Power Equipment Alatan Kuat Luar 户外动力工具



10.8V

Li-ion Ah 1.3

# Cordless Hammer Driver Drill

Tukul Pemutar Skru Bergerudi Tanpa Kord 充电式冲击螺丝起子电钻



**DRILLING**  
Penggerudian 钻孔

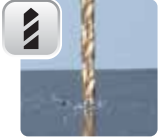

**FASTENING**  
Pengetat 紧固



**HAMMER DRILLING**  
Tukul Bergerudi 冲击电钻



**HP330DWE** 10mm (3/8")  
RM 877

**Cordless Hammer Driver Drill**  
Tukul Pemutar Skru Bergerudi Tanpa Kord  
充电式冲击螺丝起子电钻



- Hammer drill mode

Standard Equipment: Phillips Bit, Holster  
• WE: 1x Standard Charger, 2x 1.3Ah Battery



<b>Capacity</b> Kapasiti 能力	Steel: 10mm (3/8")   Wood: 21mm (13/16")   Masonry: 8mm (5/16")
<b>Impacts Per Minute (IPM)</b> Impak Per Minit 冲击数	High: 0-22,500 Low: 0-6,000
<b>No Load Speed (RPM)</b> Kelajuan Tanpa Beban 回转数	High: 0-1,500 Low: 0-400
<b>Max Fastening Torque</b> Maksimum Tenaga Pemutaran Pengancing 最快扭力	Hard: 24N·m   Soft: 12N·m
<b>Max Lock Torque</b> Pemutaran Tenaga Maksimum 最大扭力	22N·m (200in.lbs.)
<b>Dimensions (L x W x H)</b> Dimensi 体积	201x53x183mm (7-7/8"x2-1/16"x7-1/4")
<b>Net Weight</b> Berat Bersih 淨重	1.1kg (2.3lbs)
<b>Work Amount (approx.)</b> Jumlah Kerja 工作量	220 holes with BL1013 Auger Bit Drilling Ø9mm, Melapi 30mm Thickness

**DF330DWE** 10mm (3/8")  
RM 687

**Cordless Driver Drill**  
Gerudi Pemutar Skru Tanpa Kord  
充电式螺丝起子电钻



- 2-Speed design driver drill

Standard Equipment: Phillips Bit, Holster  
• WE: 1x Standard Charger, 2x 1.3Ah Battery



<b>Capacity</b> Kapasiti 能力	Steel: 10mm (3/8") Wood: 21mm (13/16")
<b>No Load Speed (RPM)</b> Kelajuan Tanpa Beban 回转数	High: 0-1,300 Low: 0-350
<b>Max Fastening Torque</b> Maksimum Tenaga Pemutaran Pengancing 最快扭力	Hard: 24N·m   Soft: 14N·m
<b>Max Lock Torque</b> Pemutaran Tenaga Maksimum 最大扭力	22N·m (200in.lbs.)
<b>Dimensions (L x W x H)</b> Dimensi 体积	189x53x183mm (7-7/16"x2-1/16"x7-1/4")
<b>Net Weight</b> Berat Bersih 淨重	1kg (2.2lbs)
<b>Work Amount (approx.)</b> Jumlah Kerja 工作量	220 holes with BL1013 Auger Bit Drilling Ø9mm, Melapi 30mm Thickness

**DF030DWE** 10mm (3/8")  
RM 665

**Cordless Driver Drill**  
Gerudi Pemutar Skru Tanpa Kord  
充电式螺丝起子电钻



- 18 clutch settings and drill mode for added fastening control

Standard Equipment: Phillips Bit, Holster  
• WE: 1x Standard Charger, 2x 1.3Ah Battery



<b>Capacity</b> Kapasiti 能力	Steel: 10mm (3/8") Wood: 21mm (13/16")
<b>No Load Speed (RPM)</b> Kelajuan Tanpa Beban 回转数	High: 0-1,300 Low: 0-350
<b>Max Fastening Torque</b> Maksimum Tenaga Pemutaran Pengancing 最快扭力	Hard: 24N·m   Soft: 14N·m
<b>Max Lock Torque</b> Pemutaran Tenaga Maksimum 最大扭力	22N·m (200 in.lbs.)
<b>Dimensions (L x W x H)</b> Dimensi 体积	157x53x183mm (6-3/16"x2-1/16"x7-1/4")
<b>Net Weight</b> Berat Bersih 淨重	0.89kg (2.0lbs)
<b>Work Amount (approx.)</b> Jumlah Kerja 工作量	190 holes with BL1013 Wood Drill ø9mm

**TD090DWE**  
RM 755

**Cordless Impact Driver**  
Pemutar Skru Impak Tanpa Kord  
充电式冲击螺丝起子机



- Compact bit sleeve 1/4" drive

Standard Equipment: Holster  
• WE: 1x Standard Charger, 2x 1.3Ah Battery



<b>Capacity</b> Kapasiti 能力	Machine Screw: M4 - M8mm (5/32" - 5/16") Standard Bolt: M5 - M12 (3/16" - 1/2") High Tensile Bolt: M5 - M10 (3/16" - 3/8") Coarse thread (in length): 22 - 90mm (7/8" - 3-1/2")
<b>No Load Speed (RPM)</b> Kelajuan Tanpa Beban 回转数	0-2,400
<b>Impacts Per Minute (IPM)</b> Impak Per Minit 冲击数	0-3,000
<b>Max Fastening Torque</b> Maksimum Tenaga Pemutaran Pengancing 最快扭力	90N·m (800in.lbs.)
<b>Dimensions (L x W x H)</b> Dimensi 体积	155x54x178mm (6-1/8"x2-1/8"x7")
<b>Net Weight</b> Berat Bersih 淨重	0.92kg (2.0lbs)
<b>Work Amount (approx.)</b> Jumlah Kerja 工作量	550 pcs with BL1013 Bolts M8 x 16mm

\* All list price shown are for reference only (exclude SST).

\* Semua harga yang ditunjukkan adalah untuk rujukan sahaja (tidak termasuk SST). 所有显示的建议零售价仅供参考 (不包括SST)。

LED Flashlight  
Lampu Suluh LED  
LED手电筒

Vacuum Cleaner  
Pembersih VAKUUM  
吸尘器

Drilling | Fastening  
Dredil | Pengetat  
钻孔 | 紧固

Impact Drilling | Demolition  
Gerudi | Penroboh  
起工钻孔 | 拆屋加工

Cutting  
Pemotong  
切割

Grinding | Sanding  
Pengisar | Pasir  
磨削 | 砂磨

Sawing  
Gergaji  
锯切

Planing | Routing  
Pengaram | Tangkap  
刨削 | 雕刻

Others  
Lain-lain  
其他

Outdoor Power Equipment  
Alatan Kerja Luar  
园机-户外



10.8V

Li-ion Ah 1.3

**TD091DWE**

RM 792

**Cordless Impact Driver**  
Pemutar Skru Impak Tanpa Kord  
充电式冲击螺丝起子机



- Battery power reduction warning lamp

• WE: 1x Standard Charger, 2x 1.3Ah Battery



440

<b>Capacity</b> Kapastiti 能力	Machine Screw: M4 - M8 (5/32" - 5/16") Standard Bolt: M5 - M12 (3/16" - 1/2") High Tensile Bolt: M5 - M10 (3/16" - 3/8") Coarse thread (in length): 22 - 90mm (7/8" - 3-1/2") 0 - 2,400
<b>No Load Speed (RPM)</b> Kelajuan Tanpa Beban 回转数	
<b>Impacts Per Minute (IPM)</b> Impak Per Minit 冲击数	0 - 3,000
<b>Max Fastening Torque</b> Maksimum Tenaga Pemutaran Pengancing 最快扭力	90N-m (800in.lbs.)
<b>Dimensions (L x W x H)</b> Dimensi 体积	134x54x200mm (5-1/4"x2-1/8"x7-7/8")
<b>Net Weight</b> Berat Bersih 净重	0.86kg (1.9lbs)
<b>Work Amount (approx.)</b> Jumlah Kerja 工作量	480 pcs with BL1013 Bolts M8x16mm

**TW100DWE**

RM 608

**Cordless Impact Wrench**  
Perengkuh Impak Tanpa Kord  
充电式冲击套筒扳手



- 9.5mm (3/8") square drive fits most common automotive sockets

• WE: 1x Standard Charger, 2x 1.3Ah Battery



<b>Fastening Capacities</b> Kapastiti 能力	Standard Bolt: M8 - M12 (5/16" - 1/2") High Tensile Bolt: M6 - M10 (1/4" - 3/8") 9.5mm (3/8")
<b>Square Drive</b> Batang Segi Empat 四方头	
<b>No Load Speed (RPM)</b> Kelajuan Tanpa Beban 回转数	0 - 2,300
<b>Impacts Per Minute (IPM)</b> Impak Per Minit 冲击数	0 - 3,000
<b>Max Fastening Torque</b> Maksimum Tenaga Pemutaran Pengancing 最快扭力	110N-m (1,000in.lbs.)
<b>Dimensions (L x W x H)</b> Dimensi 体积	163x54x178mm (6-3/8"x2-1/8"x7")
<b>Net Weight</b> Berat Bersih 净重	0.95kg (2.1lbs)
<b>Work Amount (approx.)</b> Jumlah Kerja 工作量	550 pcs with BL1013 Bolts M8x16mm

**CC300DW**

RM 987

**CC300DZ**

RM 710

**Cordless Cutter**  
Pemotong Tanpa Wayar  
充电式切割机



- Adjustable cutting depth up to 25.5mm at 90° and 16.5mm at 45°

Standard Equipment: Diamond Wheel, Water Supply Tank Assembly, Hex Wrench

- W: 1x Standard Charger, 1x 1.3Ah Battery
- Z: Without Charger, Battery & Carrying Case



<b>Blade Diameter</b> Diameter Bilah 锯片直径	85mm (3-3/8")
<b>Max Cutting Capacity</b> Kapastiti Pemotongan Maksimum 最大切割能力	90°: 25.5mm (1") 45°: 16.5mm (5/8")
<b>No Load Speed (RPM)</b> Kelajuan Tanpa Beban 回转数	1,400
<b>Tank capacity</b> Kapastiti Tangki 水箱容量	Water : 0.5L
<b>Dimensions (L x W x H)</b> Dimensi 体积	300x170x154mm (11-3/4"x6-11/16"x6-1/16")
<b>Net weight</b> Berat Bersih 净重	16kg (3.6lbs)
<b>Work Amount (approx.)</b> Jumlah Kerja 工作量	2.5 pcs with BL1013 Diamond Blade (Cut Glass 10x300mm)

**HS300DW**

RM 832

**Cordless Circular Saw**  
Gergaji Piring Tanpa Kord  
充电式圆锯



- Fast cutting of plywood, MDF, pegboard, particleboard, melamine, drywall and more

Standard Equipment: TCT Saw Blade (B-14607), Hex Wrench

- W: 1x Standard Charger, 1x 1.3Ah Battery



<b>Blade Diameter</b> Diameter Bilah 锯片直径	85mm (3-3/8")
<b>Max Cutting Capacity</b> Kapastiti Pemotongan Maksimum 最大切割能力	90°: 25.5mm (1") 45°: 16.5mm (5/8")
<b>No Load Speed (RPM)</b> Kelajuan Tanpa Beban 回转数	1,400
<b>Dimensions (L x W x H)</b> Dimensi 体积	300x170x154mm (11-3/4"x6-11/16"x6-1/16")
<b>Net Weight</b> Berat Bersih 净重	1.5kg (3.4lbs)
<b>Work Amount (approx.)</b> Jumlah Kerja 工作量	90 cuts with BL1013 Sawing SPF 1"x4" (0 Degree Cut)

**JV100DWE**

RM 865

**Cordless Jig Saw**  
Gergaji Jig Tanpa Kord  
充电式线锯机



- Aluminum die-cast base adjusts from 0°-45° right to left

Standard Equipment: Jig Saw Blade (B-10), Hex Wrench, Guide Rule

- WE: 1x Standard Charger, 2x 1.3Ah Battery



<b>Max Cutting Capacity at 90°</b> Kapastiti Pemotongan Maksimum 最大切割能力	Wood: 65mm (2-9/16") Aluminum: 4mm (5/32") Mild Steel: 2mm (1/16")
<b>Length of Stroke</b> Panjang Strok 冲程长度	18mm (11/16")
<b>Strokes Per Minute (SPM)</b> Kelajuan Strok 冲程速度	0 - 2,400
<b>Dimensions (L x W x H)</b> Dimensi 体积	231x76x196mm (9-1/8"x3"x7-3/4")
<b>Net Weight</b> Berat Bersih 净重	1.7kg (3.7lbs)
<b>Work Amount (approx.)</b> Jumlah Kerja 工作量	26 pcs with BL1013 Sawing (Fibreboard MDF 300x12mm)

\* All list price shown are for reference only (exclude SST).

\* Semua harga yang ditunjukkan adalah untuk rujukan sahaja (tidak termasuk SST). 所有显示的建议零售价仅供参考 (不包括SST)。

Cordless  
Target: Tools & Accessories

LED Flashlight  
Lampu Suli LED  
LED手电筒

Vacuum Cleaner  
Pembersih Vakuum  
吸尘器

Drilling / Fastening  
Gergaji / Pengikat  
钻孔 / 紧固

Impact Drilling / Demolition  
Gergaji / Pemusnah  
冲击钻孔 / 摧毁施工

Cutting  
Pemotong  
切割

Grinding / Sanding  
Pengkilan / Pemoles  
研磨 / 砂磨

Sawing  
Gergaji  
锯切

Planing / Routing  
Pengkilan / Tumpang  
刨削 / 压花

Others  
Lain-lain  
其他

Outdoor Power Equipment  
Alatan Kerja Luar  
园机 / 户外

Makita  
1915

10.8V

7.2V

Li-ion Ah 1.5 1.3 1.0

Cordless Target Kord 无绳式  
LED Flashlight Lampu Suluhi LED LED 照明灯  
Vacuum Cleaner Pembersih Vakuüm 吸尘器  
Drilling / Fastening Dremel / Pengikat 钻式 / 紧固  
Impact Drilling / Demolition Ganda / Penembok 起工钻式 / 拆墙加工  
Cutting Pemotong 切割  
Grinding / Sanding Pengisar / Piskin 磨削 / 砂磨  
Sawing Gergaji 电锯  
Planing / Routing Pengisar / Tampang 刨削 / 雕刻  
Others Lain-lain 其他  
Outdoor Power Equipment Alatan Kerja Luar 园林-户外

**JR100DWE**

RM 920

**Cordless Recipro Saw**

Gergaji Resipro Tanpa Kord  
充电式往复锯



- Dual-position on/off switch design allows for either paddle or trigger switch operation



Standard Equipment: Recipro Saw Blades 2pcs (B-20404 & B-20432)

- WE: 1x Standard Charger, 2x 1.3Ah Battery



<b>Capacity</b> Kapasiti 能力	Pipe : 50mm (2") Wood: 50mm (2")
<b>Length of Stroke</b> Panjang Strok 冲程长度	13mm (1/2")
<b>Strokes Per Minute (SPM)</b> Kelajuan Strok 冲程速度	0-3,300
<b>Dimensions (L x W x H)</b> Dimensi 体积	355x63x146mm (14"x2-1/2"x5-3/4")
<b>Net Weight</b> Berat Bersih 淨重	1.2kg (2.6lbs)
<b>Work Amount (approx.)</b> Jumlah Kerja 工作量	55 pcs with BL1013 Cutting (PVC Plastic Hose 48mm)

**JR102DWE**

RM 885

**Cordless Recipro Saw**

Gergaji Resipro Tanpa Kord  
充电式往复锯



- Accepts both Recipro and Jig saw blades



Standard Equipment: Hex Wrench,  
Recipro Saw Blades 2pcs (B-20404 & B-20432)

- WE: 1x Standard Charger, 2x 1.3Ah Battery



<b>Capacity</b> Kapasiti 能力	Pipe : 50mm (2") Wood: 50mm (2")
<b>Length of Stroke</b> Panjang Strok 冲程长度	13mm (1/2")
<b>Strokes Per Minute (SPM)</b> Kelajuan Strok 冲程速度	0-3,300
<b>Dimensions (L x W x H)</b> Dimensi 体积	355x63x146mm (14"x2-1/2"x5-3/4")
<b>Net Weight</b> Berat Bersih 淨重	1.2kg (2.6lbs)
<b>Work Amount (approx.)</b> Jumlah Kerja 工作量	55 pcs with BL1013 Cutting (PVC Plastic Hose 48mm)

**TD022DSE**

RM 933

**Cordless Impact Driver**

Pemutar Skru Impak Tanpa Kord  
充电式冲击螺丝起子机

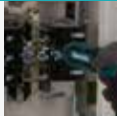

- Compact and lightweight design



Standard Equipment: Holster, Phillips Bit

- SE: 1x Standard Charger, 2x 1.5Ah Battery



<b>Capacity</b> Kapasiti 能力	Machine Screw: M3 - M8 (1/8" - 5/16") Standard Bolt: M3 - M8 (1/8" - 5/16") High Tensile Bolt: M3 - M6 (1/8" - 1/4") Coarse thread (in length): 22 - 45mm (7/8" - 1-3/4") 6.35mm (1/4")
<b>Hex Shank</b> Batang Heksagon 六角柄	
<b>No Load Speed (RPM)</b> Kelajuan Tanpa Beban 回转速数	0 - 2,450
<b>Impacts Per Minute (IPM)</b> Impak Per Minit 冲击数	0 - 3,000
<b>Max Fastening Torque</b> Maksimum Tenaga Pemutaran Pengancing 最快扭力	25N-m (220in.lbs.)
<b>Dimensions (L x W x H)</b> Dimensi 体积	Straight Style: 282x42x52mm (11-1/8"x1-5/8"x2-1/16") Pistol Style: 227x42x142mm (8-15/16"x1-5/8"x5-5/8")
<b>Net Weight</b> Berat Bersih 淨重	0.55 - 0.56kg (1.2lbs)
<b>Work Amount (approx.)</b> Jumlah Kerja 工作量	320 pcs with BL7010 Wood Screw ø3.1x25mm (Melapi Drove Wood)

**TD020DSW**

RM 710

**Cordless Impact Driver**

Pemutar Skru Impak Tanpa Kord  
充电式冲击螺丝起子机



- Compact and lightweight design



Standard Equipment: Holster, Bit set

- SW: 1x Standard Charger, 1x 1.0Ah Battery (White)



<b>Capacity</b> Kapasiti 能力	Machine Screw: M3 - M8 (1/8" - 5/16") Standard Bolt: M3 - M8 (1/8" - 5/16") High Tensile Bolt: M3 - M6 (1/8" - 1/4") Coarse thread (in length): 22 - 45mm (7/8" - 1-3/4") 6.35mm (1/4")
<b>Hex Shank</b> Batang Heksagon 六角柄	
<b>No Load Speed (RPM)</b> Kelajuan Tanpa Beban 回转速数	2,300
<b>Impacts Per Minute (IPM)</b> Impak Per Minit 冲击数	3,000
<b>Max Fastening Torque</b> Maksimum Tenaga Pemutaran Pengancing 最快扭力	20N-m (177in.lbs.)
<b>Dimensions (L x W)</b> Dimensi 体积	Straight Style: 276x40mm (10-7/8"x1-9/16")
<b>Dimensions (L x W x H)</b> Dimensi 体积	Pistol Style: 213x40x131mm (8-3/8"x1-9/16"x5-1/8")
<b>Net Weight</b> Berat Bersih 淨重	0.53 - 0.54kg (1.2lbs)
<b>Work Amount (approx.)</b> Jumlah Kerja 工作量	232 pcs with BL7010 Wood screw ø3.1x25mm (Melapi White Wood)

**DF012DSE**

RM 885

**Cordless Driver Drill**

Gerudi Pemutar Skru Tanpa Kord  
充电式螺丝起子电钻



- 2-Speed design for high or low torque applications



Standard Equipment: Phillips Bit 2pcs

- SE: 1x Standard Charger, 2x 1.5Ah Battery



<b>Capacity</b> Kapasiti 能力	Steel: 5mm (3/16") Wood: 6mm (1/4")
<b>No Load Speed (RPM)</b> Kelajuan Tanpa Beban 回转速数	High: 650 Low: 200
<b>Max Fastening Torque</b> Maksimum Tenaga Pemutaran Pengancing 最快扭力	Hard: 5.6N-m (50in.lbs.) Soft: 3.6N-m (32in.lbs.)
<b>Max Lock Torque</b> Pemutaran Tenaga Maksimum 最大扭力	8.0N-m (71in.lbs.)
<b>Dimensions (L x W x H)</b> Dimensi 体积	Pistol Style: 218x44x142mm (8-5/8"x1-3/4"x5-5/8")
<b>Dimensions (L x W)</b> Dimensi 体积	Straight Style: 273x44mm (10-3/4"x1-3/4")
<b>Net Weight</b> Berat Bersih 淨重	0.53kg (1.2lbs.)
<b>Work Amount (approx.)</b> Jumlah Kerja 工作量	350 pcs with BL7010 Wood screw ø3.8x25mm (Melapi Drove Wood)

\* All list price shown are for reference only (exclude SST).

\* Semua harga yang ditunjukkan adalah untuk rujukan sahaja (tidak termasuk SST). 所有显示的建议零售价仅供参考 (不包括SST)。



3.6V

Li-ion Ah 1.5



# DF001DW Li-ion 3.6V In-Line Cordless Screwdriver

Pemutar Skru Tanpa Kord Yang Tahan Lasak 充电式螺丝起子机

Comes with 81pcs assortment and Charger

Termasuk 81 bit dan pengecas | 81支配件与充电器套装

### Drive type

Phillips (PH)	PZ	Hex (H)
T	Slotted (SL)	

### C-form 25mm Screw bit

PZ : 0, 1, 2, 3 (3pc each)  
 Hex : 2, 2.5, 3, 4, 5, 6 (2pc each)  
 T : 10, 15, 20, 25, 27, 30, 40 (3pc each)  
 SL : 0.5x3, 0.5x4, 0.6x4.5, 0.8x5.5, 1.0x5.5, 1.2x6.5 (2pc each)  
 PH : 0, 1, 2 (3pc each), 3 (2pc each)

### E-form 50mm Screw bit

T : 20, 25, 30 (1pc each)  
 PH : 1, 2, 3 (1pc each)

### E-form Socket Wrench

5, 6, 7, 8, 9, 10mm (1pc each)

### E-form magnetic bit holder

60mm (1pc each)



**Straight style**  
 Dalam keadaan melurus  
 直式

**Can be used as both of straight style and pistol style**  
 Boleh digunakan dalam keadaan melurus atau pistol/ 可以用作直式和手枪式两种方式

**Pistol style**  
 Dalam keadaan pistol  
 手枪式



## DF001DW

RM 353

### In-Line Cordless Screwdriver

Pemutar Skru Tanpa Kord  
 充电式螺丝起子机



3.6V



- Convenient to used even in narrow space

Standard Equipment: Bit Set 81pcs, AC Adaptor, USB Cable



### Fastening Capacities

Kapasiti Pengancing 最大紧固能力

Wood Screw: ø3.8 x 32mm  
 (1/8"x1-1/4")

### No Load Speed (RPM)

Kelajuan Tanpa Beban 无负荷转速

220

### Max Fastening Torque

Maksimum Tenaga Pemutaran Pengancing 最大扭矩

Hard: 4.0N·m (35in.lbs.)

Soft: 3.0N·m (27in.lbs.)

### Max Lock Torque

Maksimum Pengunci Tenaga Pemutaran 最大扭矩

6.0N·m (53 in.lbs.)

### Charging Time (hours)

Masa Pengecasan 充电时间

3 - 5

### Dimensions (L x W x H)

Dimensi 体积

Straight Style: 287x47x51mm

(11-1/4"x1-7/8"x2")

Pistol Style: 205x47x51mm

(8-1/8"x1-7/8"x2")

0.36kg (0.8 lbs.)

### Net Weight

Keberatan 净重

### Work Amount (approx.)

Jumlah Kerja 工作量

200 pcs

Wood Screw ø3.8x25mm (SPF plate)

Cordless  
 Tanpa Kord

LED Flashlight  
 Lampu Suhu LED  
 LED 照明灯

Vacuum Cleaner  
 Pembunuh Vakuum  
 吸尘器

Drilling / Fastening  
 Ganda / Pengikat  
 钻孔 / 紧固

Impact Drilling / Demolition  
 Ganda / Pemusnah  
 冲击钻孔 / 摧毁施工

Cutting  
 Pemotong  
 切割

Grinding / Sanding  
 Pengisar / Pechin  
 研磨 / 砂磨

Sanding  
 Ganda  
 磨光

Planing / Routing  
 Pengaliran / Tergambar  
 刨削 / 雕刻

Others  
 Lain-lain  
 其他

Outdoor Power Equipment  
 Alatan Kerja Luar  
 园机 / 户外



\* All list price shown are for reference only (exclude SST).

\* Semua harga yang ditunjukkan adalah untuk rujukan sahaja (tidak termasuk SST). 所有显示的建议零售价仅供参考 (不包括SST)。

36V

Li-ion Ah 12 | 2.6 | 2.2

Cordless  
Tanpa Kord Tanpa Kord

LED Flashlight  
Lampu Sulu LED  
LED 照灯

Vacuum Cleaner  
Pembersih Vakuum  
吸尘器

Drilling / Fastening  
Drauli / Pengikat  
钻孔 / 紧固

Impact Drilling / Demolition  
Gardu / Persekolah  
石工钻孔 / 拆墙加工

Cutting  
Pemotong  
切割

Grinding / Sanding  
Pengisar / Poles  
磨削 / 打磨

Sawing  
Gergaji  
锯切

Planing / Routing  
Pengisar / Tangkai  
刨削 / 雕刻

Others  
Lain-lain  
其他

Outdoor Power Equipment  
Alatan Kerja Luar  
园林-户外

Makita  
19157



**BHR262RB3** 26mm (1")  
RM 2,697

442

**Cordless Combination Hammer**  
Tukul Kombinasi Tanpa Kord  
充电式冲击钻锤



- 3-Mode operation for Rotation Only, Hammering with Rotation or Hammering Only

Sementara stok masih ada 售完即止  
**WHILE STOCK LAST**



Standard Equipment: Depth Gauge, Side Grip, Bit Grease (194683-7), Cleaning Cloth, Tool Bag

- RB3: 1x 18V Rapid Charger, 3x 18V 3.0Ah Battery, 1x Battery Converter (BCV03)



<b>Impact Energy</b> Kekuatan Impak 单次最大冲击力	2.5J
<b>Capacity</b> Kapasiti 能力	Concrete: 26mm (1")   Steel: 13mm (1/2")   Wood: 32mm (1-1/4")
<b>Impacts Per Minute (IPM)</b> Impak Per Minit 冲击数	0 - 4,800
<b>No Load Speed (RPM)</b> Kelajuan Tanpa Beban 回转数	0 - 1,200
<b>Dimensions (L x W x H)</b> Dimensi 体积	363x104x235 mm (14-1/4"x4-1/8"x9-1/4")
<b>Net Weight</b> Berat Bersih 净重	4.6 - 5.1kg (10.2 - 11.2lbs.)

**BUC250RD** 250mm (10")  
RM 3,822

442

**Cordless Chain Saw**  
Gergaji Rantai Tanpa Kord  
充电式链锯



- Low noise level and zero emissions for operator comfort



Sementara stok masih ada 售完即止  
**WHILE STOCK LAST**

Standard Equipment: Guide Bar, Guide Bar Cover, Saw Chain, Chain Oil, Chain File (744003-1)

- RD: 1x 36V Rapid Charger (DC36RA), 1x 36V 2.6Ah Battery (BL3626)



<b>Guide Bar Length</b> Panjang Batang Gergaji 切割长度	250mm (10")
<b>Chain Pitch</b> Kerapatan Rantai 链条齿距	3/8" or 1/4"
<b>Chain Oil Tank Volume</b> Tangki Minyak Pelincir 链油箱	85mL (2.9US oz)
<b>Dimensions (L x W x H)</b> Dimensi 体积	576x239x200mm (22-3/4"x9-3/8"x7-7/8")
<b>Net Weight</b> Keberatan 净重	4.5kg (9.9lbs.)

**BUH550RD** | **BUH550Z** | **UH550DWB** 550mm (21-5/8")  
RM 3,370 | RM 1,557 | RM 3,113

442

**Cordless Hedge Trimmer**  
Pemangkas Tanaman Pagar  
Tanpa Kord  
充电式篱笆修剪机



- 5-Position rotating rear handle for increased comfort during vertical and angle trimming



Sementara stok masih ada 售完即止  
**WHILE STOCK LAST**

Standard Equipment: Blade Cover

- RD: 1x 36V Rapid Charger (DC36RA), 1x 36V 2.6Ah Battery (BL3626)
- DWB: 1x 36V Standard Charger (DC36WA), 1x 36V 2.2Ah Battery (BL3622A)
- Z: Without Charger & Battery



<b>Blade Length</b> Panjang bilah 刀片长度	550mm (21-5/8")
<b>Strokes Per Minute (SPM)</b> Kelajuan Strok 冲程速度	2,000 - 3,600
<b>Tooth Spacing</b> Selang Gigi 牙齿间隔	36mm (1-7/16")
<b>Dimensions (L x W x H)</b> Dimensi 体积	1,070x220x190mm (42"x8-5/8"x7-1/2")
<b>Net Weight</b> Keberatan 净重	5.1kg (11.2lbs.)

\* All list price shown are for reference only (exclude SST).

\* Semua harga yang ditunjukkan adalah untuk rujukan sahaja (tidak termasuk SST). 所有显示的建议零售价仅供参考 (不包括SST)。



Li-ion Ah 12 2.6 2.2

**BUH650RD** | **BUH650Z** | **UH650DWB** 650mm (25-1/2") 442 (RM)

**Cordless Hedge Trimmer**  
Pemangkas Tanaman Pagar Tanpa Kord  
充电式篱笆修剪机



- 5-Position rotating rear handle for increased comfort during vertical and angle trimming

Standard Equipment: Blade Cover

- RD: 1x 36V Rapid Charger (DC36RA), 1x 36V 2.6Ah Battery (BL3626)
- DWB: 1x 36V Standard Charger (DC36WA), 1x 36V 2.2Ah Battery (BL3622A)
- Z: Without Charger & Battery



<b>Blade Length</b> Panjang bilah 刀片长度	650mm (25-1/2")
<b>Strokes Per Minute (SPM)</b> Kelajuan Strok 冲程速度	2,000 - 3,600
<b>Tooth Spacing</b> Selang Gigi 牙齿间隔	36mm (1-7/16")
<b>Dimensions (L x W x H)</b> Dimensi 体积	1,150x220x190mm (45-1/4"x8-5/8"x7-1/2")
<b>Net Weight</b> Keberatan 净重	5.2kg (11.5lbs.)

**BUN490RD** RM 5,998

**Cordless Pole Hedge Trimmer**  
Pemangkas Tanaman Pagar Tinggi Tanpa Kord  
充电式高枝篱笆修剪机



- Can be folded in the 180° position for easy transport and storage

Standard Equipment: Band Assembly, Wrench, Accessory Bag

- RD: 1x 36V Rapid Charger (DC36RA), 1x 36V 2.6Ah Battery (BL3626)



<b>Strokes Per Minute (SPM)</b> Kelajuan Strok 冲程速度	High: 0 - 4,000   Low: 0 - 2,800
<b>Tooth Spacing</b> Selang Gigi 牙齿间隔	35mm (1-3/8")
<b>Dimensions (L x W x H)</b> Dimensi 体积	2,595x226x211mm (100-3/16"x8-7/8"x8-5/16")
<b>Net Weight</b> Keberatan 净重	6.9kg (15.2 - 15.3lbs.)

**BBC231URDE** | **BBC231UZ** | **BC231UDWBE** RM 8,812 | RM 3,542 | RM 8,553

**Cordless Brushcutter**  
Pemotong Rumput Tanpa Kord  
充电式割草机



- Low noise level and zero emissions for operator comfort

Standard Equipment: Blade, Guard, Shoulder Harness with Double Shoulder Strap, Wrenches

- RDE: 1x 36V Rapid Charger (DC36RA), 2x 36V 2.6Ah Battery (BL3626)
- WBE: 1x 36V Standard Charger (DC36WA), 2x 36V 2.2Ah Battery (BL3622A)
- Z: Without Charger & Battery



<b>No Load Speed (RPM)</b> Kelajuan Tanpa Beban 回转数	High: 0-7,300   Low: 0-5,300
<b>Spindle Size</b> Saiz Spindel 主轴尺寸	M10 x 1.25LH
<b>Dimensions (L x W x H)</b> Dimensi 体积	1,880x620x490mm (74"x24-3/8"x19-1/4")
<b>Net Weight</b> Keberatan 净重	7.1kg (15.7lbs.)

**BBC300LRDE** RM 8,297

**Cordless String Trimmer**  
Pemotong Rumput Tanpa Kord  
充电式割草机



- Low noise level and zero emissions for operator comfort

Standard Equipment: Nylon Cutting Head, Guard, Band Assembly, Wrenches, Accessory Bag

- RDE: 1x 36V Rapid Charger (DC36RA), 2x 36V 2.6Ah Battery (BL3626)



<b>No Load Speed (RPM)</b> Kelajuan Tanpa Beban 回转数	High: 0 - 6,600   Low: 0 - 4,900
<b>Spindle Size</b> Saiz Spindel 主轴尺寸	M10 x 1.25LH
<b>Dimensions (L x W x H)</b> Dimensi 体积	1,850x340x325mm (73"x13-3/8"x12-3/4")
<b>Net Weight</b> Keberatan 净重	5.9kg (13lbs.)

**BML360Z** (STEXBML360) RM 399.10

**Cordless Fluorescent Light**  
Lampu Suluh Tanpa Kord  
充电式工作灯



- Wide and bright illumination

- Z: Without Charger & Battery



<b>Dimensions (L x W x H)</b> Dimensi 体积	283x128x203mm (11-1/8"x5"x8")
<b>Net Weight</b> Berat Bersih 净重	2.3kg (5.1lbs.)

\* All list price shown are for reference only (exclude SST).

\* Semua harga yang ditunjukkan adalah untuk rujukan sahaja (tidak termasuk SST). 所有显示的建议零售价仅供参考 (不包括SST)。

**Cordless**  
Tanpa Kord / Tanpa Kabel

**LED Flashlight**  
Lampu Suluh LED  
LED工作灯

**Vacuum Cleaner**  
Pembersih Vakuum  
吸尘器

**Drilling / Fastening**  
Gergaji / Pengikat  
钻孔 / 紧固

**Impact Drilling / Demolition**  
Gergaji / Pemusnah  
冲击钻孔 / 拆除施工

**Cutting**  
Pemotong  
切割

**Grinding / Sanding**  
Pengisar / Poles  
打磨 / 砂磨

**Sawing**  
Gergaji  
锯切

**Planing / Routing**  
Pengukir / Tunggam  
刨削 / 雕刻

**Others**  
Lain-lain  
其他

**Outdoor Power Equipment**  
Alatan Kuat Luar  
户外动力工具

**Thakita**  
TENT

14.4V

12V

9.6V



**DTL062Z** 9.5mm (3/8")  
RM 1,218

**Cordless Angle Impact Wrench**  
Perengkuh Impak Sudut Tanpa Kord  
充电式角向冲击套筒扳手



14.4V



Standard Equipment: Belt Clip

• Z: Without Charger & Battery



**Fastening Capacities**  
Kapasiti 能力

**Standard Bolt:**  
M4 - M12 (5/32" - 1/2")  
**High Strength Bolt:**  
M4 - M8 (5/32" - 5/16")  
9.5mm (3/8")

**Square Drive**  
Skrü Persegi 方形螺柱

**No Load Speed (RPM)**  
Kelajuan Tanpa Beban 回转速

0 - 2,000

**Impacts Per Minute (IPM)**  
Impak Per Minit 冲击数

0 - 3,000

**Max Fastening Torque**  
Pemutaran Tenaga Maksimum 最大扭矩

60N-m

**Dimensions (L x W x H)**  
Dimensi 体积

387x78x97mm  
(15-1/4"x3-1/16"x3-13/16")

**Net Weight**  
Berat Bersih 淨重

1.4 - 1.8kg (3.0 - 4.1lbs.)

**DTW152Z** 12.7mm (1/2")  
RM 1,205

440

**Cordless Impact Wrench**  
Perengkuh Impak Tanpa Kord  
充电式冲击套筒扳手



14.4V



• Compact and lightweight 4-pole motor

Standard Equipment: Belt Clip

• Z: Without Charger & Battery



**Fastening Capacities**  
Kapasiti 能力

**Standard Bolt:**  
M8 - M16 (5/16" - 5/8")  
**High Strength Bolt:**  
M8 - M12 (5/16" - 1/2")  
12.7 mm (1/2")

**Square Drive**  
Skrü Persegi 方形螺柱

**No Load Speed (RPM)**  
Kelajuan Tanpa Beban 回转速

0 - 2,400

**Impacts Per Minute (IPM)**  
Impak Per Minit 冲击数

0 - 3,200

**Max Fastening Torque**  
Pemutaran Tenaga Maksimum 最大扭矩

200N-m (150ft.lbs.)

**Dimensions (L x W x H)**  
Dimensi 体积

158x79x234mm  
(6-1/4"x3-1/8"x9-1/4")

**Net Weight**  
Berat Bersih 淨重

1.3 - 1.5kg (2.8 - 3.4lbs.)

**6271DWE** 10mm (3/8")  
RM 745

**Cordless Driver Drill**  
Gerudi Pemutar Skrü Tanpa Kord  
充电式螺丝起子电钻



12V

Ni-Cd Battery



• All metal gear construction ensures high transmission durability

Standard Equipment: (+)(-) Bit

• WE: 1x Standard Charger, 2x 1.3Ah Ni-Cd Battery



**Capacity**  
Kapasiti 能力

**Steel:** 10mm (3/8")  
**Wood:** 21mm (13/16")

**No Load Speed (RPM)**  
Kelajuan Tanpa Beban 回转速

**High:** 0-1,300

**Low:** 0-400

**Max Fastening Torque**  
Maksimum Tenaga Pemutaran Pengancing 最快扭力

**Hard:** 30N-m/ **Soft:** 18N-m

**Dimensions (L x W x H)**  
Dimensi 体积

192x95x240mm

**Net Weight**  
Berat Bersih 淨重

(7-9/16"x3-3/4"x9-1/2")  
1.5kg (3.4lbs.)

**4190DW** 80mm (3-1/8")  
RM 1,765

**Cordless Cutter**  
Pemotong Tanpa Wayar  
充电式切割机



9.6V

Ni-Cd Battery



• Fast and easy glass and ceramic tile cutting

Standard Equipment: Diamond Wheel (792296-4), Hex Wrench

• W: 1x Standard Charger, 1x 1.3Ah Ni-Cd Battery

**Blade Diameter**  
Diameter Bilah 锯片直径

80mm (3-1/8")

**Max Cutting Capacity**  
Kapasiti Pemotongan Maksimum 最大切割能力

90°: 18mm (11/16")

45°: 16mm (5/8")

**No Load Speed (RPM)**  
Kelajuan Tanpa Beban 回转速

1,000

**Overall Length**  
Dimensi 体积

313mm (12-3/8")

**Net Weight**  
Berat Bersih 淨重

1.9kg (4.2lbs.)

\* All list price shown are for reference only (exclude SST).

\* Semua harga yang ditunjukkan adalah untuk rujukan sahaja (tidak termasuk SST). 所有显示的建议零售价仅供参考 (不包括SST)。







# Cordless Coffee Maker

Mesin Kopi Tanpa Kord 充电式咖啡机



# Job Site Radio

Radio Tanpa Kord 充电式收音机



# Cordless Fan

Kipas Tanpa Kord 充电式风扇



Cordless  
Tanpa Kord 充电式

LED Flashlight  
Lampu Saku LED  
LED 手电筒

Vacuum Cleaner  
Pembersih Vakuum  
吸尘器

Drilling / Fastening  
Gardu / Pengikat  
钻头 / 紧固件

Impact Drilling / Demolition  
Gardu / Perusak  
冲击钻头 / 拆墙工具

Cutting  
Pemotong  
切割机

Grinding / Sanding  
Pengkil / Pasir  
打磨 / 砂磨

Sawing  
Gergaji  
锯切

Planing / Routing  
Pengkilan / Tergambar  
刨削 / 雕刻

Others  
Lain-lain  
其他

Outdoor Power Equipment  
Alat-alat Kelistrikan  
户外电力设备





## 7 Selectable Sound Modes

7 Mod bunyi yang boleh dipilih 7种可选声音模式

Equalizer	LED		
FLAT	White	CLASSIC	Brown
		POP	Pink
JAZZ	Blue	NEWS	Yellow
		MY EQ	Green
ROCK	Red		



**Carry handle with built in FM antenna**

Carry handle dengan terbita dalam antenna FM  
内置手柄调频天线



**USB output port allows for charging a mobile device**

• Type A USB socket for DC5V / 2.4A USB output

**AUX-IN jack**

Jack AUX-IN AUX-IN插孔

### DMR114 18V / 12Vmax / AC Price TBA

**Job Site Radio**  
Radio Tanpa Kord  
充电式收音机



• Equipped with equalizer for 7 selectable sound modes

Standard Equipment: AC Adaptor

• Without Charger & Battery



<b>Frequency Band</b> Julat Kekerapan 频率范围	FM: 87.5 - 108MHz AM: 522 - 1,710kHz
<b>Speaker Size</b> Saiz Speaker 喇叭尺寸	Sides: Ø63.5mm x2 Bottom: Ø101.6mm
<b>Bluetooth</b> Bluetooth 蓝牙连接	Version: 5.0 Profile: A2DP   SCMS-T   AVRCP Supported Codec: SBC / AAC Max Transmission Range: (Optimum): 10m (33ft)   (Possible): 30m (98ft) Transmission Power Class: 2 Compatible Bluetooth Profile: A2DP

<b>Dimensions (L x W x H)</b> Dimensi 体积	268x164x295mm (10-1/2"x6-1/2"x11-5/8")
<b>Net Weight</b> Berat Bersih 净重	4.9 - 5.6kg (10.8 - 12.3lbs.)
<b>Continuous Usage Time (approx.)</b> Masa Penggunaan Berterusan 连续使用时间	17 hrs with BL1850B

### DMR203 18V / 12Vmax / AC Price TBA

**Cordless Job Site Speaker**  
Pembesar Suara Tanpa Kord  
充电式音箱



• Equipped with equalizer for 7 selectable sound modes

Standard Equipment: AC Adaptor

• Without Charger & Battery



<b>Speaker Size</b> Saiz Speaker 喇叭尺寸	Sides: Ø63.5mm x2 Bottom: Ø101.6mm
<b>Bluetooth</b> Bluetooth 蓝牙连接	Version: 5.0 Profile: A2DP   SCMS-T   AVRCP Supported Codec: SBC Max Transmission Range: 10m (33ft) Max Transmission Range (Possible): 30m (100ft)

<b>Dimensions (L x W x H)</b> Dimensi 体积	217x206x199mm (8-1/2"x8-1/8"x7-7/8")
<b>Net Weight</b> Berat Bersih 净重	2.7 - 3.4kg (6.0 - 7.5lbs.)
<b>Continuous Usage Time (approx.)</b> Masa Penggunaan Berterusan 连续使用时间	29 hrs with BL1850B

## Product Comparison List 18V 12Vmax

Senarai Perbandingan Produk 产品对比表

Run time (hrs)	Up to: 17 with BL1850B	DMR114	Up to: 26 Bluetooth: with BL1850B	DMR203
	●		●	
Net weight	5.1 - 5.6kg (11.3 - 12.3lbs.)		2.7 - 3.4kg (6.0 - 7.5lbs)	

\* All list price shown are for reference only (exclude SST).

\* Semua harga yang ditunjukkan adalah untuk rujukan sahaja (tidak termasuk SST). 所有显示的建议零售价仅供参考 (不包括SST)。

Cordless Target Kord 无绳式  
LED Flashlight Lampu Suluh LED LED手电筒  
Vacuum Cleaner Pemilauhi VAKUM 吸尘器  
Drilling / Fastening Daurul / Pengikat 钻工 / 螺丝  
Impact Drilling / Demolition Daurul / Penembak 钻工 / 拆墙  
Cutting Pemotong 切割机  
Grinding / Sanding Pengisar / Piskin 磨削 / 砂磨  
Sawing Gergaji 电锯  
Planing / Routing Pengisar / Tangkap 刨削 / 雕刻  
Others Lain-lain 其他  
Outdoor Power Equipment Alatan Kerja Luar 园具-户外  
Makita

18V

LXT

Li-ion Ah 6.0 | 5.0 | 4.0 | 3.0 | 2.0 | 1.5

# Cordless Fan

Kipas Tanpa Kord 充电式风扇

Max Air Speed  
Kelajuan angin maksimum  
最大风速  
**190m/min**

\*Masa Penggunaan Berterusan  
连续使用时间  
**Continuous Usage Time**  
with BL1850B x1  
(High Speed)  
**360min**  
(approx.)

\* Continuous Usage Time/ Work Amount:  
Actual performance may vary based on application.  
Masa Penggunaan Berterusan/ Jumlah Kerja: Prestasi sebenar  
mungkin berbeza mengikut aplikasi.  
连续使用时间/ 工作量: 实际表现可能因应用而异。



Adjustable fan head angle

Sudut kepala kipas boleh laras 可调整风扇头角度



Up 90°, Down 45°  
Left/ Right 90°

Automatic swing fan

Left/ Right 45°  
Kipas pusing automatik Kiri / Kanan 45°  
自动摇摆左/右45°

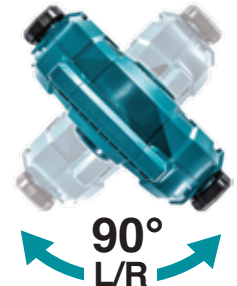

**DCF203Z** 18V / 14.4V  
RM 1,290

**Cordless Fan**  
Kipas Tanpa Kord  
充电式风扇



• Cordless automatic swing fan



• Z : Without Charger & Battery



<b>Max Air Velocity</b> Kelajuan Angin Maksimum 最大风速	High: 190m/min   Med: 150m/min   Low: 120m/min
<b>Air Flow</b> Aliran Udara 空气流量	High: 8.2m³/min   Med: 6.5m³/min   Low: 5.2m³/min
<b>Dimensions (L x W x H)</b> Dimensi 体积	140x333x447mm (5-1/2"x13"x16-1/2")
<b>Net Weight</b> Berat Bersih 净重	1.9 - 2.6kg (4.2 - 5.6lbs.)
<b>Continuous Usage Time (approx.)</b> Masa Penggunaan Berterusan 连续使用时间	Low: 1,010 min   Med: 650 min   High: 410 min with BL1860B

**DCF102Z** 18V / 14.4V  
RM 678

**Cordless Fan**  
Kipas Tanpa Kord  
充电式风扇



• Automatically Swings 45° L/R

• Z : Without Charger & Battery



<b>Air Flow</b> Aliran Udara 空气流量	High: 4.6L/min   Med: 3.8L/min   Low: 3.0L/min
<b>Dimensions (L x W x H)</b> Dimensi 体积	185x272x284mm (7-1/4"x10-3/10"x11-1/8")
<b>Net Weight</b> Berat Bersih 净重	1.3 - 2.0kg (2.9 - 4.4lbs.)
<b>Continuous Usage Time (approx.)</b> Masa Penggunaan Berterusan 连续使用时间	Low: 1,270 min   Mid: 705 min   High: 575 min with BL1860B

**DCF201Z** 18V  
RM 545

**Cordless Fan**  
Kipas Tanpa Kord  
充电式风扇



• Strong enough to create a comfortable work environment under hot weather

• Z : Without Charger & Battery



<b>Dimensions (L x W x H)</b> Dimensi 体积	263x330x523mm (10-3/8"x13"x20-5/8")
<b>Net Weight</b> Berat Bersih 净重	2.5 - 2.9kg (5.5 - 6.3lbs.)
<b>Continuous Usage Time (approx.)</b> Masa Penggunaan Berterusan 连续使用时间	Low: 330min   High: 165min with BL1850B

\* All list price shown are for reference only (exclude SST).

\* Semua harga yang ditunjukkan adalah untuk rujukan sahaja (tidak termasuk SST). 所有显示的建议零售价仅供参考 (不包括SST)。

Cordless  
Target: Kipas Tanpa Kord

LED Flashlight  
Lampu Suluh LED  
LED手电筒

Vacuum Cleaner  
Pembersih Vakuum  
吸尘器

Drilling / Fastening  
Ganda / Pengikat  
钻孔 / 紧固

Impact Drilling / Demolition  
Ganda / Penebuk  
冲击钻孔 / 拆墙工具

Cutting  
Pemotong  
切割

Grinding / Sanding  
Pengisar / Pech  
研磨 / 砂磨

Sawing  
Ganda  
锯切

Planing / Routing  
Pengaliran / Tangkapan  
刨削 / 雕刻

Others  
Lain-lain  
其他

Outdoor Power Equipment  
Alatan Kuat Luar  
园机/户外

Makita  
19157



**CF101DZ** 12Vmax  
RM 643

**Cordless Fan**  
Kipas Tanpa Kord  
充电式风扇



- Automatically Swings 45° L/R

- Z: Without Charger & Battery



<b>Air Flow</b> Aliran Udara 空气流量	High: 4.6L/min   Med: 3.8L/min   Low: 3.0L/min
<b>Dimensions (L x W x H)</b> Dimensi 体积	185x260x284mm (7-1/4"x10-1/4"x11-1/8")
<b>Net Weight</b> Berat Bersih 净重	1.3 - 1.7kg (2.8 - 3.8lbs.)
<b>Continuous Usage Time (approx.)</b> Masa Penggunaan Berterusan 连续使用时间	Low - 315min   Med - 190min   High - 135min with BL1021B

**CF100DZ** 12Vmax / AC  
RM 487

**Cordless Fan**  
Kipas Tanpa Kord  
充电式风扇



- Compact Size Allows Installation Even in Small Spaces

Standard Equipment: AC Adaptor

- Z: Without Charger & Battery



<b>Dimensions (L x W x H)</b> Dimensi 体积	148x260x252mm (5-7/8"x10-1/4"x9-7/8")
<b>Net Weight</b> Berat Bersih 净重	1.2 - 1.4kg (2.7 - 3.1lbs)
<b>Continuous Usage Time (approx.)</b> Masa Penggunaan Berterusan 连续使用时间	Low - 315min   Med - 190min   High - 135min with BL1021B

**Product Comparison List** 18V 12Vmax

Senarai Perbandingan Produk 产品对比表

	DCF203	DCF102	DCF201	CF101D	CF100D
<b>Run time (min.)</b>	High: 360   Med: 580   Low: 960 with BL1850B	High: 480   Med: 585   Low: 1060 with BL1850B	High: 180   Low: 400 with BL1850B	High: 630   Med: 380   Low: 275 with BL1041B	High: 275   Med: 380   Low: 630 with BL1041B
<b>Max air speed (m/ min)</b>	190	180	120	180	180
<b>Fan size (mm)</b>	235	180	230	180	180
<b>Automatic swing fan</b>	●	●	●	●	●
<b>Net weight</b>	1.9 - 2.6 kg (4.2 - 5.6 lbs.)	1.3 - 2.0 kg (2.9 - 4.4 lbs.)	2.2 - 2.7 kg (4.9 - 5.9 lbs.)	1.3 - 1.7 kg (2.8 - 3.8 lbs.)	1.2 - 1.4 kg (2.7 - 3.1 lbs.)

**ADP05 (AUBADP05)** 18V  
RM 161

**Adapter for USB**  
Penyesuai untuk USB  
USB适配器



- As a charger for smart phones

- Without Charger & Battery

<b>USB Port</b> Soket USB 插口位置	2 (A type)
<b>Dimensions (L x W x H)</b> Dimensi 体积	102x72x43mm (4"x2-13/16"x1-11/16")
<b>Net Weight</b> Berat Bersih 净重	0.46 - 0.71kg (1.0 - 1.6lbs)
<b>Work Amount (approx.)</b> Jumlah Kerja 工作量	10times with BL1830B Charging Iphone 6S (1715 mA-h)

\* All list price shown are for reference only (exclude SST).

\* Semua harga yang ditunjukkan adalah untuk rujukan sahaja (tidak termasuk SST). 所有显示的建议零售价仅供参考 (不包括SST)。

Cordless  
Target Kord 无绳式

LED Flashlight  
Lampu Suluh LED  
LED 手电筒

Vacuum Cleaner  
Pembersih Vakuum  
吸尘器

Drilling / Fastening  
Dua-dua / Pasang  
钻孔 / 紧固

Impact Drilling / Demolition  
Dua-dua / Penanggalan  
冲击钻孔 / 拆除加工

Cutting  
Pemotong  
切割

Grinding / Sanding  
Pengisar / Pasir  
磨削 / 打磨

Sawing  
Gergaji  
锯切

Planing / Routing  
Pengaliran / Tangkapan  
刨削 / 雕刻

Others  
Lain-lain  
其他

Outdoor Power Equipment  
Alatan Kerja Luar  
园具-户外



18V

LXT

12Vmax

CXT

Li-ion Ah 6.0 5.0 4.0 3.0 2.0 1.5

**ADP06 (AUAADP06)**  
RM 162.20

**ADP08 (AUAADP08) 12Vmax**  
RM 135.90

**Adapter for USB**  
Penyesuai untuk USB  
USB适配器



ADP06



ADP08



• As a charger for smart phones

• Without Charger & Battery

<b>Battery</b> Bateri 电池	12Vmax 1.5Ah, 2.0Ah, 4.0Ah
<b>USB Port</b> Soket USB USB接口位置	1 (type A)
<b>Devices</b> Peralatan 设备	iOS & Android
<b>Dimensions (L x W x H)</b> Dimensi 体积	80x53x38mm <b>ADP06</b> (3-1/8"x2-1/16"x1-1/2") 80x53x28mm <b>ADP08</b> (3-1/8"x2-1/16"x1-1/8")
<b>Net Weight</b> Berat Bersih 净重	0.27 - 0.44kg (0.6 - 1.0lbs)
<b>Work Amount</b> (approx.) Jumlah Kerja 工作量	1.3time charges with BL1021B <b>ADP06</b> Charging Iphone 7 (1960 mA-h) 1.5time charges with BL1021B <b>ADP08</b> Charging Iphone 7 (1960 mA-h)

# Cordless Coffee Maker

Mesin Kopi Tanpa Kord 充电式咖啡机

18V LITHIUM-ION  
18V 锂离子  
18V锂离子电池

12Vmax LITHIUM-ION  
12V 锂离子  
12V锂离子电池

Capacity of Cup



Makita Cafe pod 120mL  
Ground coffee (6.5g) 160mL

**Water Tank Capacity**  
Kapasiti Tangki Air  
水箱容量  
**240mL**

**Dedicated Cup Capacity**  
**240mL**

**Carry Handle**  
for easy transport  
Pemegang mudah dibawa  
手柄便于携带



**Makita genuine cafe pods are prepared** 20pcs/box



**Brazil**  
Fragrant bitter & deep flavor



**Mocha**  
Sweet scent & mild taste



**Kilimanjaro**  
Aftertaste with bitter sweet & sharpness

**Cover is slide left and right to protect the empty port when a battery is inserted**

Tutup adalah gelongsor kiri dan kanan untuk melindungi port kosong apabila bateri dimasukkan  
左右滑动保护盖，以在插入电池时保护空的端口

**DCM501Z 18V / 12Vmax**  
RM 830

**Cordless Coffee Maker**  
Mesin Kopi Tanpa Kord  
充电式咖啡机



• Large tank capacity of 240 mL

Standard Equipment: Mug, Measuring Spoon

• Z : Without Charger & Battery

<b>Water Tank Capacity</b> Dimensi 体积	240mL
<b>Compatible Cafe Pod Type</b> Berat Bersih 净重	60mm
<b>Dimensions (L x W x H)</b> Masa Penggunaan Berterusan 连续使用时间	243x187x218mm (9-9/16"x7-3/8"x8-9/16")
<b>Net Weight</b>	1.9 - 2.2kg (4.1 - 4.8lbs.)
<b>Continuous Usage Time (approx.)</b>	4cups 160mL Coffee with BL1860B

\* All list price shown are for reference only (exclude SST).

\* Semua harga yang ditunjukkan adalah untuk rujukan sahaja (tidak termasuk SST). 所有显示的建议零售价仅供参考 (不包括SST)。

Cordless  
Target: Kordless

LED Flashlight  
Lampu Suhu LED  
LED手电筒

Vacuum Cleaner  
Pembersih Vakuum  
吸尘器

Drilling / Fastening  
Ganda / Pengikat  
电钻 / 紧固件

Impact Drilling / Demolition  
Ganda / Penusuk  
冲击电钻 / 拆除工具

Cutting  
Pemotong  
切割机

Grinding / Sanding  
Pengisar / Poles  
研磨 / 打磨

Sawing  
Ganda  
锯切

Planing / Routing  
Pengiraian / Tumpang  
刨平 / 压板

Others  
Lain-lain  
其他

Outdoor Power Equipment  
Alatan Kuasa Luar  
户外动力设备

Makita  
1915



# Cordless Fan Jacket

Jaket Kipas Tanpa Kord 充电式风扇夹克



**Max Air Flow**  
Aliran Udara Maksimum  
最大空气流量  
**2.2m<sup>3</sup>/min**  
(Turbo Mode)

Model No.	Battery holder
DFJ201	
DFJ202 DFJ213 DFJ211 DFJ214 DFJ300 DFV210 DFJ311 FJ502D DFJ400 FJ203D DFJ411 FJ301D DFJ212 FJ401D	 <b>Battery Holder Set</b> Part No. 198732-2
	 <b>Battery Holder Set</b> Part No. 198731-4 (GM00001604)
DCV202 DCB200	 <b>Battery Holder Set</b> Part No. YL00000004
DCV202 CB100D	 <b>Battery Holder Set</b> Part No. YL00000003

## Jacket Size

saiz Jaket 夹克尺寸



## Fan Vest

	size (in cm)	S	M	L	XL	2XL	3XL
DFV210	Length	67	69	71	72	73	74
	Shoulder	43	45	47	49	51	53
	Chest	113	118	123	128	133	138
	Waist	107	112	117	122	127	132

## Heated Vest

	size (in cm)	S	M	L	XL	2XL	3XL
DCV202	Length	72	73	74	75	76	77
	Shoulder	47.5	49.5	51.5	53.5	55.5	57.5
	Chest	114	120	126	132	138	144
	Waist	116	122	128	134	140	146

## Fan Jacket

	size (in cm)	S	M	L	XL	2XL	3XL
DFJ212	Length	66	68	70	71	72	73
	Shoulder	44	46	48	50	52	54
	Sleeve*	87	90	93	95	97	99
	Chest	117	122	127	132	137	142
	Waist	111	116	121	126	131	136
DFJ213	Length	65	67	69	70	71	72
	Shoulder	47	49	51	53	55	57
	Sleeve	62	64	66	67	68	69
	Chest	117	122	127	132	137	142
DFJ214	Waist	103 ~ 111	108 ~ 116	113 ~ 121	118 ~ 126	123 ~ 131	128 ~ 136
	Length	68	70	72	73	74	75
	Shoulder	47	49	51	53	55	57
DFJ211	Sleeve	62	64	66	67	68	69
	Chest	117	122	127	132	137	142
	Waist	103 ~ 111	108 ~ 116	113 ~ 121	118 ~ 126	123 ~ 131	128 ~ 136
	Length	68	70	72	74	76	78
DFJ311	Shoulder	56.5	59	61.5	64	66.5	69
	Sleeve	58	60	62	64	66	68
DFJ411	Chest	126	131	136	141	146	151
	Waist	87 ~ 113	92 ~ 113	97 ~ 113	102 ~ 133	107 ~ 138	112 ~ 143

\* All list price shown are for reference only (exclude SST).

\* Semua harga yang ditunjukkan adalah untuk rujukan sahaja (tidak termasuk SST). 所有显示的建议零售价仅供参考 (不包括SST)。

Cordless  
Tanpa Kord 无绳式

LED Flashlight  
Lampu Suling LED  
LED 照明灯

Vacuum Cleaner  
Pembersih Vakuum  
吸尘器

Drilling / Fastening  
Dremel / Pengikat  
钻头 / 紧固件

Impact Drilling / Demolition  
Garuhi / Persekolah  
起工钻头 / 拆墙加工

Cutting  
Pemotong  
切割机

Grinding / Sanding  
Pengisar / Pucuk  
磨头 / 砂纸

Sawing  
Gergaji  
锯切

Planing / Routing  
Pengisar / Tangkapan  
刨头 / 刨床

Others  
Lain-lain  
其他

Outdoor Power Equipment  
Alatan Kerja Luar  
户外户外





Li-ion Ah 6.0 | 5.0 | 4.0 | 3.0 | 2.0 | 1.5

**FJ502DZM** RM 1,278 | **FJ502DZL** RM 1,278 | **FJ502DZLL** RM 1,278 18V / 12Vmax

**Cordless Fan Jacket**  
Jaket Kipas Tanpa Kord  
充电式风扇夹克

FJ502D  
ZM / ZL / ZLL



- Equipped with Two Flat Fan Units with BL Motor for Increased Comfort

• Without Charger & Battery



<b>Air Flow Settings</b> Tetapan Aliran Udara 空气流量设置	Turbo   High   Medium   Low
<b>Air Flow</b> Aliran Udara 空气流量	Turbo: 2.2m³/min   High: 2.1m³/min   Med: 1.7m³/min   Low: 1.5m³/min
<b>Size</b> Saiz 尺寸	M   L   LL

**DFJ211ZM** RM 762 | **DFJ211ZL** RM 762 | **DFJ211ZXL** RM 762 18V / 12Vmax

**Cordless Fan Jacket**  
Jaket Kipas Tanpa Kord  
充电式风扇夹克



DFJ211  
ZM / ZL / ZXL



- Equipped with Two Flat Fan Units with BL Motor for Increased Comfort

• Without Charger & Battery



<b>Air Flow Settings</b> Tetapan Aliran Udara 空气流量设置	Turbo   High   Medium   Low
<b>Air Flow</b> Aliran Udara 空气流量	Turbo: 2.2m³/min   High: 2.1m³/min   Med: 1.7m³/min   Low: 1.5m³/min
<b>Size</b> Saiz 尺寸	M   L   XL
<b>Pockets</b> Poket 口袋	5
<b>Net Weight</b> Berat Bersih 净重	0.41kg (0.9lbs.)
<b>Continuous Usage Time (approx.)</b> Masa Penggunaan Berterusan 连续使用时间	Low: 29 hrs   Medium: 21 hrs   High: 12 hrs with BL1850B

**Polyester** For general work

Untuk kerja am | 用于一般工作  
• Superior moisture permeability and water repellent

**DFJ311ZM** RM 800 | **DFJ311ZL** RM 800 | **DFJ311ZXL** RM 800 18V / 12Vmax

**Cordless Fan Jacket**  
Jaket Kipas Tanpa Kord  
充电式风扇夹克



DFJ311  
ZM / ZL / ZXL



- Equipped with Two Flat Fan Units with BL Motor for Increased Comfort

• Without Charger & Battery



<b>Air Flow Settings</b> Tetapan Aliran Udara 空气流量设置	Turbo   High   Medium   Low
<b>Air Flow</b> Aliran Udara 空气流量	Turbo: 2.2m³/min   High: 2.1m³/min   Med: 1.7m³/min   Low: 1.5m³/min
<b>Size</b> Saiz 尺寸	M   L   XL
<b>Pockets</b> Poket 口袋	5
<b>Net Weight</b> Berat Bersih 净重	0.52kg (1.1lbs.)
<b>Continuous Usage Time (approx.)</b> Masa Penggunaan Berterusan 连续使用时间	Low: 29 hrs   Medium: 21 hrs   High: 12 hrs with BL1850B

**Cotton** For welding/ grinding work

Untuk kerja kimpalan/ pengisaran | 用于焊接/ 打磨工作  
• Strong in heat and sparks

**DFJ411ZM** RM 965 | **DFJ411ZL** RM 965 | **DFJ411ZXL** RM 965 18V / 12Vmax

**Cordless Fan Jacket**  
Jaket Kipas Tanpa Kord  
充电式风扇夹克



DFJ411  
ZM / ZL / ZXL



- Equipped with Two Flat Fan Units with BL Motor for Increased Comfort

• Without Charger & Battery



<b>Air Flow Settings</b> Tetapan Aliran Udara 空气流量设置	Turbo   High   Medium   Low
<b>Air Flow</b> Aliran Udara 空气流量	Turbo: 2.2m³/min   High: 2.1m³/min   Med: 1.7m³/min   Low: 1.5m³/min
<b>Size</b> Saiz 尺寸	M   L   XL
<b>Pockets</b> Poket 口袋	5
<b>Net Weight</b> Berat Bersih 净重	0.49kg (1.1lbs.)
<b>Continuous Usage Time (approx.)</b> Masa Penggunaan Berterusan 连续使用时间	Low: 29 hrs   Medium: 21 hrs   High: 12 hrs with BL1850B

**Polyester + Titanium coating** For outdoor work

Untuk kerja luaran | 用于户外工作  
• Reflective in ultraviolet rays and infrared rays

**DFJ214ZM** RM 1,202 | **DFJ214ZL** RM 1,202 | **DFJ214ZXL** RM 1,202 18V / 12Vmax

**Cordless Fan Jacket**  
Jaket Kipas Tanpa Kord  
充电式风扇夹克



DFJ214  
ZM / ZL / ZXL



- Equipped with Two Flat Fan Units with BL Motor for Increased Comfort

• Without Charger & Battery



<b>Air Flow Settings</b> Tetapan Aliran Udara 空气流量设置	Turbo   High   Medium   Low
<b>Air Flow</b> Aliran Udara 空气流量	Turbo: 2.2m³/min   High: 2.1m³/min   Med: 1.7m³/min   Low: 1.5m³/min
<b>Size</b> Saiz 尺寸	M   L   XL
<b>Pockets</b> Poket 口袋	5
<b>Net Weight</b> Berat Bersih 净重	0.54kg (1.2lbs.)
<b>Continuous Usage Time (approx.)</b> Masa Penggunaan Berterusan 连续使用时间	Low: 29 hrs   Medium: 21 hrs   High: 12 hrs with BL1850B

**Polyester**

• water repellency, antistatic fabric

\* All list price shown are for reference only (exclude SST).

\* Semua harga yang ditunjukkan adalah untuk rujukan sahaja (tidak termasuk SST). 所有显示的建议零售价仅供参考 (不包括SST)。

Cordless  
Target: 4000 Jarak

LED Flashlight  
Lampu Suhu LED  
LED 1800mAh

Vacuum Cleaner  
Pembersih Vakuum  
1800W

Drilling / Fastening  
Gergaji / Pengikat  
18V / 1800W

Impact Drilling / Demolition  
Gergaji / Penusuk  
18V / 1800W

Cutting / Finishing  
Pangkas / Hiasan  
18V / 1800W

Grinding / Sanding  
Pengisar / Hiasan  
18V / 1800W

Sawing / Cutting  
Gergaji / Hiasan  
18V / 1800W

Planing / Routing  
Pengisar / Tangkapan  
18V / 1800W

Others  
Lain-lain  
18V

Outdoor Power Equipment  
Alatan Kerja Luar  
18V / 1800W





Li-ion Ah 6.0 5.0 4.0 3.0 2.0 1.5

Cordless Target Kord 无绳式

LED Flashlight Lampu Suluh LED LED 照明灯

Vacuum Cleaner Pemilauhi Vakuu 吸尘器

Drilling / Fastening Druai / Pengikat 钻式 / 螺丝

Impact Drilling / Demolition Druai / Penembak 钻式钻式 / 拆屋加工

Cutting Pemotong 切割

Grinding / Sanding Pengisar / Piskin 磨削 / 砂磨

Sawing Gergaji 锯切

Planing / Routing Pengisar / Tampam 刨削 / 磨削

Others Lain-lain 其他

Outdoor Power Equipment Alatan Kerja Luar 园具-户外



**DFJ212ZM** | **DFJ212ZL** | **DFJ212ZXL** 18V / 12Vmax  
RM 1,072 | RM 1,072 | RM 1,072

**Cordless Fan Jacket**  
Jaket Kipas Tanpa Kord  
充电式风扇夹克



DFJ212 ZM / ZL / ZXL

- Equipped with Two Flat Fan Units with BL Motor for Increased Comfort

• Without Charger & Battery



<b>Air Flow Settings</b> Tetapan Aliran Udara 空气流量设置	Turbo   High   Medium   Low
<b>Air Flow</b> Aliran Udara 空气流量	Turbo: 2.2m³/min   High: 2.1m³/min   Med: 1.7m³/min   Low: 1.5m³/min
<b>Size</b> Saiz 尺寸	M   L   XL
<b>Pockets</b> Poket 口袋	5
<b>Net Weight</b> Berat Bersih 淨重	0.43kg (0.9lbs.)
<b>Continuous Usage Time (approx.)</b> Masa Penggunaan Berterusan 连续使用时间	Low: 29 hrs   Medium : 21 hrs   High: 12 hrs with BL1850B

**Polyester**

- High repellency fabric

**DFJ213ZM** | **DFJ213ZL** | **DFJ213ZXL** 18V / 12Vmax  
RM 1,017 | RM 1,017 | RM 1,017

**Cordless Fan Jacket**  
Jaket Kipas Tanpa Kord  
充电式风扇夹克



DFJ213 ZM / ZL / ZXL

- Equipped with Two Flat Fan Units with BL Motor for Increased Comfort

• Without Charger & Battery



<b>Air Flow Settings</b> Tetapan Aliran Udara 空气流量设置	Turbo   High   Medium   Low
<b>Air Flow</b> Aliran Udara 空气流量	Turbo: 2.2m³/min   High: 2.1m³/min   Med: 1.7m³/min   Low: 1.5m³/min
<b>Size</b> Saiz 尺寸	M   L   XL
<b>Pockets</b> Poket 口袋	5
<b>Net Weight</b> Berat Bersih 淨重	0.54kg (1.2lbs.)
<b>Continuous Usage Time (approx.)</b> Masa Penggunaan Berterusan 连续使用时间	Low: 29 hrs   Medium : 21 hrs   High: 12 hrs with BL1850B

**Polyester**

- Stretchable fabric

**DFV210ZM** | **DFV210ZL** | **DFV210ZXL** 18V / 12Vmax  
RM 873 | RM 873 | RM 873

**Cordless Fan Vest**  
Jaket Kipas Tanpa Kord  
充电式风扇背心



DFV210 ZM / ZL / ZXL

- Equipped with Two Flat Fan Units with BL Motor for Increased Comfort

• Without Charger & Battery



<b>Air Flow Settings</b> Tetapan Aliran Udara 空气流量设置	Turbo   High   Medium   Low
<b>Air Flow</b> Aliran Udara 空气流量	Turbo: 2.2m³/min   High: 2.1m³/min   Med: 1.7m³/min   Low: 1.5m³/min
<b>Size</b> Saiz 尺寸	M   L   XL
<b>Pockets</b> Poket 口袋	5
<b>Net Weight</b> Berat Bersih 淨重	0.38kg (0.8lbs.)
<b>Continuous Usage Time (approx.)</b> Masa Penggunaan Berterusan 连续使用时间	Low: 29 hrs   Medium : 21 hrs   High: 12 hrs with BL1850B

**Polyester**

- High repellency fabric

**DFJ202ZL** | **DFJ202ZXL** | **FJ203DZL** | **FJ203DZLL** 18V / 12Vmax  
RM 710 | RM 710 | RM 760 | RM 760

**Cordless Fan Jacket**  
Jaket Kipas Tanpa Kord  
充电式风扇夹克



DFJ202 ZL / ZXL

FJ203 DZL / DZLL

- Powerful fan provides air flow to keep you cool

Standard Equipment: Fan Hook

• Without Charger & Battery



Stok sedia ada 售完即止  
**WHILE STOCK LAST**

<b>Air Flow Settings</b> Tetapan Aliran Udara 空气流量设置	Turbo   High   Medium   Low
<b>Air Flow</b> Aliran Udara 空气流量	Turbo: 1.4m³/min   High: 1.2m³/min   Med: 1.0m³/min   Low: 0.8m³/min
<b>Size</b> Saiz 尺寸	L   XL   LL
<b>Pockets</b> Poket 口袋	5
<b>Net weight</b> Berat Bersih 淨重	1.5 - 1.9kg (3.3 - 4.1lbs)
<b>Continuous Usage Time (approx.)</b> Masa Penggunaan Berterusan 连续使用时间	Low: 28 hrs   Medium : 20 hrs   High: 11 hrs with BL1850B

**Polyester For general work**

Untuk kerja am | 用于一般工作

- Superior moisture permeability and water repellent

**DFJ300ZXL** | **FJ301DZM** | **FJ301DZL** | **FJ301DZLL** 18V / 12Vmax  
RM 745 | RM 797 | RM 797 | RM 797

**Cordless Fan Jacket**  
Jaket Kipas Tanpa Kord  
充电式风扇夹克



DFJ300 ZXL

FJ301 DZM / DZL / DZLL

- 100% cotton - hardly-burned, suitable for welding/ grinding

Standard Equipment: Fan Hook

• Without Charger & Battery



<b>Air Flow Settings</b> Tetapan Aliran Udara 空气流量设置	Turbo   High   Medium   Low
<b>Air Flow</b> Aliran Udara 空气流量	Turbo: 1.4m³/min   High: 1.2m³/min   Med: 1.0m³/min   Low: 0.8m³/min
<b>Size</b> Saiz 尺寸	DFJ300: XL FJ301: M   L   LL
<b>Pockets</b> Poket 口袋	5
<b>Net weight</b> Berat Bersih 淨重	1.5 - 1.9kg (3.3 - 4.1lbs)
<b>Continuous Usage Time (approx.)</b> Masa Penggunaan Berterusan 连续使用时间	Low: 29 hrs   Medium : 21 hrs   High: 12 hrs with BL1850B

**Cotton For welding/ grinding work**

Untuk kerja kimpalan/ pengisaran | 用于焊接/ 打磨工作

- Strong in heat and sparks

\* All list price shown are for reference only (exclude SST).

\* Semua harga yang ditunjukkan adalah untuk rujukan sahaja (tidak termasuk SST). 所有显示的建议零售价仅供参考 (不包括SST)。





**DFJ400ZXL** RM 848 | **FJ401DZL** RM 970 | **FJ401DZLL** RM 970 | **FJ401DZ3L** RM 970 18V / 12Vmax

**Cordless Fan Jacket**  
Jaket Kipas Tanpa Kord  
充电式风扇夹克



DFJ400 ZXL

FJ401 DZL / DZLL / DZ3L

- Heavy-duty shoulder pad lightens the burden on a shoulder and prevents torn while carrying reinforcing bars

Standard Equipment: Fan Hook

- Without Charger & Battery



<b>Air Flow Settings</b> Tetapan Aliran Udara 空气流量设置	Turbo   High   Medium   Low
<b>Air Flow</b> Aliran Udara 空气流量	Turbo: 1.4m³/min   High: 1.2m³/min   Med: 1.0m³/min   Low: 0.8m³/min
<b>Size</b> Saiz 尺寸	DFJ400: XL FJ401: L   LL   3L
<b>Pockets</b> Poket 口袋	5
<b>Net weight</b> Berat Bersih 淨重	1.5 - 1.9kg (3.3 - 4.1lbs)
<b>Continuous Usage Time (approx.)</b> Masa Penggunaan Berterusan 连续使用时间	Low: 28 hrs   Medium: 20 hrs   High: 11 hrs with BL1850B

**Polyester + Titanium processing** For outdoor work  
Untuk kerja luaran | 用于户外工作

- Reflective in ultraviolet rays and infrared rays

**DFJ201ZM** RM 710 | **DFJ201ZL** RM 710 | **DFJ201ZXL** RM 710 18V

**Cordless Fan Jacket**  
Jaket Kipas Tanpa Kord  
充电式风扇夹克



DFJ201 ZM / ZL / ZXL

- Stay cool in hot harsh job site environments

Standard Equipment: Battery Holder

- Without Charger & Battery



<b>Air Flow Settings</b> Tetapan Aliran Udara 空气流量设置	Turbo   High   Medium   Low
<b>Air Flow</b> Aliran Udara 空气流量	Turbo: 1.4m³/min   High: 1.2m³/min   Med: 1.0m³/min   Low: 0.8m³/min
<b>Size</b> Saiz 尺寸	M   L   XL
<b>Pockets</b> Poket 口袋	3
<b>Net weight</b> Berat Bersih 淨重	660g (1.5lbs)
<b>Continuous Usage Time (approx.)</b> Masa Penggunaan Berterusan 连续使用时间	Low: 28 hrs   Medium: 20 hrs   High: 11 hrs with BL1850B

**Polyester** For general work  
Untuk kerja am | 用于一般工作

- Superior moisture permeability and water repellent

# Cordless Heated Vest

Ves Pemanas Tanpa Kord 充电式发热背心

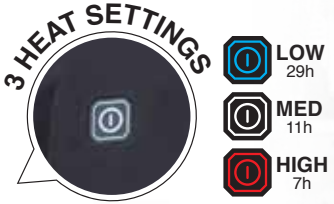

**Washable & Dryable**  
basuh dan Kering  
水洗和烘干

\*Detach the battery holder from the jacket or vest before washing

**Heating Effects**  
Fungsi Pemanasan 发热效果

When wearing in a minus 5°C environment (in High mode)  
Apabila memakai dalam persekitaran suhu 5°C (dalam mod Tinggi) 在零下5°C的环境中佩戴 (高级模式)

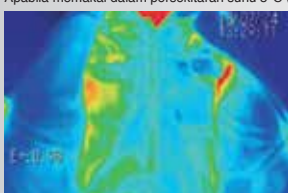

when switch is off

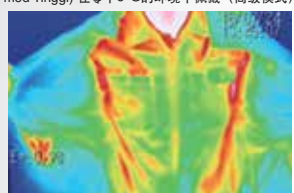

about 15 minutes after switch-on

**DCV202YXL** 18V RM 940

**Cordless Heated Vest**  
Ves Pemanas Tanpa Kord  
充电式发热背心



DCV202 YXL

- Stay warm in cold harsh job site environments

- Without Charger & Battery

<b>Heat Zones</b> Tetapan Aliran Udara 發熱區域	Total: 4   Chest: 2   Back: 2
<b>Heat Settings</b> Aliran Udara 加熱設定	High   Medium   Low
<b>Heat Value</b> Aliran Udara 加熱值	High: 9.5W   Mid: 4.5W   Low: 2.3W
<b>Size</b> Saiz 尺寸	XL
<b>Pockets</b> Poket 口袋	4
<b>Net Weight</b> Berat Bersih 淨重	0.5kg (1.1lbs.)
<b>Continuous Usage Time (approx.)</b> Masa Penggunaan Berterusan 连续使用时间	Low: 29 hrs   Medium: 17 hrs   High: 8 hrs with BL1850B

**Polyester**

- High repellency fabric

\* All list price shown are for reference only (exclude SST).

\* Semua harga yang ditunjukkan adalah untuk rujukan sahaja (tidak termasuk SST). 所有显示的建议零售价仅供参考 (不包括SST)。

Cordless Targeted Jobs

LED Flashlight Lampu Suhu LED LED 照明灯

Vacuum Cleaner Pembasmi Vakuum 吸尘器

Drilling / Fastening Gergaji / Pengikat 钻孔 / 紧固

Impact Drilling / Demolition Gergaji / Pemusnah 冲击钻孔 / 拆除施工

Cutting Pemotong 切割

Grinding / Sanding Penggosok / Poles 研磨 / 打磨

Sanding Gergaji 锯切

Planing / Routing Pengaliran / Tunggam 刨削 / 雕刻

Others Lain-lain 其他

Outdoor Power Equipment Alatan Kerja Luar 户外户外





# Cordless Heated Blanket

Selimut Elektrik Tanpa Kord 充电式电热毯

## Battery pocket

Butang kuasa 电源按钮



## 1.5m Extension cord

Butang kuasa 电源按钮



\*Masa Penggunaan Berterusan  
连续使用时间

**Continuous Usage Time**  
with BL1850B  
(Low Mode)

**29hrs**  
(approx.)

\* Continuous Usage Time/ Work Amount:  
Actual performance may vary based on application.  
Masa Penggunaan Berterusan/ Jumlah Kerja: Prestasi sebenar  
mungkin berbeza mengikut aplikasi.  
连续使用时间/ 之工作量: 实际使用可能因应用而异。



**Washable & Dryable**  
basuh dan Kering  
水洗和烘干

Be sure to remove the battery holder from the blanket before washing and drying

## Power button

To turn on the blanket, press and hold the power button for a few seconds. To turn off, press and hold the power button again

Butang kuasa 电源按钮

## Temperature adjustment

There are three temperature settings (high, medium, low)

Pelarasan suhu 温度调节

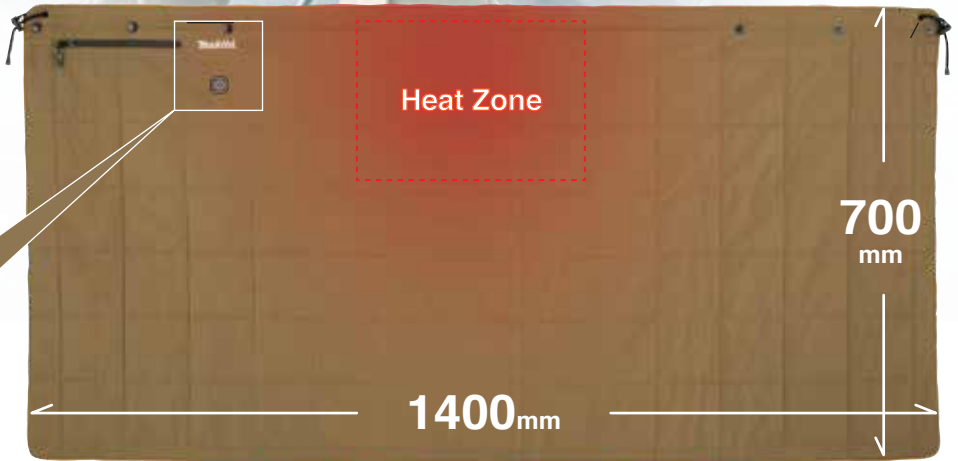
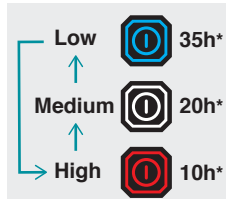

\*Continuous runtime on a single full battery charge with BL1860B (18V-6.0Ah Battery)

## DCB200B 18V

RM 1,043

### Cordless Heated Blanket

Selimut Elektrik Tanpa Kord  
充电式电热毯



- Machine-washable and machine-dryable

Standard Equipment: Battery Holder,  
Storage Bag, Extension Cord

- Without Charger & Battery

<b>Heat Zone</b> Tetapan Aliran Udara 发热区域	Upper Center: 1
<b>Heat Settings</b> Aliran Udara 加热设定	High   Medium   Low
<b>Heat Value</b> Aliran Udara 加热值	High: 9.5W   Med: 4.5W   Low: 2.3W
<b>Dimensions (L x W)</b> Dimensi 体积	700x1,400mm (27-1/2"x55")
<b>Net Weight</b> Berat Bersih 净重	0.58kg (1.28lbs.)
<b>Continuous Usage Time (approx.)</b> Masa Penggunaan Berterusan 连续使用时间	Low: 29 hrs   Med: 16.5 hrs   High: 8 hrs with BL1850B

## CB100DB 12Vmax

RM 1,043

### Cordless Heated Blanket

Selimut Elektrik Tanpa Kord  
充电式电热毯



- Machine-washable and machine-dryable

Standard Equipment: Battery Holder,  
Storage Bag, Extension Cord

- Without Charger & Battery

<b>Heat Zone</b> Tetapan Aliran Udara 发热区域	Upper Center: 1
<b>Heat Settings</b> Aliran Udara 加热设定	High   Medium   Low
<b>Heat Value</b> Aliran Udara 加热值	High: 9.5W   Med: 4.5W   Low: 2.3W
<b>Dimensions (L x W)</b> Dimensi 体积	700x1,400mm (27-1/2"x55")
<b>Net Weight</b> Berat Bersih 净重	0.58kg (1.28lbs.)
<b>Continuous Usage Time (approx.)</b> Masa Penggunaan Berterusan 连续使用时间	Low: 14 hrs   Med: 7.5 hrs   High: 4 hrs with BL1041B

\* All list price shown are for reference only (exclude SST).

\* Semua harga yang ditunjukkan adalah untuk rujukan sahaja (tidak termasuk SST). 所有显示的建议零售价仅供参考 (不包括SST)。

Cordless  
Target Kord 无绳式

LED Flashlight  
Lampu Suluh LED  
LED手电筒

Vacuum Cleaner  
Pembersih Vakuum  
吸尘器

Drilling / Fastening  
Draut / Pengetat  
钻 / 紧固

Impact Drilling / Demolition  
Draut / Penembak  
钻 / 拆除加工

Cutting  
Pemotong  
切割机

Grinding / Sanding  
Pengisar / Pasukan  
磨 / 打磨

Sawing  
Gergaji  
电锯

Planing / Routing  
Pengaram / Tangkapan  
刨 / 雕刻

Others  
Lain-lain  
其他

Outdoor Power Equipment  
Alatan Kerja Luar  
园具-户外

Makita  
1921

# LED FLASHLIGHT

Lampu Suluh LED LED照明灯

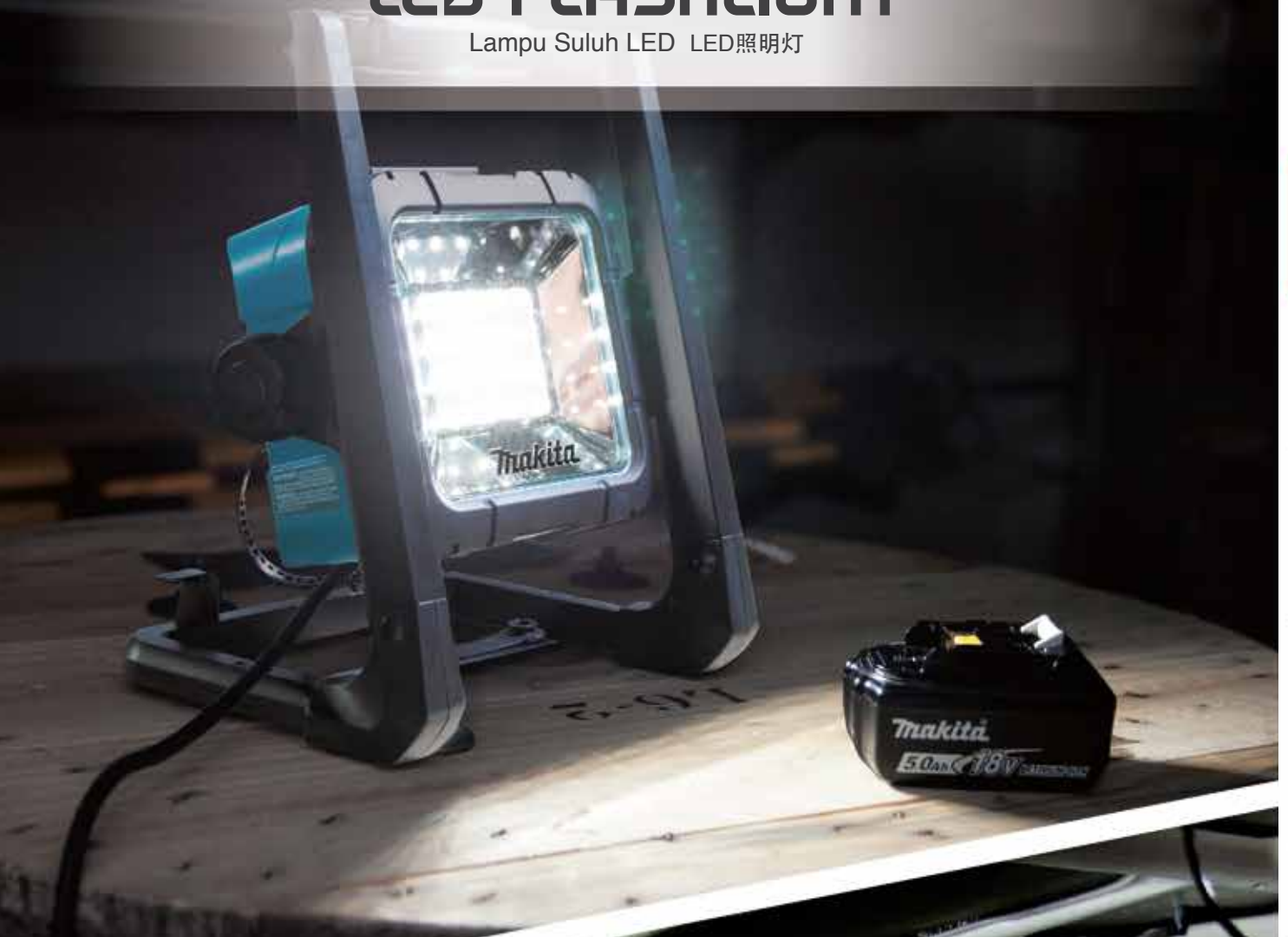

Cordless  
Tersedia dalam 30.000.000.000

LED Flashlight  
Lampu Suluh LED  
LED照明灯

Vacuum Cleaner  
Pembersihan Vakuüm  
吸尘器

Drilling | Fastening  
Cairus | Penggasing  
钻孔 | 紧固

Impact Drilling | Demolition  
Cairus | Pemecahan  
打孔/钻孔 | 拆毁/拆工

Cutting  
Pemotong  
切割机

Grinding | Sanding  
Penghalus | Pasiran  
打磨 | 砂磨

Sawing  
Cergas  
锯切

Planing | Routing  
Penghalus | Tumpang  
刨平 | 榫嵌

Others  
Lain-lain  
其他

Outdoor Power Equipment  
Alatan Kerja Luar  
室外动力工具



Makita  
THE POWER OF TOOLS

18V

LXT

Li-ion Ah 6.0 | 5.0 | 4.0 | 3.0 | 2.0 | 1.5

# Cordless Area Worklight

Lampu Kerja Kawasan Tanpa Kord 充电式区域工作灯

**Light Diffusing Lens**  
202 super luminous daylight white LEDs:  
40.4W (0.2W x 202)

**Inlet type AC power supply cord**  
Detachable and can be stored compactly on the back of the light body  
Wayar elektrik boleh disimpan dengan padat di bahagian belakang badan lampu  
电源线可紧凑地存放在灯体的背面

**Switch**  
Panel Kawalan 控制面板

**Reflector**  
Glow in the dark  
Bercahaya dalam gelap  
黑暗中发光

## Adjustable illumination area



Controller with memory function remembers the brightness setting and the lighting area setting last time you power off, allowing the user to avoid adjusting again.  
Pengawal dengan fungsi memori mengingati tetapan kecerahan dan tetapan kawasan pencahayaan ketika terakhir anda mematikan, membolehkan pengguna mengelakkan penyesuaian lagi.  
具有存储功能的控制器会在您上次关闭电源时记住亮度设置和照明区域设置，从而使用户避免再次进行调整。

## 3-stage brightness switch



Low	Medium	High
1,500 lm	3,000 lm	5,500 lm
18 h	8.5 h	4.0 h

Continuous run time (Battery : BL1860Bx2)

## DML810 18V / AC

Price TBA

**Cordless Area Worklight**  
Lampu Kerja Kawasan Tanpa Kord  
充电式区域工作灯



- Self-righting design won't fall over even if bumped



Standard Equipment: AC Power Cord

- Without Charger & Battery

<b>Luminous Flux</b> Cahaya Fluks 发光通量	High: 5,500lm   Mid: 3,000lm   Low: 1,500lm
<b>illumination</b> Pencahayaan 照度	at 1m from the light source: 550 / 300 / 150 lx at 3m from the light source: 70 / 40 / 20 lx at 5m from the light source: 25 / 15 / 7 lx
<b>Dimensions (L x W x H)</b> Dimensi 体积	420x420x787mm (16-1/2"x16-1/2"x31")
<b>Net Weight</b> Berat Bersih 净重	13.9 - 15.3kg (30.6 - 33.7lbs.)
<b>Continuous Usage Time (approx.)</b> Masa Penggunaan Berterusan 连续使用时间	18 hrs with BL1850B x2

## DML808 (AUAML808) 18V

RM 329.50

**Cordless LED Flashlight**  
Lampu Suluh LED Tanpa Kord  
充电式LED照明灯

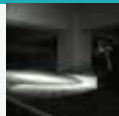

- Multifaceted Reflector Illuminates Evenly for Increased Visibility



- Without Charger & Battery

<b>Luminous Flux</b> Cahaya Fluks 发光通量	190lm
<b>illumination</b> Pencahayaan 照度	at 1m from the light source: 170 - 4,500lx
<b>Dimensions (L x W x H)</b> Dimensi 体积	297x79x119mm (11-3/4"x3-1/8"x4-11/16")
<b>Net Weight</b> Berat Bersih 净重	0.73 - 1.09kg (1.6 - 2.4lbs)
<b>Continuous Usage Time (approx.)</b> Masa Penggunaan Berterusan 连续使用时间	26 hrs with BL1850B

## DML807 (AUBDML807) 18V

Price TBA

**Cordless LED Flashlight**  
Lampu Suluh LED Tanpa Kord  
充电式LED照明灯



- USB power supply switch with auto-off function for saving battery power



- Without Charger & Battery

<b>Main light (on bar side)</b> Lampu Utama 主灯	<b>Luminous flux (Full brightness):</b> 710 lm <b>illumination (Full brightness):</b> 340 lx <b>Luminous flux (Half brightness):</b> 340 lm <b>illumination (Half brightness):</b> 310 lx
<b>Sub light (on top side)</b> Lampu Tambahan 副灯	<b>Luminous flux:</b> 130 lm <b>illumination:</b> 1,900 lx
<b>Dimensions (L x W x H)</b> Dimensi 体积	414x79x155mm (16-1/4"x3-1/8"x6-1/8")
<b>Net Weight</b> Berat Bersih 净重	0.72 - 1.1kg (1.6 - 2.4lbs.)
<b>Continuous Usage Time (approx.)</b> Masa Penggunaan Berterusan 连续使用时间	43 hrs with BL1850B

\* All list price shown are for reference only (exclude SST).

\* Semua harga yang ditunjukkan adalah untuk rujukan sahaja (tidak termasuk SST). 所有显示的建议零售价仅供参考 (不包括SST)。

Cordless 充电式  
LED Flashlight 充电式LED照明灯  
Vacuum Cleaner 吸尘器  
Drilling / Fastening 钻孔 / 紧固  
Impact Drilling / Demolition 冲击钻 / 拆除  
Cutting 切割  
Grinding / Sanding 打磨 / 研磨  
Sawing 锯切  
Planing / Routing 刨削 / 雕刻  
Others 其他  
Outdoor Power Equipment 户外动力设备



18V

LXT

Li-ion Ah 6.0 | 5.0 | 4.0 | 3.0 | 2.0 | 1.5

# Cordless Flashlight

Lampu Suluh Tanpa Kord 充电式照明灯



**Variable-angle head**  
Sudut laras 可调角度



**Switch**  
Panel Kawalan 控制面板

**4 Mode switch**  
Suis 4 Mod 4模式开关



**Hook**  
cangkuk 钩

**4 MODES**

600lm	1,250lm
<b>Spot</b>	<b>Spot + Flood</b>
1,000lm	1,250lm
<b>Flood</b>	<b>Strobe</b>



**DML812 (TWADML812) 18V**  
Price TBA

**Cordless Flashlight**  
Lampu Suluh Tanpa Kord  
充电式照明灯



**NEW**  
BARU / 新

- Super luminous daylight white LEDs

Standard Equipment: Strap Hook

- Without Charger & Battery



<b>Luminous Flux</b> Cahaya Fluks 发光通量	Spot: 600 lm   Flood: 1,000 lm   Spot-Flood: 1,250 lm
<b>illuminance</b> Pencahayaannya 照度	Spot: 71,000 lx   Flood: 520 lx   Spot-Flood: 51,000 lx
<b>Dimensions (L x W x H)</b> Dimensi 体积	313x119x115mm (12-3/8"x4-11/16"x4-1/2")
<b>Net Weight</b> Berat Bersih 净重	1.2 - 1.6kg (2.6 - 3.4lbs.)
<b>Continuous Usage Time (approx.)</b> Masa Penggunaan Berterusan 连续使用时间	Spot: 8.5 hrs   Flood: 6.5 hrs   Spot-Flood: 5.0 hrs   Strobe: 7.0 hrs with BL1850B

**DML802 (DEADML802) 18V**  
RM 319

**Cordless LED Flashlight**  
Lampu Suluh LED Tanpa Kord  
充电式LED照明灯



- 12 position pivoting flashlight head with positive stops from -60° - 110°

- Without Charger & Battery

<b>Dimensions (L x W x H)</b> Dimensi 体积	272x79x116mm (10-3/4"x3-1/8"x4-9/16")
<b>Net Weight</b> Berat Bersih 净重	0.65kg (1.5lbs)
<b>Continuous Usage Time (approx.)</b> Masa Penggunaan Berterusan 连续使用时间	20 hrs with BL1850B

**DML801 (DEADML801) 18V**  
RM 297.70

**Cordless LED Flashlight**  
Lampu Suluh LED Tanpa Kord  
充电式LED照明灯



- Metal hang hook swivels 360° and folds away for extra convenience

- Without Charger & Battery

<b>Dimensions (L x W x H)</b> Dimensi 体积	380x79x116mm (15"x9-11/16"x4-9/16")
<b>Net Weight</b> Berat Bersih 净重	0.68kg (1.5lbs)
<b>Continuous Usage Time (approx.)</b> Masa Penggunaan Berterusan 连续使用时间	15 hrs with BL1850B

\* All list price shown are for reference only (exclude SST).  
\* Semua harga yang ditunjukkan adalah untuk rujukan sahaja (tidak termasuk SST). 所有显示的建议零售价仅供参考 (不包括SST)。

Cordless  
Tempa Kord 无线式

LED Flashlight  
Lampu Suluh LED  
LED照明灯

Vacuum Cleaner  
Pembersih Vakuam  
吸尘器

Drilling | Fastening  
Cetus | Pengikat  
钻孔 | 紧固

Impact Drilling | Demolition  
Gerus | Hancurkan  
红工钻孔 | 敲击施工

Cutting  
Pemotong  
切割

Grinding | Sanding  
Pengisar | Pasir  
打磨 | 砂磨

Sawing  
Cergas  
锯切

Planing | Routing  
Moyokan | Tunggam  
刨削 | 雕刻

Others  
Lain-lain  
其他

Outdoor Power Equipment  
Alatan Kerja Luar  
园具/户外

Makita  
1915



Cordless  
Tanpa Kord / 无线式

LED Flashlight  
Lampu Suluh LED  
LED照明灯

Vacuum Cleaner  
Pembersih Vakuum  
吸尘器

Drilling / Fastening  
Drill / Pengikat  
钻孔 / 紧固

Impact Drilling / Demolition  
Drill / Penusuk  
冲击钻 / 拆除加工

Cutting  
Pemotong  
切割

Grinding / Sanding  
Pengkil / Pasir  
打磨 / 打磨

Sawing  
Gergaji  
锯切

Planing / Routing  
Pengkilan / Rangkaian  
刨削 / 雕刻

Others  
Lain-lain  
其他

Outdoor Power Equipment  
Alat-alat Kerja Luar  
园具-户外

**DML805 (GBDML805) 18V / AC**  
RM 985.50

**Corded and Cordless LED Worklight**

Lampu Kerja LED Kuasa Elektrik dan Tanpa Kord  
电源及充电式LED工作灯



- 2-mode operation: delivers 750 lumens on high mode or 450 lumens on low mode

• Without Charger & Battery

<b>Luminous Flux</b> Cahaya Fluks 发光通量	Hi: 750lm, Lo: 450lm
<b>illuminance</b> Pencahayaannya 照度	at 0.5m from the light source Hi: 1,150lx, Lo: 750lx at 1m from the light source Hi: 300lx, Lo: 200lx
<b>Dimensions (L x W x H)</b> Dimensi 体积	214x261x328mm (8-3/8"x10-1/4"x12-7/8")
<b>Net Weight</b> Berat Bersih 净重	2.3 - 2.7kg (5.1 - 5.9lbs)
<b>Continuous Usage Time (approx.)</b> Masa Penggunaan Berterusan 连续使用时间	10.5 hrs with BL1850B

**DML186 (DEADML186) 18V**  
RM 103.10

**Cordless LED Flashlight**  
Lampu Suluh LED Tanpa Kord  
充电式LED工作灯



- Hand strap for extra convenience

• Without Charger & Battery

<b>Dimensions (L x W x H)</b> Dimensi 体积	151x81x61mm (5-7/8"x3-3/16"x2-3/8")
<b>Net Weight</b> Berat Bersih 净重	0.54kg (1.18lbs)
<b>Continuous Usage Time (approx.)</b> Masa Penggunaan Berterusan 连续使用时间	50 hrs with BL1850B

**ML104 (AUAML104) 12Vmax**  
Price TBA

**Cordless LED Flashlight**  
Lampu Suluh LED Tanpa Kord  
充电式LED照明灯

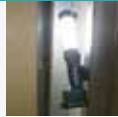

- USB power supply switch with auto-off function for saving battery power

• Without Charger & Battery

<b>Main light (on bar side)</b> Lampu Utama 主灯	<b>Luminous flux (Full brightness): 710 lm</b> <b>illuminance (Full brightness): 340 lx</b>
<b>Sub light (on top side)</b> Lampu Tambahan 副灯	<b>Luminous flux: 130 lm</b> <b>illuminance: 1,900 lx</b>
<b>Dimensions (L x W x H)</b> Dimensi 体积	414x66x132mm (16-1/4"x2-5/8"x5-3/16")
<b>Net Weight</b> Berat Bersih 净重	0.61 - 0.78 kg (1.4 - 1.7 lbs.)
<b>Continuous Usage Time (approx.)</b> Masa Penggunaan Berterusan 连续使用时间	19 hrs with BL1041B

**ML105 (AUAML105) 12Vmax**  
RM 303.70

**Cordless LED Flashlight**  
Lampu Suluh LED Tanpa Kord  
充电式LED手电筒



- Multifaceted Reflector Illuminates Evenly for Increased Visibility

Standard Equipment: Strap Hook

• Without Charger & Battery

<b>Luminous Flux</b> Cahaya Fluks 发光通量	190lm
<b>illuminance</b> Pencahayaannya 照度	at 1m from the light source 5,500lx
<b>Dimensions (L x W x H)</b> Dimensi 体积	249x66x93mm (9-3/4"x2-5/8"x3-5/8")
<b>Net Weight</b> Berat Bersih 净重	0.53 - 0.70kg (1.2 - 1.5lbs.)
<b>Continuous Usage Time (approx.)</b> Masa Penggunaan Berterusan 连续使用时间	7 hrs with BL1021B

**ML106 (AUAML106) 12Vmax**  
RM 329.50

**Cordless LED Flashlight**  
Lampu Suluh LED Tanpa Kord  
充电式LED手电筒



- Multifaceted Reflector Illuminates Evenly for Increased Visibility

Standard Equipment: Strap Hook

• Without Charger & Battery

<b>Luminous Flux</b> Cahaya Fluks 发光通量	190lm
<b>illuminance</b> Pencahayaannya 照度	at 1m from the light source 170 - 4,500lx
<b>Dimensions (L x W x H)</b> Dimensi 体积	271x66x93mm (10-5/8"x2-5/8"x3-5/8")
<b>Net Weight</b> Berat Bersih 净重	0.61 - 0.78kg (1.3 - 1.7lbs)
<b>Continuous Usage Time (approx.)</b> Masa Penggunaan Berterusan 连续使用时间	6 hrs with BL1021B



VIDEO CLIP  
Models and prices may vary by country

\* All list price shown are for reference only (exclude SST).

\* Semua harga yang ditunjukkan adalah untuk rujukan sahaja (tidak termasuk SST). 所有显示的建议零售价仅供参考 (不包括SST)。



**ML103 (AUAML103) 12Vmax**  
RM 175.50

**Cordless LED Flashlight**  
Lampu Suluh LED Tanpa Kord  
充电式LED手电筒



• 1.5W white single diffusion LED provides bright and wide illumination

• Without Charger & Battery

**Dimensions (L x W x H)** 77x54x28mm  
(3x2-1/8x1-1/8")  
**Net Weight** 0.27 - 0.43kg (0.6 - 1.0lbs)  
Berat Bersih 淨重  
**Continuous Usage Time (approx.)** 14 hrs with BL1021B  
Masa Penggunaan Berterusan 连续使用时间

## Product Comparison List 18V 12V max AC

Senarai Perbandingan Produk 产品对比表

	DML808	ML106	DML802	ML105	DML801	DML186
	Zoom Function	Zoom Function				
<b>Run time (hrs)</b>	Up to: 26 with BL1850B	Up to: 12 with BL1041B	Up to: 23 with BL1850B	Up to: 14 with BL1041B	Up to: 17 Full: with BL1850B Up to: 40 Half: with BL1850B	Up to: 95 with BL1850B
<b>Illuminance</b>	170 - 4,500lx at 1m from the light	170 - 4,500lx at 1m from the light	4,000lx at 1m from the light	5,500lx at 1m from the light	Full: 400lx Half: 200lx at 0.5m from the light	500lx at 1m from the light
<b>Luminous flux (lm=lumens)</b>	190lm	190lm	180lm	190lm	Full: 240lm Half: 120lm	-
<b>Net weight</b>	0.73 - 1.09kg (1.6 - 2.4lbs)	0.61 - 0.78kg (1.3 - 1.7lbs)	0.64 - 1.0kg (1.4 - 2.2lbs)	0.53 - 0.70kg (1.2 - 1.5lbs)	0.61 - 0.98kg (1.4 - 2.2lbs)	0.51 - 0.83kg (1.1 - 1.8lbs)

	DML807	ML104	DML812	DML810	DML805	ML103
	XPT	XPT				
<b>Run time (hrs)</b>	Up to: 23 Main light (1/2) with BL1850B Up to: 36 Sub light with BL1850B	Up to: 17 Main light (1/2) with BL1041B Up to: 19 Sub light with BL1041B	Up to: 8 with BL1850B	Up to: 15 with BL1850B x2	Up to: 8.5 Hi: with BL1850B Up to: 17 Lo: with BL1850B	Up to: 28 with BL1041B
<b>Illuminance</b>	Main light (Full): 340lx Main light (1/2): 310lx Sub light (On Top): 1,900lx at 0.5m from the light	Main light (Full): 340lx Main light (1/4): 190lx Sub light (On Top): 1,900lx at 0.5m from the light	71,000lx   51,000lx   520lx at 1m from the light	550lx   300lx   150lx at 1m from the light	Hi: 1,150lx, Lo: 750lx at 0.5m from the light Hi: 300lx, Lo: 200lx at 1m from the light	240lx at 0.5m from the light 50lx at 1m from the light
<b>Luminous flux (lm=lumens)</b>	Main light (Full): 710lm Main light (1/2): 340lm Sub light (On Top): 130lm	Main light (Full): 710lm Main light (1/4): 190lm Sub light (On Top): 130lm	Spot: 600lm Spot/ Flood: 1,250lm Flood: 1,000lm	High: 5,500lm Med: 3,000lm Low: 1,500lm	Hi: 750lm Lo: 450lm	100lm
<b>Net weight</b>	0.72 - 1.1kg (1.6 - 2.4lbs)	0.61 - 0.78kg (1.4 - 1.7lbs)	1.7kg (3.8lbs)	13.9 - 15.3kg (30.6 - 33.7lbs)	2.3 - 2.7kg (5.1 - 5.9lbs)	0.27 - 0.43kg (0.6 - 1.0lbs)

\* All list price shown are for reference only (exclude SST).

\* Semua harga yang ditunjukkan adalah untuk rujukan sahaja (tidak termasuk SST). 所有显示的建议零售价仅供参考 (不包括SST)。

Cordless  
Tanpa Kord 无绳式

LED Flashlight  
Lampu Suluh LED  
LED手电筒

Vacuum Cleaner  
Pembersih Vakuam  
吸尘器

Drilling / Fastening  
Gergasi / Pengikat  
钻头 / 紧固件

Impact Drilling / Demolition  
Gergasi / Pecutan  
冲击钻头 / 冲击器

Cutting  
Pemotong  
切割机

Grinding / Sanding  
Pengkilan / Pasiran  
打磨 / 砂磨

Sawing  
Gergasi  
锯机

Planing / Routing  
Pengkilan / Tumpang  
刨机 / 压板机

Others  
Lain-lain  
其他

Outdoor Power Equipment  
Alatan Kerja Luar  
户外动力工具

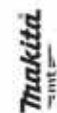

# VACUUM CLEANER

Pembersih Vakum 吸尘器

Cordless  
Tanpa Kabel Listrik

LED Flashlight  
Lampu Senter LED  
LED 照灯

Vacuum Cleaner  
Pembersih Vakum  
吸尘器

Drilling | Fastening  
Drobul | Pengikat  
钻孔 | 紧固

Impact Drilling | Demolition  
Drobul | Persekolah  
冲击钻孔 | 拆除加工

Cutting  
Pemotong  
切割

Grinding | Sanding  
Pengkilan | Pasir  
打磨 | 砂磨

Sawing  
Gergaji  
锯切

Planing | Routing  
Pengaliran | Tenggam  
刨削 | 雕刻

Others  
Lain-lain  
其他

Outdoor Power Equipment  
Alat-alat Kerja Luar  
园具·户外







Li-ion Ah 6.0 | 5.0 | 4.0 | 3.0 | 2.0 | 1.5



**DVC150LZ**  
RM 6,217

**Corded & Cordless Vacuum Cleaner (Wet & Dry)**  
Pembersih Vakum Kuasa Elektrik Dan Tanpa Kord (Basah dan Kering)  
充电式 + 电源驱动吸尘器(干湿两用)



**WET**  
Basah 湿  
**DRY**  
Kering 干

- For both wet and dry vacuum cleaning

**Standard Equipment:** Floor Nozzle, Corner Nozzle, Straight Pipe, Bent Pipe, Hose (38mm), Plastic Dust Bag, Plastic Dust Bag x10, Cloth Filter, Tool Box, Connection Cord

- Z: Without Charger & Battery



<b>Capacity</b> Kapasiti 尘袋容量	Dust: 15L   Water: 12L
<b>Max Air Flow</b> Aliran Udara 最大空气流量	AC: 3.6m³/min   DC: 2.1m³/min
<b>Max Sealed Suction</b> Sedutan Terkedap 最大密封吸力	AC: 24kPa   DC: 9kPa
<b>Suction Power</b> Kuasa Sedutan 吸力	AC: 320W   DC: 25 - 70W
<b>Dimensions (L x W x H)</b> Dimensi 体积	366x334x421mm (14-3/8"x13-1/8"x16-1/2")
<b>Net Weight</b> Berat Bersih 净重	8.9 - 9.6kg (19.7 - 21.1lbs.)
<b>Continuous Usage Time (approx.)</b> Masa Penggunaan Berterusan 连续使用时间	65 min with BL1850B x2

**DVC151LZ**  
RM 7,038

**Corded and Cordless Vacuum Cleaner (Dry)**  
Pembersih Vakum Kuasa Elektrik Dan Tanpa Kord (Kering)  
充电式 + 电源驱动吸尘器(干用)



**DRY**  
Kering 干

- 15L Large dust bag capacity

**Standard Equipment:** Floor Nozzle, Corner Nozzle, Straight Pipe, Bent Pipe, Hose (38mm), Hose (28mm), Front Cuffs (22, 24, 28), Plastic Dust Bag, Plastic Dust Bag x10, Cloth Filter, Damper, Dry Powder Filter, Tool Box, Connection Cord

- Z: Without Charger & Battery



<b>Capacity</b> Kapasiti 尘袋容量	Dust: 15L
<b>Max Air Flow</b> Aliran Udara 最大空气流量	AC: 3.6m³/min   DC: 2.1m³/min
<b>Max Sealed Suction</b> Sedutan Terkedap 最大密封吸力	AC: 24kPa   DC: 9kPa
<b>Suction Power</b> Kuasa Sedutan 吸力	AC: 320W   DC: 25 - 70W
<b>Dimensions (L x W x H)</b> Dimensi 体积	366x334x421mm (14-3/8"x13-1/8"x16-1/2")
<b>Net Weight</b> Berat Bersih 净重	9.6 - 10.3kg (21.2 - 22.6lbs.)
<b>Continuous Usage Time (approx.)</b> Masa Penggunaan Berterusan 连续使用时间	65 min with BL1850B x2

**DVC152LZ**  
RM 4,843

**Cordless Vacuum Cleaner (Wet & Dry)**  
Pembersih Vakum Tanpa Kord (Basah dan Kering)  
充电式吸尘器(干湿两用)



**WET**  
Basah 湿  
**DRY**  
Kering 干

- For both wet and dry vacuum cleaning

**Standard Equipment:** Floor Nozzle, Corner Nozzle, Straight Pipe, Bent Pipe, Hose (38mm), Plastic Dust Bag, Plastic Dust Bag x10, Cloth Filter, Tool Box

- Z: Without Charger & Battery



<b>Capacity</b> Kapasiti 尘袋容量	Dust: 15L   Water: 12L
<b>Max Air Flow</b> Aliran Udara 最大空气流量	2.1m³/min
<b>Max Sealed Suction</b> Sedutan Terkedap 最大密封吸力	9.8kPa
<b>Suction Power</b> Kuasa Sedutan 吸力	90W
<b>Dimensions (L x W x H)</b> Dimensi 体积	366x334x421mm (14-3/8"x13-1/8"x16-1/2")
<b>Net Weight</b> Berat Bersih 净重	7.3 - 7.9kg (16.0 - 17.4lbs.)
<b>Continuous Usage Time (approx.)</b> Masa Penggunaan Berterusan 连续使用时间	40 min with BL1850B x2

**DVC153LZ**  
RM 5,665

**Cordless Vacuum Cleaner (Dry)**  
Pembersih Vakum Tanpa Kord (Kering)  
充电式吸尘器(干用)



**DRY**  
Kering 干

- 15L Large dust bag capacity

**Standard Equipment:** Floor Nozzle, Corner Nozzle, Straight Pipe, Bent Pipe, Hose (38mm), Hose (28mm), Front Cuffs (22, 24, 28), Plastic Dust Bag, Plastic Dust Bag x10, Cloth Filter, Damper, Dry Powder Filter

- Z: Without Charger & Battery



<b>Capacity</b> Kapasiti 尘袋容量	Dust: 15L
<b>Max Air Flow</b> Aliran Udara 最大空气流量	2.1m³/min
<b>Max Sealed Suction</b> Sedutan Terkedap 最大密封吸力	9.8kPa
<b>Suction Power</b> Kuasa Sedutan 吸力	90W
<b>Dimensions (L x W x H)</b> Dimensi 体积	366x334x421mm (14-3/8"x13-1/8"x16-1/2")
<b>Net Weight</b> Berat Bersih 净重	8.0 - 8.6kg (17.6 - 19.0lbs.)
<b>Continuous Usage Time (approx.)</b> Masa Penggunaan Berterusan 连续使用时间	40 min with BL1850B x2

\* All list price shown are for reference only (exclude SST).

\* Semua harga yang ditunjukkan adalah untuk rujukan sahaja (tidak termasuk SST). 所有显示的建议零售价仅供参考 (不包括SST)。

Cordless  
Tanpa Kord 无线式

LED Flashlight  
Lampu Suka LED  
LED 闪光灯

Vacuum Cleaner  
Pembersih Vakum  
吸尘器

Drilling / Fastening  
Garu / Pengikat  
钻孔 / 紧固

Impact Drilling / Demolition  
Garu / Penorek  
打桩机 / 砸墙机

Cutting  
Pemotong  
切割

Grinding / Sanding  
Pijil / Pasir  
打磨 / 磨

Sawing  
Gergaji  
锯切

Planing / Routing  
Pijil / Tonggolan  
刨 / 压板

Others  
Lain-lain  
其他

Outdoor Power Equipment  
Alatan Kuasa Luar  
园机/户外





Li-ion Ah 6.0 5.0 4.0 3.0 2.0 1.5

Cordless  
Tanpa Kord / 无线

LED Flashlight  
Lampu Senter LED  
LED 手电筒

Vacuum Cleaner  
Pembersih Vakum  
吸尘器

Drilling / Fastening  
Dremel / Pengikat  
钻头 / 螺帽

Impact Drilling / Demolition  
Dremel / Perusak  
钻头 / 砸墙加工

Cutting  
Pemotongan  
切割

Grinding / Sanding  
Pengam / Pasir  
研磨 / 打磨

Sawing  
Cangkir  
切割

Planing / Routing  
Pengam / Rutekan  
刨削 / 雕刻

Others  
Lain-lain  
其他

Outdoor Power Equipment  
Alat-alat Listrik  
户外电力设备

Makita  
Makita

**DVC154LZ | DVC154LZX**  
RM 7,365 | RM 6,508

**Cordless Vacuum Cleaner (Dry)**  
Pembersih Vakum Tanpa Kord (Kering)  
充电式吸尘器(干用)



- Auto-Start Wireless System (AWS) Connects to Power Tool with Bluetooth

**Standard Equipment:**

DVC154LZ: Floor Nozzle, Corner Nozzle, Straight Pipe, Bent Pipe, Hose (38mm-2.5m), Plastic Dust Bag, Plastic Dust Bag x10, Cloth Filter, Front Cuffs, Dry Powder Filter, Damper  
DVC154LZX: Hose (38mm-2.5m), Plastic Dust Bag, Plastic Dust Bag x10, Cloth Filter, Front Cuffs, Dry Powder Filter, Damper

- Z / ZX: Without Charger & Battery



<b>Capacity</b> Kapasiti 尘袋容量	<b>Dust:</b> 15L
<b>Max Air Flow</b> Aliran Udara 最大空气流量	2.1m <sup>3</sup> /min
<b>Max Sealed Suction</b> Sedutan Terkedap 最大密封吸力	9.8kPa
<b>Suction Power</b> Kuasa Sedutan 吸力	90W
<b>Dimensions (L x W x H)</b> Dimensi 体积	366x334x421mm (14-3/8"x13-1/8"x16-1/2")
<b>Net Weight</b> Berat Bersih 净重	8.0 - 8.6kg (17.6 - 19.0lbs.)
<b>Continuous Usage Time (approx.)</b> Masa Penggunaan Berterusan 连续使用时间	40 min with BL1850B x2

**DVC155LZX3**  
Price TBA

**Cordless Vacuum Cleaner (Wet & Dry)**  
Pembersih Vakum Tanpa Kord (Basah dan Kering)  
充电式吸尘器(干湿两用)



- More Powerful Suction Power

**Standard Equipment:** Floor Nozzle, Long Sash Nozzle, Telescopic pipe assembly, Bent Pipe, Pipe, Hose, Plastic Dust Bag x10, Filter, Tool Box

- ZX3: Without Charger & Battery



<b>Capacity</b> Kapasiti 尘袋容量	<b>Dust:</b> 15L   <b>Water:</b> 12L
<b>Max Air Flow</b> Aliran Udara 最大空气流量	2.1m <sup>3</sup> /min
<b>Max Sealed Suction</b> Sedutan Terkedap 最大密封吸力	11kPa
<b>Suction Power</b> Kuasa Sedutan 吸力	105W
<b>Dimensions (L x W x H)</b> Dimensi 体积	366x334x421mm (14-3/8"x13-1/8"x16-1/2")
<b>Net Weight</b> Berat Bersih 净重	7.2 - 7.9kg (15.9 - 17.4lbs.)
<b>Continuous Usage Time (approx.)</b> Masa Penggunaan Berterusan 连续使用时间	83 min with BL1850B x2

**DVC157LZX5**  
Price TBA

**Cordless Vacuum Cleaner (Dry)**  
Pembersih Vakum Tanpa Kord (Kering)  
充电式吸尘器(干用)



- Auto-start Wireless System (AWS) connects to power tool with Bluetooth

**Standard Equipment:** Floor Nozzle, Corner Nozzle, Straight Pipe, Bent Pipe, Hose (38mm-2.5m), Plastic Dust Bag, Plastic Dust Bag x10, Cloth Filter, Tool Box, Damper, Dry Powder Filter

- ZX5: Without Charger & Battery



<b>Capacity</b> Kapasiti 尘袋容量	<b>Dust:</b> 15L
<b>Max Air Flow</b> Aliran Udara 最大空气流量	2.4m <sup>3</sup> /min
<b>Max Sealed Suction</b> Sedutan Terkedap 最大密封吸力	11kPa
<b>Suction Power</b> Kuasa Sedutan 吸力	110W
<b>Dimensions (L x W x H)</b> Dimensi 体积	366x334x421mm (14-3/8"x13-1/8"x16-1/2")
<b>Net Weight</b> Berat Bersih 净重	8.0 - 8.6kg (17.6 - 19.0lbs.)
<b>Continuous Usage Time (approx.)</b> Masa Penggunaan Berterusan 连续使用时间	83 min with BL1850B x2

**DVC864LZ**  
RM 4,878

**Cordless Vacuum Cleaner (Dry)**  
Pembersih Vakum Tanpa Kord (Kering)  
充电式吸尘器(干用)



- Auto-Start Wireless System (AWS) Connects to Power Tool with Bluetooth

**Standard Equipment:** Floor Nozzle, Corner Nozzle, Straight Pipe, Bent Pipe, Hose (38mm), Hose (28mm), Front Cuffs (22, 24, 28), Plastic Dust Bag, Plastic Dust Bag x10, Cloth Filter, Tool Box

- Z: Without Charger & Battery



<b>Capacity</b> Kapasiti 尘袋容量	<b>Dust:</b> 8L
<b>Max Air Flow</b> Aliran Udara 最大空气流量	2.1m <sup>3</sup> /min
<b>Max Sealed Suction</b> Sedutan Terkedap 最大密封吸力	9.8kPa
<b>Suction Power</b> Kuasa Sedutan 吸力	90W
<b>Dimensions (L x W x H)</b> Dimensi 体积	366x334x368 mm (14-3/8"x13-1/8"x14-1/2")
<b>Net Weight</b> Berat Bersih 净重	7.7 - 8.4 kg (17.1 - 18.4 lbs.)
<b>Continuous Usage Time (approx.)</b> Masa Penggunaan Berterusan 连续使用时间	40 min with BL1850B x2

**DVC860LZ**  
RM 4,607

**Cordless Vacuum Cleaner (Wet & Dry)**  
Pembersih Vakum Kuasa Elektrik Dan Tanpa Kord (Basah dan Kering)  
充电式 + 电源驱动吸尘器(干湿两用)



- Cloth filter type: for both wet & dry vacuum cleaning

**Standard Equipment:**

Floor Nozzle, Corner Nozzle, Straight Pipe, Bent Pipe, Hose (38mm), Plastic Dust Bag, Plastic Dust Bag x10, Cloth Filter, Tool Box, Connection Cord

- Z: Without Charger & Battery

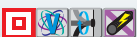

**VIDEO CLIP**  
Models and specs may vary by country  
DVC860/DCL500



<b>Capacity</b> Kapasiti 尘袋容量	<b>Dust:</b> 8L <b>Water:</b> 6L
<b>Max Air Flow</b> Aliran Udara 最大空气流量	<b>AC:</b> 3.6m <sup>3</sup> /min <b>DC:</b> 2.1m <sup>3</sup> /min
<b>Max Sealed Suction</b> Sedutan Terkedap 最大密封吸力	<b>AC:</b> 24kPa <b>DC:</b> 9kPa
<b>Suction Power</b> Kuasa Sedutan 吸力	<b>AC:</b> 320W <b>DC:</b> 25 - 70W
<b>Dimensions (L x W x H)</b> Dimensi 体积	366x334x368mm (14-3/8"x13-1/8"x14-1/2")
<b>Net Weight</b> Berat Bersih 净重	8.6kg (19.0lbs.)
<b>Continuous Usage Time (approx.)</b> Masa Penggunaan Berterusan 连续使用时间	65 min with BL1850B x2

\* All list price shown are for reference only (exclude SST).

\* Semua harga yang ditunjukkan adalah untuk rujukan sahaja (tidak termasuk SST). 所有显示的建议零售价仅供参考 (不包括SST)。



Li-ion Ah 6.0 5.0 4.0 3.0 2.0 1.5

**DVC862LPT2** RM 5,307 | **DVC862LRT2** RM 5,007 | **DVC862LZ** RM 3,720

**Cordless Vacuum Cleaner (Wet & Dry)**  
Pembersih Vakum Tanpa Kord  
(Basah dan Kering)  
充电式吸尘器(干湿两用)



• For both wet and dry vacuum cleaning

**Standard Equipment:** Floor Nozzle, Corner Nozzle, Straight Pipe, Bent Pipe, Hose (38mm), Plastic Dust Bag, Plastic Dust Bag x10, Cloth Filter, Tool Box

- PT2: 1x Two Port Multi Fast Charger, 2x 5.0Ah Battery
- RT2: 1x Rapid Charger, 2x 5.0Ah Battery
- Z: Without Charger & Battery



<b>Capacity</b> Kapasiti 尘袋容量	Dust: 8L
<b>Max Air Flow</b> Aliran Udara 最大空气流量	Water: 6L 2.1m³/min
<b>Max Sealed Suction</b> Sedutan Terkedap 最大密封吸力	9.8kPa
<b>Suction Power</b> Kuasa Sedutan 吸力	90W
<b>Dimensions (L x W x H)</b> Dimensi 体积	366x334x368mm (14-3/8"x13-1/8"x14-1/2")
<b>Net Weight</b> Berat Bersih 净重	7.0kg (15.5lbs.)
<b>Continuous Usage Time (approx.)</b> Masa Penggunaan Berterusan 连续使用时间	40 min with BL1850B x2

**DVC863LPT2** RM 5,918 | **DVC863LRT2** RM 5,618 | **DVC863LZ** RM 4,333

**Cordless Vacuum Cleaner (Dry)**  
Pembersih Vakum Tanpa Kord (Kering)  
充电式吸尘器(干用)



• 8L Large dust bag capacity enables continuous cleaning work

**Standard Equipment:** Floor Nozzle, Corner Nozzle, Straight Pipe, Bent Pipe, Hose (38mm), Hose (28mm), Front Cuffs (22, 24, 38), Plastic Dust Bag, Plastic Dust Bag x10, Cloth Filter, Tool Box

- PT2: 1x Two Port Multi Fast Charger, 2x 5.0Ah Battery
- RT2: 1x Rapid Charger, 2x 5.0Ah Battery
- Z: Without Charger & Battery



<b>Capacity</b> Kapasiti 尘袋容量	Dust: 8L
<b>Max Air Flow</b> Aliran Udara 最大空气流量	2.1m³/min
<b>Max Sealed Suction</b> Sedutan Terkedap 最大密封吸力	9.8kPa
<b>Suction Power</b> Kuasa Sedutan 吸力	90W
<b>Dimensions (L x W x H)</b> Dimensi 体积	366x334x368mm (14-3/8"x13-1/8"x14-1/2")
<b>Net Weight</b> Berat Bersih 净重	7.7kg (17.1lbs.)
<b>Continuous Usage Time (approx.)</b> Masa Penggunaan Berterusan 连续使用时间	40 min with BL1850B x2

**DVC265ZX**  
RM 3,343

**Cordless Backpack Vacuum Cleaner**  
Pembersih Vakum Beg Galas Tanpa Kord  
充电式背负吸尘器



• Increased suction power for improved dust collection

**Standard Equipment:** Hose, Hose Band, Dust Bag, Front Cuffs (22, 24)

- Z: Without Charger & Battery



<b>Capacity</b> Kapasiti 尘袋容量	Paper Dust Bag: 2.0L Cloth Dust Bag: 1.5L
<b>Max Air Flow</b> Aliran Udara 最大空气流量	w/ Hose Complete 28-1.0: 2.0m³/min w/ Hose Complete 28-1.5: 1.8m³/min
<b>Max Sealed Suction</b> Sedutan Terkedap 最大密封吸力	11kPa
<b>Suction Power</b> Kuasa Sedutan 吸力	w/ Hose 28-1.0: High: 90W   Normal: 45W w/ Hose 28-1.5: High: 85W   Normal: 45W
<b>Dimensions (L x W x H)</b> Dimensi 体积	230x152x373mm (9"x6"x14-3/4")
<b>Net Weight</b> Berat Bersih 净重	3.9 - 4.5kg (8.6 - 10.0lbs.)
<b>Continuous Usage Time (approx.)</b> Masa Penggunaan Berterusan 连续使用时间	High: 33 min   Low: 62 min with BL1850B x2

**DVC261Z**  
RM 2,577

**Cordless Backpack Vacuum Cleaner**  
Pembersih Vakum Beg Galas Tanpa Kord  
充电式背负吸尘器

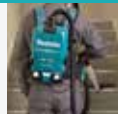

• Increased Suction Power for Improved Dust Collection

**Standard Equipment:** HEPA Filter Assembly, Hose Band, Paper Filter Bag (2L), Hose (28mm), Floor Nozzle, Flexible Rubber Nozzle, Telescopic Pipe Assembly, Bent Pipe

- Z: Without Charger & Battery



<b>Capacity</b> Kapasiti 容量	Paper Dust Bag: 2.0L Cloth Dust Bag: 1.5L
<b>Max Air Flow</b> Aliran Udara 最大空气流量	w/ Hose complete 38-1.5: 2.3 m³/min w/ Hose Complete 32-1.0: 2.2 m³/min w/ Hose Complete 28-1.0: 2.0 m³/min w/ Hose Complete 28-1.5: 1.8 m³/min
<b>Max Sealed Suction</b> Sedutan Terkedap 最大密封吸力	11 kPa
<b>Suction Power</b> Kuasa Sedutan 吸力	Max/ High/ Normal w/ Hose 38-1.5: 105/ 55/ 30W Max/ High/ Normal w/ Hose 32-1.0: 95/ 50/ 25W Max/ High/ Normal w/ Hose 28-1.0: 90/ 45/ 25W Max/ High/ Normal w/ Hose 28-1.5: 85/ 45/ 25W
<b>Dimensions (L x W x H)</b> Dimensi 体积	230x152x373mm (9"x6"x14-3/4")
<b>Net Weight</b> Berat Bersih 净重	3.8 - 4.5kg (8.5 - 9.9lbs.)
<b>Continuous Usage Time (approx.)</b> Masa Penggunaan Berterusan 连续使用时间	Normal: 115 min   High: 63 min   Max: 33 min with BL1850B x2

**DVC260Z** RM 2,078 | **DVC260ZX** RM 2,078

**Cordless Backpack Vacuum Cleaner**  
Pembersih Vakum Beg Galas Tanpa Kord  
充电式背负吸尘器



• Max suction power 45W

**Standard Equipment:**  
DVC260Z: HEPA Filter Assembly, Backpack Shoulder Harness, Hose Band, Paper Filter Bag (2L), Hose 28mm (1.0M), Floor Nozzle, Flexible Rubber Nozzle, Telescopic Pipe Assembly, Bent Pipe  
DVC260ZX: HEPA Filter Assembly, Backpack Shoulder Harness, Hose Band, Paper Filter Bag (2L), Hose 28mm (1.5M), Front Cuffs (22, 24)

- Z / ZX: Without Charger & Battery



DVC260

Models and specs may vary by country



<b>Capacity</b> Kapasiti 容量	Filter bag / Paper dust bag: 2.0L Cloth dust bag: 1.5L
<b>Max Air Flow</b> Aliran Udara 最大空气流量	1.5m³/min
<b>Max Sealed Suction</b> Sedutan Terkedap 最大密封吸力	7.1kPa (710mmH <sub>2</sub> O)
<b>Suction Power</b> Kuasa Sedutan 吸力	High: 45W   Low: 25W
<b>Dimensions (L x W x H)</b> Dimensi 体积	230x152x373mm (9"x6"x14-3/4")
<b>Net Weight</b> Berat Bersih 净重	3.8kg (8.5 lbs)
<b>Continuous Usage Time (approx.)</b> Masa Penggunaan Berterusan 连续使用时间	Low: 90 min   High: 60 min with BL1850B x2

\* All list price shown are for reference only (exclude SST).

\* Semua harga yang ditunjukkan adalah untuk rujukan sahaja (tidak termasuk SST). 所有显示的建议零售价仅供参考 (不包括SST)。

Cordless  
Tanpa Kord 无线

LED Flashlight  
Lampu Suluh LED  
LED照明灯

Vacuum Cleaner  
Pembersih Vakum  
吸尘器

Drilling / Fastening  
Garu / Pengikat  
钻孔 / 紧固

Impact Drilling / Demolition  
Garu / Penorek  
打桩机 / 拆墙机

Cutting  
Pemotong  
切割

Grinding / Sanding  
Pengiraian / Palsan  
打磨 / 磨平

Sawing  
Gergaji  
锯切

Planing / Routing  
Pengiraian / Tunggam  
刨平 / 雕刻

Others  
Lain-lain  
其他

Outdoor Power Equipment  
Alatan Kertam Luar  
园具/户外

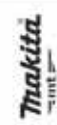



Li-ion Ah 6.0 5.0 4.0 3.0 2.0 1.5

# Cordless Backpack Vacuum Cleaner

Pembersih Vakum Beg Galas Tanpa Kord 充电式背负吸尘机

**DVC660**

**DVC665**



**Dust Capacity**  
Kapasiti Habuk 集尘容量

**6L**

with paper dust bag

**Max Sealed Suction**  
Sedutan Terkedap (Turus Air)  
最大密封吸力(水柱)

**11 kPa**

## HEPA filter

HEPA Filter is used as the main filter to capture very fine particles effectively  
Penapis HEPA digunakan sebagai penapis utama, yang dapat menangkap zarah-zarah yang sangat halus  
HEPA过滤器用作主要过滤器, 可有效捕获非常细的颗粒

**Able to capture 99.97% of particles as small as 0.3-1µm**

Mampu menangkap 99.97% zarah sekecil 0.3-1µm  
99.97% 能够捕获小至0.3-1µm的颗粒



## Cleaning mechanism for paper dust bag

Mekanisme pembersih beg habuk kertas 纸尘袋的清洁机制



This mechanism can be actuated:

- Automatically by the vibration due to walking
- Manually by operating a lever by hand
- Secara automatik oleh getaran kerana berjalan
- Secara manual dengan mengoperasikan tuas dengan tangan
- 行走时自动振动 · 手动操纵杆

### DVC660Z

RM 3,118

#### Cordless Backpack Vacuum Cleaner

Pembersih Vakum Beg Galas Tanpa Kord  
充电式背负吸尘机

- Increased suction power for improved dust collection

Standard Equipment: Floor Nozzle, Hose, Hose Band, Nozzle Assembly, Telescopic Pipe Assembly, Bent Pipe, Free Nozzle, Dust Bag

- Z: Without Charger & Battery



#### Capacity

Kapasiti 尘袋容量

Paper Dust Bag: 6.0L

Cloth Dust Bag: 5.5L

Max Air Flow

Aliran Udara 最大空气流量

Max Sealed Suction

Sedutan Terkedap 最大密封吸力

Suction Power

Kuasa Sedutan 吸力

Dimensions (L x W x H)

Dimensi 体积

Net Weight

Berat Bersih 净重

Continuous Usage Time (approx.)

Masa Penggunaan Berterusan 连续使用时间

Paper Dust Bag: 6.0L

Cloth Dust Bag: 5.5L

w/ Hose complete 32-1.0: 2.2m<sup>3</sup>/min

w/ Hose Complete 28-1.0: 2.0m<sup>3</sup>/min

11kPa

Max: 90W | High: 45W | Normal: 25W

297x174x523mm

(11-3/4"x6-7/8"x20-5/8")

6.1 - 6.7kg (13.4 - 14.8lbs.)

Max: 33 min | High: 62 min |

Normal: 116 min with BL1850B x2

### DVC665Z

RM 3,773

#### Cordless Backpack Vacuum Cleaner

Pembersih Vakum Beg Galas Tanpa Kord  
充电式背负吸尘机

- Increased suction power for improved dust collection

Standard Equipment: Hose Band, Filter Bag, Hose 28-1.5, Front Cuffs (22, 24)

- Z: Without Charger & Battery



#### Capacity

Kapasiti 尘袋容量

Paper Dust Bag: 6.0L

Cloth Dust Bag: 5.5L

Max Air Flow

Aliran Udara 最大空气流量

Max Sealed Suction

Sedutan Terkedap 最大密封吸力

Suction Power

Kuasa Sedutan 吸力

Dimensions (L x W x H)

Dimensi 体积

Net Weight

Berat Bersih 净重

Continuous Usage Time (approx.)

Masa Penggunaan Berterusan 连续使用时间

Paper Dust Bag: 6.0L

Cloth Dust Bag: 5.5L

w/ Hose Complete 28-1.5: 1.8 m<sup>3</sup>/min

11kPa

High: 85W | Normal: 45W

With Hose 28-1.5

297x174x523mm

(11-3/4"x6-7/8"x20-5/8")

6.1 - 6.7kg (13.5 - 14.9lbs.)

High: 33 min | Normal: 62 min |

with BL1850B x2

\* All list price shown are for reference only (exclude SST).

\* Semua harga yang ditunjukkan adalah untuk rujukan sahaja (tidak termasuk SST). 所有显示的建议零售价仅供参考 (不包括SST)。

Cordless  
Tanpa Kord 无线式

LED Flashlight  
Lampu Suka LED  
LED 手电筒

Vacuum Cleaner  
Pembersih Vakum  
吸尘器

Drilling | Fastening  
Draht | Pengikat  
钻孔 | 紧固

Impact Drilling | Demolition  
Draht | Pencah  
冲击钻孔 | 拆除加工

Cutting  
Pemotongan  
切割

Grinding | Sanding  
Pengamiran | Polesan  
打磨 | 砂磨

Sawing  
Dempul  
切割

Planing | Routing  
Pengamiran | Tengking  
刨削 | 雕刻

Others  
Lain-lain  
其他

Outdoor Power Equipment  
Alatan Kuasa Luar  
户外动力设备



18V

LXT

Li-ion Ah 6.0 5.0 4.0 3.0 2.0 1.5

# Robotic Cleaner

Pembersih Robotik 充电式智能吸尘器

**Able to clean surface area of 500m<sup>2</sup>** with BL1850B x2  
 Boleh membersihkan kawasan permukaan Seluas 500m<sup>2</sup> dengan BL1850B x2  
 使用2粒BL1850B型电池的可清洁500m<sup>2</sup>的面积



**Large Capacity**  
 Kapasiti besar 最大容量  
**2.5L**

\*Masa Penggunaan Berterusan  
 连续使用时间  
**Continuous Usage Time**  
 with BL1850B x2  
 (Normal Speed)  
**200min**  
 (approx.)

## Selectable two dust collection modes

Pemilihan dua mod koleksi habuk 可选择两种集尘模式

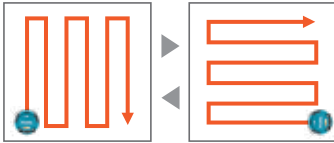

### Pattern cleaning mode

Mod pembersihan corak 规则清理模式

For cleaning wide spaces with few obstacles. (Ex.) well-organized warehouses, long corridors, etc.  
 Untuk membersihkan ruang yang luas dengan beberapa halangan. (contoh) gudang yang teratur, koridor panjang, dan lain-lain.  
 适用于清洁较宽的空间和障碍物少的场所 (例如: 摆放规则的仓库, 太长的走廊等)

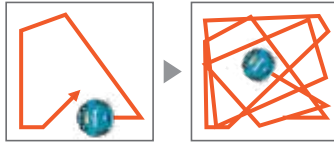

### Random cleaning mode

Mod pembersihan secara rawak 随机清洗模式

For cleaning locations with many obstacles. (Ex.) offices, etc.  
 Untuk membersihkan lokasi dengan banyak halangan. (contoh) Pejabat, dan lain-lain.  
 适用于清洁障碍物较多的场所 (例如: 办公室等)



## DRC200Z

RM 11,285

**Robotic Cleaner**  
 Pembersih Robotik  
 充电式智能吸尘器



• Able to clean an area of 300m<sup>2</sup> per 120 min with a coverage rate of 80%

Standard Equipment: Wireless remote controller (including two AAA alkaline batteries), Side Brush, Boundary Tape

• Z: Without Charger & Battery



<b>Max Cleaning Area</b> Kawasan Pembersihan Maksimum 最大清洁面积	BL1850B x2 : 500m <sup>2</sup>
<b>Max Running Speed</b> Kelajuan Operasi Maksimum 最大运行速度	0.3m/ sec
<b>Dust Box Capacity</b> Kapasiti 容量	2.5L
<b>Dimensions (L x W x H)</b> Dimensi 体积	460x460x180mm (18-1/8"x18-1/8"x7-1/8")
<b>Net Weight</b> Berat Bersih 淨重	7.3kg (16.1lbs)
<b>Continuous Usage Time (approx.)</b> Masa Penggunaan Berterusan 连续使用时间	200 min with BL1850B x2

## DCL501Z

RM 2,528

**Cordless Cyclone Cleaner**  
 Pembersih Vakum Cyclone  
 Tanpa Kord  
 充电式旋风吸尘器



• Quiet operation for operator comfort

Standard Equipment: Shoulder Belt, Crevice Nozzle, Cleaning Brush, Floor Nozzle, Zoom Pipe, Hose, Hose Hook

• Z: Without Charger & Battery



<b>Capacity</b> Kapasiti 容量	250mL
<b>Max Air Flow</b> Aliran Udara 最大空气流量	1.2m <sup>3</sup> /min
<b>Max Sealed Suction (water column)</b> Sedutan Terkedap (Turus Air) 最大密封吸力(水柱)	10kPa (1,020mmH <sub>2</sub> O)
<b>Suction Power</b> Kuasa Sedutan 吸力	High: 75W   Low: 25W
<b>Dimensions (L x W x H)</b> Dimensi 体积	352x189x252mm (13-7/8"x7-7/16"x9-7/8")
<b>Net Weight</b> Berat Bersih 淨重	3.1kg (6.8 lbs.)
<b>Continuous Usage Time (approx.)</b> Masa Penggunaan Berterusan 连续使用时间	Low: 64 min   High: 29 min with BL1850B

## DCL500Z

RM 1,970

**Cordless Cyclone Cleaner**  
 Pembersih Vakum Cyclone  
 Tanpa Kord  
 充电式旋风吸尘器

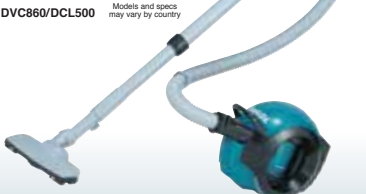

• HEPA Clean Filter offers maximum performance for residential and commercial applications

Standard Equipment: Shoulder Belt, Crevice Nozzle, Floor Nozzle, Zoom Pipe, Hose, Hose Hook

• Z: Without Charger & Battery



<b>Capacity</b> Kapasiti 容量	250mL
<b>Max Air Flow</b> Aliran Udara 最大空气流量	1.3m <sup>3</sup> /min
<b>Max Sealed Suction (water column)</b> Sedutan Terkedap (Turus Air) 最大密封吸力(水柱)	6.6kPa (660mmH <sub>2</sub> O)
<b>Suction Power</b> Kuasa Sedutan 吸力	High: 75W   Low: 25W
<b>Dimensions (L x W x H)</b> Dimensi 体积	352x189x252mm (13-7/8"x7-7/16"x9-7/8")
<b>Net Weight</b> Berat Bersih 淨重	3.6kg (7.9 lbs.)
<b>Continuous Usage Time (approx.)</b> Masa Penggunaan Berterusan 连续使用时间	Low: 50 min   High: 20 min with BL1850B

\* All list price shown are for reference only (exclude SST).

\* Semua harga yang ditunjukkan adalah untuk rujukan sahaja (tidak termasuk SST). 所有显示的建议零售价仅供参考 (不包括SST)。

Cordless  
Tapis Kord 无线

LED Flashlight  
Lampu Suka LED  
LED照明灯

Vacuum Cleaner  
Pembersih Vakum  
吸尘器

Drilling / Fastening  
Gergaji / Pengikat  
钻孔 / 紧固

Impact Drilling / Demolition  
Gergaji / Penunjuk  
打桩机 / 拆墙机

Cutting  
Pemotong  
切割

Grinding / Sanding  
Pengkilan / Palsan  
打磨 / 磨漆

Sanding  
Gergaji  
磨漆

Planing / Routing  
Pengkilan / Tunggam  
刨板 / 刨花

Others  
Lain-lain  
其他

Outdoor Power Equipment  
Alatan Kuasa Luar  
户外动力工具



Cordless  
Tangan Keras  
LED Flashlight  
Lampu Senter LED  
Vacuum Cleaner  
Penyedot Debu  
Drilling / Fastening  
Droptail / Pengikat  
Impact Drilling / Demolition  
Droptail / Pemecah  
Cutting / Pemotongan  
Grinding / Sanding  
Pengamir / Pasikan  
Sawing  
Dengki  
Planing / Routing  
Pengamir / Tanggapan  
Others  
Lain-lain  
Outdoor Power Equipment  
Alatan Keras Luar  
Makita

## CAPSULE TYPE

Jenis Kapsul 胶囊型



**No need to use paper bag.**  
This is a cost saving for repeated use

Tidak perlu menggunakan beg debu kertas, boleh digunakan semula untuk menjimatkan kos. 无需纸集尘袋, 可重复使用以节省成本。



**Filter** Penapis 过滤器  
**Pre Filter** Penapis Depan 前置过滤器

## TRIGGER SWITCH

Suis Pemicu 扳机开关



**Ergonomic Handle With Easy On/ Off Trigger Switch**

Pemegang ergonomik dengan suis pemicu hidup/ mati mudah. 符合人体工程学的手柄, 扳机开关。



**Easy shake off dust filter**  
**High Performance Filter**  
Penapis prestasi tinggi 高效过滤器

**Easy shake off filter B set**

**HEPA filter**  
**Filter H set**

For all LXT & CXT range using capsule type (18V & 12Vmax only)



### DCL280

Suction Power  
Kuasa Sedutan 吸力

**45w**

Large Capacity  
Kapasiti Besar 最大容量

**750mL**

Net Weight  
Berat Bersih 净重

**1.2kg**



Lock on button



### DCL180

Suction Power  
Kuasa Sedutan 吸力

**30w**

Large Capacity  
Kapasiti Besar 最大容量

**650mL**

Net Weight  
Berat Bersih 净重

**1.2kg**

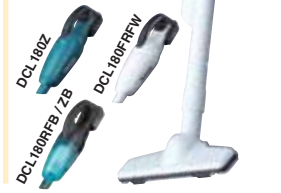

## CAPSULE TYPE

Jenis Kapsul 胶囊型



**No need to use paper bag.**  
This is a cost saving for repeated use

Tidak perlu menggunakan beg debu kertas, boleh digunakan semula untuk menjimatkan kos. 无需纸集尘袋, 可重复使用以节省成本。



**Filter** Penapis 过滤器  
**Pre Filter** Penapis Depan 前置过滤器

## SWITCH BUTTON

Butang Suis 开关按钮



**Simply push a power on button for continuous use**

Hanya tekan butang kuasa untuk kegunaan berterusan. 一按式开关就能持续使用。



**Easy shake off dust filter**  
**High Performance Filter**  
Penapis prestasi tinggi 高效过滤器

**Easy shake off filter B set**

**HEPA filter**  
**Filter H set**

For all LXT & CXT range using capsule type (18V & 12Vmax only)



### DCL281F

Suction Power  
Kuasa Sedutan 吸力

**60w**

Large Capacity  
Kapasiti Besar 最大容量

**750mL**

Net Weight  
Berat Bersih 净重

**1.2kg**



### DCL181F

Suction Power  
Kuasa Sedutan 吸力

**30w**

Large Capacity  
Kapasiti Besar 最大容量

**650mL**

Net Weight  
Berat Bersih 净重

**1.2kg**



## DUST BAG TYPE

Beg Debu Penapis 尘袋型



**Simply by open the front cover for easy dust bag change**

Hanya dengan membuka penutup depan untuk menukar beg habuk dengan mudah. 打开前盖, 简便更换尘袋。



**Paper Filter**  
Penapis Kertas 纸制尘袋



**Dust Bag**  
Beg habuk 集尘袋



**High Performance Dust Bag**  
Beg habuk prestasi tinggi 高效集尘袋

**Easy shake off dust bag**



**Simply push a power on button for continuous use**

Hanya tekan butang kuasa untuk kegunaan berterusan. 一按式开关就能持续使用。



### DCL182

Suction Power  
Kuasa Sedutan 吸力

**30w**

Large Capacity  
Kapasiti Besar 最大容量

**500mL**

Net Weight  
Berat Bersih 净重

**1.2kg**



\* All list price shown are for reference only (exclude SST).

\* Semua harga yang ditunjukkan adalah untuk rujukan sahaja (tidak termasuk SST). 所有显示的建议零售价仅供参考 (不包括SST)。



**CL106FD**

Suction Power  
Kuasa Sedutan 吸力

**19<sub>w</sub>**

Large Capacity  
Kapasiti Besar 最大容量

**600<sub>mL</sub>**

Net Weight  
Berat Bersih 淨重

**1.0<sub>kg</sub>**



**CL100D**

Suction Power  
Kuasa Sedutan 吸力

**14<sub>w</sub>**

Large Capacity  
Kapasiti Besar 最大容量

**600<sub>mL</sub>**

Net Weight  
Berat Bersih 淨重

**0.88<sub>kg</sub>**



BUILT-IN LITHIUM-ION BATTERY

**CL111D**

Suction Power  
Kuasa Sedutan 吸力

**21<sub>w</sub>**

Large Capacity  
Kapasiti Besar 最大容量

**560<sub>mL</sub>**

Net Weight  
Berat Bersih 淨重

**0.94<sub>kg</sub>**



**CL070D**

Suction Power  
Kuasa Sedutan 吸力

**14<sub>w</sub>**

Large Capacity  
Kapasiti Besar 最大容量

**600<sub>mL</sub>**

Net Weight  
Berat Bersih 淨重

**0.81<sub>kg</sub>**



Cordless  
Terdapat Bateri Binaan

LED Flashlight  
Lampu Suluhi LED  
LED 照灯

Vacuum Cleaner  
Pembersih Vakuum  
吸尘器

Drilling / Fastening  
Gergaji / Pengikat  
电钻 / 螺丝



**CL108FD**

Suction Power  
Kuasa Sedutan 吸力

**30<sub>w</sub>**

Large Capacity  
Kapasiti Besar 最大容量

**600<sub>mL</sub>**

Net Weight  
Berat Bersih 淨重

**1.0<sub>kg</sub>**



Impact Drilling / Demolition  
Gergaji / Penorek  
打洞器 / 拆墙器

Cutting  
Pemotong  
切割机

Grinding / Sanding  
Pengkilan / Palsan  
打磨 / 砂磨

Sawing  
Gergaji  
锯切



**CL107FD**

Suction Power  
Kuasa Sedutan 吸力

**32<sub>w</sub>**

Large Capacity  
Kapasiti Besar 最大容量

**500<sub>mL</sub>**

Net Weight  
Berat Bersih 淨重

**1.1<sub>kg</sub>**



**CL102D**

Suction Power  
Kuasa Sedutan 吸力

**14<sub>w</sub>**

Large Capacity  
Kapasiti Besar 最大容量

**500<sub>mL</sub>**

Net Weight  
Berat Bersih 淨重

**1.1<sub>kg</sub>**



BUILT-IN LITHIUM-ION BATTERY

**CL104D  
CL105D**

Suction Power  
Kuasa Sedutan 吸力

**20<sub>w</sub>**

Large Capacity  
Kapasiti Besar 最大容量

**500<sub>mL</sub>**

Net Weight  
Berat Bersih 淨重

**1.1<sub>kg</sub>**

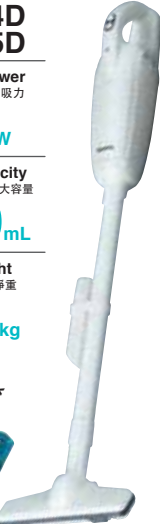

Planing / Routing  
Pengkilan / Tunggam  
刨板 / 磨板

Others  
Lain-lain  
其他

Outdoor Power Equipment  
Alatan Kuasa Luar  
园机 / 户外

\* All list price shown are for reference only (exclude SST).  
\* Semua harga yang ditunjukkan adalah untuk rujukan sahaja (tidak termasuk SST). 所有显示的建议零售价仅供参考 (不包括SST)。





# Cordless Cleaner

Pembersih Vakum Tanpa Kord 充电式便携吸尘器

Cordless  
Tanpa Kord 无线式

LED Flashlight  
Lampu Sualah LED  
LED 照明灯

Vacuum Cleaner  
Pembersih Vakum  
吸尘器

Drilling / Fastening  
Ganda / Pengikat  
钻孔 / 紧固

Impact Drilling / Demolition  
Ganda / Penembak  
冲击钻孔 / 拆除加工

Cutting  
Pemotong  
切割

Grinding / Sanding  
Pengam / Pasir  
打磨 / 砂磨

Sawing  
Gergaji  
锯切

Planing / Routing  
Pengam / Tuangam  
刨削 / 雕刻

Others  
Lain-lain  
其他

Outdoor Power Equipment  
Alatan Kuasa Luar  
园具 / 户外

Makita  
18V LXT

One touch push button switch

Suis butang tekan satu-sentuhan  
一键式按钮开关

LED job light  
Lampu kerja LED  
LED 工作灯

\*Masa Penggunaan Berterusan  
连续使用时间

**Continuous Usage Time with BL1830B (Normal Speed)**

**50min**  
(approx.)

\* Continuous Usage Time/Work Amount: Actual performance may vary based on application. Masa Penggunaan Berterusan/ Jumlah Kerja: Prestasi sebenar mungkin berbeza mengikut aplikasi. 连续使用时间/工作量: 实际使用量可能因应用而异。

Dust Capacity  
Kapasiti Habuk 集尘容量

**750mL**

Suction Power  
Kuasa Sedutan 吸力

**Max: 60w**

**Pipe lock**  
Pipe is fixed with the locking mechanism to prevent it from accidentally coming off  
Paip dengan mekanisme pengunci untuk mengelakkan ketanggalan yang tidak disengajakan  
管道通过锁定机构固定，以防止其意外脱落

**New internal construction prevents loose installation of filter/ paper dust bag to protect the motor room from dust**

Melindungi motor dari habuk dengan struktur dalaman baru yang mengelakkan kelonggaran pemasangan beg debu dan penapis kertas  
新的内部结构可防止过滤器/纸尘袋松动安装，以保护机房免受灰尘影响

**HEPA filter is available (Optional Accessories)**

**HEPA filter**

Pre-filter or Easy shake off filter B set + HEPA filter

<b>DCL281FZW</b> RM 823	<b>DCL281FZB</b> RM 823	<b>DCL281FZ</b> RM 823
----------------------------	----------------------------	---------------------------

**Cordless Cleaner**  
Pembersih Vakum Tanpa Kord  
充电式便携吸尘器

**Standard Equipment:** Floor Nozzle, Sash Nozzle, Sash Nozzle Holder, Pipe, Stay

- ZW: Without Charger & Battery (White)
- ZB: Without Charger & Battery (Black)
- Z: Without Charger & Battery (Blue)

**BL MOTOR**

<b>Capacity</b> Kapasiti 容量	750mL
<b>Max Air Flow</b> Aliran Udara 最大空气流量	1.5m³/min
<b>Max Sealed Suction (water column)</b> Sedutan Terkedap (Turus Air) 最大密封吸力(水柱)	8.2kPa (820mmH <sub>2</sub> O)
<b>Suction Power</b> Kuasa Sedutan 吸力	Max: 60W   High: 45W   Normal: 15W with Normal Filter Max: 55W   High: 40W   Normal: 13W with Easy Shake Off Filter
<b>Dimensions (L x W x H)</b> Dimensi 体积	1,016x113x154mm (40"x4-7/16"x6-1/6")
<b>Net Weight</b> Berat Bersih 淨重	1.2 - 1.6kg (2.7 - 3.5lbs.)
<b>Continuous Usage Time (approx.)</b> Masa Penggunaan Berterusan 连续使用时间	Max: 25 min   High: 33 min   Normal: 83 min with BL1850B

<b>DCL280FZW</b> RM 700	<b>DCL280FZB</b> RM 700	<b>DCL280FZ</b> RM 700
----------------------------	----------------------------	---------------------------

**Cordless Cleaner**  
Pembersih Vakum Tanpa Kord  
充电式便携吸尘器

**Standard Equipment:** Floor Nozzle, Sash Nozzle, Sash Nozzle Holder, Pipe, Prefilter, Filter H Set (HEPA Filter)

- ZW: Without Charger & Battery (White)
- ZB: Without Charger & Battery (Black)
- Z: Without Charger & Battery (Blue)

**BL MOTOR**

**NEW BARU 新**

<b>Capacity</b> Kapasiti 容量	750mL
<b>Max Air Flow</b> Aliran Udara 最大空气流量	1.4m³/min
<b>Max Sealed Suction (water column)</b> Sedutan Terkedap (Turus Air) 最大密封吸力(水柱)	6.4kPa (640mmH <sub>2</sub> O)
<b>Suction Power</b> Kuasa Sedutan 吸力	Normal Filter: 45W Easy Shake Off Filter: 40W
<b>Dimensions (L x W x H)</b> Dimensi 体积	1,016x113x154mm (40"x4-7/16"x6-1/6")
<b>Net Weight</b> Berat Bersih 淨重	1.2 - 1.6kg (2.7 - 3.5lbs.)
<b>Continuous Usage Time (approx.)</b> Masa Penggunaan Berterusan 连续使用时间	33 min with BL1850B

\* All list price shown are for reference only (exclude SST).

\* Semua harga yang ditunjukkan adalah untuk rujukan sahaja (tidak termasuk SST). 所有显示的建议零售价仅供参考 (不包括SST)。





Li-ion Ah 6.0 5.0 4.0 3.0 2.0 1.5

### DCL181FZWX

RM 632

#### Cordless Cleaner

Pembersih Vakum Tanpa Kord  
充电式便携吸尘器



- Strong suction power for fast cleaning with more run time

**Standard Equipment:** Floor Nozzle, Sash Nozzle, Sash Nozzle Holder, Pipe, Filter, Prefilter, Stay

- ZWX: Without Charger & Battery (White)



<b>Capacity</b> Kapasiti 容量	650mL
<b>Max Air Flow</b> Aliran Udara 最大空气流量	1.4m <sup>3</sup> /min
<b>Max Sealed Suction (water column)</b> Sedutan Terkedap (Turus Air) 最大密封吸力(水柱)	5.3kPa (540mmH <sub>2</sub> O)
<b>Suction Power</b> Kuasa Sedutan 吸力	High: 30W   Low: 11W
<b>Dimensions (L x W x H)</b> Dimensi 体积	999x114x152mm (39-1/4"x4-1/2"x6")
<b>Net Weight</b> Berat Bersih 净重	1.2 - 1.4kg (2.7 - 3.1lbs.)
<b>Continuous Usage Time (approx.)</b> Masa Penggunaan Berterusan 连续使用时间	Low: 66 min   High: 33 min with BL1850B

### DCL180FRFW

RM 1,143

### DCL180RFB

RM 1,143

### DCL180ZB

RM 487

### DCL180Z

RM 487

#### Cordless Cleaner

Pembersih Vakum Tanpa Kord  
充电式便携吸尘器



- Strong suction power for fast cleaning

**Standard Equipment:**

FRFW: Floor Nozzle, Sash Nozzle, Sash Nozzle Holder, Pipe, Stay, Easy Shake Off Filter  
RFB / ZB / Z: Floor Nozzle, Sash Nozzle, Sash Nozzle Holder, Pipe, Stay, Filter, Prefilter

- FRFW: 1x Rapid Charger, 1x 3.0Ah Battery (White)
- RFB: 1x Rapid Charger, 1x 3.0Ah Battery (Black)
- ZB: Without Charger & Battery (Black)
- Z: Without Charger & Battery (Blue)

- Only for DCL180FRFW



<b>Capacity</b> Kapasiti 容量	650mL
<b>Max Air Flow</b> Aliran Udara 最大空气流量	1.4m <sup>3</sup> /min
<b>Max Sealed Suction (water column)</b> Sedutan Terkedap (Turus Air) 最大密封吸力(水柱)	4.2kPa (428mmH <sub>2</sub> O)
<b>Suction Power</b> Kuasa Sedutan 吸力	30W
<b>Dimensions (L x W x H)</b> Dimensi 体积	999x114x152mm (39-1/4"x4-1/2"x6")
<b>Net Weight</b> Berat Bersih 净重	1.2kg (2.7 lbs)
<b>Continuous Usage Time (approx.)</b> Masa Penggunaan Berterusan 连续使用时间	33 min with BL1850B

### DCL182FRFW

RM 1,305

### DCL182FZW

RM 648

#### Cordless Cleaner

Pembersih Vakum Tanpa Kord  
充电式便携吸尘器



- Improved front cover opens with push button for easier access

**Standard Equipment:** Floor Nozzle, Sash Nozzle, Sash Nozzle Holder, Pipe, Dust Bag, Paper Dust Bag Sps

- FRFW: 1x Rapid Charger, 1x 3.0Ah Battery (White)
- FZW: Without Charger & Battery (White)

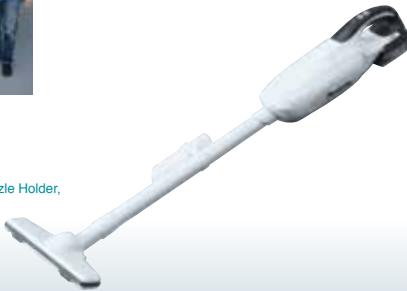

<b>Capacity</b> Kapasiti 容量	Dust Bag: 500mL Paper Pack: 330mL
<b>Max Air Flow</b> Aliran Udara 最大空气流量	1.4m <sup>3</sup> /min
<b>Max Sealed Suction (water column)</b> Sedutan Terkedap (Turus Air) 最大密封吸力(水柱)	5.4kPa (551mmH <sub>2</sub> O)
<b>Suction Power</b> Kuasa Sedutan 吸力	High: 30W   Low: 11W
<b>Dimensions (L x W x H)</b> Dimensi 体积	1,004x115x151mm (39-1/2"x4-1/2"x5-15/16")
<b>Net Weight</b> Berat Bersih 净重	1.3kg (2.8 lbs)
<b>Continuous Usage Time (approx.)</b> Masa Penggunaan Berterusan 连续使用时间	Low: 66 min   High: 33 min with BL1850B

### DVC750LZ

RM 1,507

### DVC750LZX1

RM 1,532

#### Cordless Portable Vacuum Cleaner

Pembersih Vakum Tanpa Kord  
充电式轻便吸尘器



- Two tools in one; quickly converts from vacuum to blower for increased versatility

**Standard Equipment:** Hose, Wide Nozzle, Sash Nozzle

- Z: Without Charger & Battery
- ZX1: 1x Shoulder Belt, Without Charger & Battery



<b>Capacity</b> Kapasiti 容量	Dust: 7.5L
<b>Max Air Flow</b> Aliran Udara 最大空气流量	High: 1.6m <sup>3</sup> /min   Normal: 1.3m <sup>3</sup> /min
<b>Max Sealed Suction</b> Sedutan Terkedap (Turus Air) 最大密封吸力(水柱)	High: 6.7kPa   Normal: 4.2kPa
<b>Suction Power</b> Kuasa Sedutan 吸力	High: 50W   Normal: 25W
<b>Dimensions (L x W x H)</b> Dimensi 体积	418x251x278mm (16-1/2"x9-7/8"x11")
<b>Net Weight</b> Berat Bersih 净重	4.3 - 4.6kg (9.4 - 10.1 lbs.)
<b>Continuous Usage Time (approx.)</b> Masa Penggunaan Berterusan 连续使用时间	Normal: 60 min   High: 30 min with BL1850B

### DVC350Z

RM 1,808

#### Cordless Vacuum Cleaner

Pembersih Vakum Tanpa Kord  
充电式吸尘器



- Large 3L dust bag capacity

**Standard Equipment:** Nozzle assembly, Dust Bag Assembly, Hose, Shoulder Belt

- Z: Without Charger & Battery



<b>Max Peak Air Flow</b> Aliran Udara 最大空气流量	3.4m <sup>3</sup> /min
<b>Max Sealed Suction (water column)</b> Sedutan Terkedap (Turus Air) 最大密封吸力(水柱)	5.5kPa (560mmH <sub>2</sub> O)
<b>Recoverable Capacity</b> Kapasiti 容量	Dust: 3L
<b>Dimensions (L x W x H)</b> Dimensi 体积	273x195x226mm (10-3/4"x7-5/8"x8-7/8")
<b>Net Weight</b> Berat Bersih 净重	2.2kg (4.8lbs)
<b>Continuous Usage Time (approx.)</b> Masa Penggunaan Berterusan 连续使用时间	Low: 43 min   High: 22 min with BL1850B



DVC350/DVC260 Models and specs may vary by country

\* All list price shown are for reference only (exclude SST).

\* Semua harga yang ditunjukkan adalah untuk rujukan sahaja (tidak termasuk SST). 所有显示的建议零售价仅供参考 (不包括SST)。

Cordless  
Tanpa Kord 无线式

LED Flashlight  
Lampu Sash LED  
LED照明灯

Vacuum Cleaner  
Pembersih Vakum  
吸尘器

Drilling / Fastening  
Gantut / Pengikat  
钻孔 / 紧固

Impact Drilling / Demolition  
Gantut / Penorek  
打桩机 / 拆墙机

Cutting  
Pemotong  
切割

Grinding / Sanding  
Pengkilan / Palsan  
打磨 / 砂磨

Sawing  
Gergaji  
锯切

Planing / Routing  
Pengkilan / Tumpang  
刨平 / 压花

Others  
Lain-lain  
其他

Outdoor Power Equipment  
Alatan Kuasa Luar  
户外动力设备

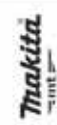

12V<sub>max</sub>

CXT

Li-ion Ah 4.0 2.0 1.5

# Cordless Cleaner

Pembersih Vakum Tanpa Kord 充电式吸尘器

Mat Nozzle 120



Seat Nozzle 120



Rubber Nozzle 330



Soft Brush 360



Blower Nozzle



## CL121DZ

RM 965

**Cordless Cleaner**  
Pembersih Vakum Tanpa Kord  
充电式吸尘器



- Comes with a variety of special nozzles optimum for cleaning car interior

**Standard Equipment:** Mat Nozzle, Seat Nozzle, Rubber Nozzle, Soft Brush, Blower Nozzle, Dust Bag, Paper Dust Bag 5pcs (194566-1), Shoulder Belt

- Z: Without Charger & Battery



<b>Capacity</b> Kapasiti 容量	Dust Bag: 500mL Paper Pack: 330mL
<b>Max Air Flow</b> Aliran Udara 最大空气流量	1.3m <sup>3</sup> /min
<b>Max Sealed Suction (water column)</b> Sedutan Terkedap (Turus Air) 最大密封吸力(水柱)	4.6kPa (470 mmH <sub>2</sub> O)
<b>Suction Power</b> Kuasa Sedutan 吸力	Max: 28W   High: 19W   Normal: 5W
<b>Dimensions (L x W x H)</b> Dimensi 体积	345x138x202mm (13-5/8"x5-7/16"x8")
<b>Net Weight</b> Berat Bersih 净重	1.7 - 1.8kg (3.7 - 4.0lbs.)
<b>Continuous Usage Time (approx.)</b> Masa Penggunaan Berterusan 连续使用时间	Normal: 33 min   High: 16 min   Max: 13 min with BL1021B

## CL108FDWYW | CL108FDZW

RM 937

RM 582

**Cordless Cleaner**  
Pembersih Vakum Tanpa Kord  
充电式便携吸尘器



- Compact and High Suction Power

**Standard Equipment:** Floor Nozzle, Sash Nozzle, Sash Nozzle Holder, Pipe, Filter, Prefilter

- WYW: 1x Standard Charger, 1x 1.5Ah Battery (White)
- ZW: Without Charger & Battery (White)



<b>Capacity</b> Kapasiti 容量	600mL
<b>Max Air Flow</b> Aliran Udara 最大空气流量	1.2m <sup>3</sup> /min
<b>Max Sealed Suction (water column)</b> Sedutan Terkedap (Turus Air) 最大密封吸力(水柱)	4.4kPa (445mmH <sub>2</sub> O)
<b>Suction Power</b> Kuasa Sedutan 吸力	Max: 30W   High: 20W   Normal: 5W
<b>Dimensions (L x W x H)</b> Dimensi 体积	956x110x150mm (37-5/8"x4-5/16"x5-7/8")
<b>Net Weight</b> Berat Bersih 净重	1.0 - 1.2kg (2.3 - 2.7lbs.)
<b>Continuous Usage Time (approx.)</b> Masa Penggunaan Berterusan 连续使用时间	Normal: 33 min   High: 16 min   Max: 13 min with BL1021B

## CL106FDWYW | CL106FDZW

RM 820

RM 465

**Cordless Cleaner**  
Pembersih Vakum Tanpa Kord  
充电式便携吸尘器



- Stronger suction power for faster cleaning with more run time

**Standard Equipment:** Floor Nozzle, Sash Nozzle, Sash Nozzle Holder, Pipe, Filter, Prefilter

- WYW: 1x Standard Charger, 1x 1.5Ah Battery (White)
- ZW: Without Charger & Battery (White)



<b>Capacity</b> Kapasiti 容量	600mL
<b>Max Air Flow</b> Aliran Udara 最大空气流量	1.3m <sup>3</sup> /min
<b>Max Sealed Suction (water column)</b> Sedutan Terkedap (Turus Air) 最大密封吸力(水柱)	3.1kPa (316mmH <sub>2</sub> O)
<b>Suction Power</b> Kuasa Sedutan 吸力	19W
<b>Dimensions (L x W x H)</b> Dimensi 体积	958x100x150mm (37-3/4"x4-3/8"x5-7/8")
<b>Net Weight</b> Berat Bersih 净重	1.0kg (2.2 lbs.)
<b>Continuous Usage Time (approx.)</b> Masa Penggunaan Berterusan 连续使用时间	21 min with BL1021B

## CL107FDWYW | CL107FDZW

RM 982

RM 628

**Cordless Cleaner**  
Pembersih Vakum Tanpa Kord  
充电式便携吸尘器



- 3 mode suction power settings

**Standard Equipment:** Floor Nozzle, Sash Nozzle, Sash Nozzle Holder, Pipe, Dust Bag, Paper Dust Bag 5pcs (194566-1)

- WYW: 1x Standard Charger, 1x 1.5Ah Battery (White)
- ZW: Without Charger & Battery (White)



<b>Capacity</b> Kapasiti 容量	Dust Bag: 500mL Paper Pack: 330mL
<b>Max Air Flow</b> Aliran Udara 最大空气流量	1.4m <sup>3</sup> /min
<b>Max Sealed Suction (water column)</b> Sedutan Terkedap (Turus Air) 最大密封吸力(水柱)	5.0kPa (510mmH <sub>2</sub> O)
<b>Suction Power</b> Kuasa Sedutan 吸力	Max: 32W   High: 20W   Normal: 5W
<b>Dimensions (L x W x H)</b> Dimensi 体积	960x112x150mm (37-3/4"x4-3/8"x5-7/8")
<b>Net Weight</b> Berat Bersih 净重	1.1kg (2.5lbs.)
<b>Continuous Usage Time (approx.)</b> Masa Penggunaan Berterusan 连续使用时间	Normal: 25 min   High: 12 min   Max: 10 min with BL1021B

\* All list price shown are for reference only (exclude SST).

\* Semua harga yang ditunjukkan adalah untuk rujukan sahaja (tidak termasuk SST). 所有显示的建议零售价仅供参考 (不包括SST)。

Cordless  
Tanpa Kord 无线式

LED Flashlight  
Lampu Saha LED  
LED 手电筒

Vacuum Cleaner  
Pembersih Vakum  
吸尘器

Drilling | Fastening  
Ganda | Pengikat  
钻孔 | 紧固

Impact Drilling | Demolition  
Ganda | Pencah  
冲击钻孔 | 拆除加工

Cutting  
Pemotong  
切割

Grinding | Sanding  
Pengamir | Pasiran  
打磨 | 砂磨

Sawing  
Ganda  
锯切

Planing | Routing  
Pengamir | Tengking  
刨削 | 雕刻

Others  
Lain-lain  
其他

Outdoor Power Equipment  
Alatan Kuasa Luar  
园具 - 户外

Makita



**CL100DW | CL100DZ**  
RM 623 | RM 278

**Cordless Cleaner**  
Pembersih Vakum Tanpa Kord  
充电式便携吸尘器



- Increased storage capacity for longer time between waste disposal

**Standard Equipment:** Floor Nozzle, Sash Nozzle, Sash Nozzle Holder, Pipe, Filter, Prefilter

- W: 1x Standard Charger, 1x 1.3Ah Battery (White)
- Z: Without Charger & Battery (White)



<b>Capacity</b> Kapasiti 容量	600mL
<b>Max Air Flow</b> Aliran Udara 最大空气流量	1.3m <sup>3</sup> /min
<b>Max Sealed Suction (water column)</b> Sedutan Terkedap (Turus Air) 最大密封吸力(水柱)	2.3kPa (235mmH <sub>2</sub> O)
<b>Suction Power</b> Kuasa Sedutan 吸力	14W
<b>Dimensions (L x W x H)</b> Dimensi 体积	966x103x150mm (38-1/32"x4-1/16"x5-7/8")
<b>Net Weight</b> Berat Bersih 净重	0.88kg (1.94lbs)
<b>Continuous Usage Time (approx.)</b> Masa Penggunaan Berterusan 连续使用时间	12 min with BL1013

**CL102DW | CL102DZ**  
RM 752 | RM 428

**Cordless Cleaner**  
Pembersih Vakum Tanpa Kord  
充电式便携吸尘器



- Quick clean-ups with strong suction power

**Standard Equipment:** Floor Nozzle, Sash Nozzle, Sash Nozzle Holder, Pipe, Dust Bag, Paper Dust Bag 5pcs

- W: 1x Standard Charger, 1x 1.3Ah Battery (White)
- Z: Without Charger & Battery (White)

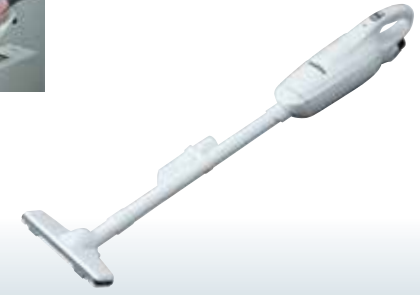

<b>Capacity</b> Kapasiti 容量	Dust Bag: 500mL Paper Pack: 330mL
<b>Max Air Flow</b> Aliran Udara 最大空气流量	1.1m <sup>3</sup> /min
<b>Max Sealed Suction (water column)</b> Sedutan Terkedap (Turus Air) 最大密封吸力(水柱)	2.7kPa (275mmH <sub>2</sub> O)
<b>Suction Power</b> Kuasa Sedutan 吸力	High: 14W   Low: 6W
<b>Dimensions (L x W x H)</b> Dimensi 体积	984x113x150mm (38-3/4"x4-7/16"x5-7/8")
<b>Net Weight</b> Berat Bersih 净重	1.1kg (2.4lbs)
<b>Continuous Usage Time (approx.)</b> Masa Penggunaan Berterusan 连续使用时间	Low: 21 min   High: 13 min with BL1013

**CL111DWI | CL111DWR**  
RM 895 | RM 895

**Cordless Cleaner**  
Pembersih Vakum Tanpa Kord  
充电式便携吸尘器



**With Built-in Battery**  
Dengan Bateri Terbina Dalam  
内置电池

- LED light indicates when to charge battery

**Standard Equipment:** Nozzle for Flooring & Carpet, Sash Nozzle, Sash Nozzle Holder, Pipe, Adapter

- WI (Ivory): 1x Standard Charger, Built-in 1.5Ah Battery, Dust Bag, Paper Dust Bag 5pcs
- WR (Red): 1x Standard Charger, Built-in 1.5Ah Battery, Filter, Prefilter

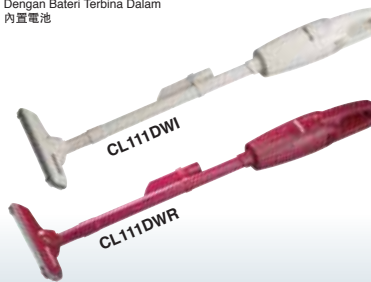

<b>Capacity</b> Kapasiti 容量	560mL
<b>Max Air Flow</b> Aliran Udara 最大空气流量	1.4m <sup>3</sup> /min
<b>Max Sealed Suction (water column)</b> Sedutan Terkedap (Turus Air) 最大密封吸力(水柱)	3.4kPa (350mmH <sub>2</sub> O)
<b>Suction Power</b> Kuasa Sedutan 吸力	21W
<b>Dimensions (L x W x H)</b> Dimensi 体积	906x102x109mm (35-3/4"x4"x4-1/4")
<b>Net Weight</b> Berat Bersih 净重	0.94kg (2.1lbs.)
<b>Continuous Usage Time (approx.)</b> Masa Penggunaan Berterusan 连续使用时间	12 min with Built-in Lithium-ion Battery

**CL104DWYX | CL104DWY**  
RM 590 | RM 590

**Cordless Cleaner**  
Pembersih Vakum Tanpa Kord  
充电式便携吸尘器

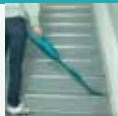

**With Built-in Battery**  
Dengan Bateri Terbina Dalam  
内置电池

- Increased storage capacity for longer time between waste disposal

**Standard Equipment:** Floor Nozzle, Sash Nozzle, Sash Nozzle Holder, Pipe, Dust Bag, Adapter (DC1001), Paper Dust Bag 5pcs (194566-1)

- WYX: 1x Standard Charger, Built-in 1.5Ah Battery (Blue)
- WY: 1x Standard Charger, Built-in 1.5Ah Battery (White)

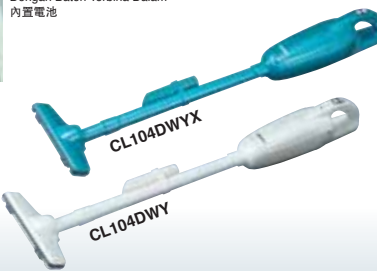

<b>Capacity</b> Kapasiti 容量	Dust Bag: 500mL Paper Pack: 330mL
<b>Max Air Flow</b> Aliran Udara 最大空气流量	1.1m <sup>3</sup> /min
<b>Max Sealed Suction (water column)</b> Sedutan Terkedap (Turus Air) 最大密封吸力(水柱)	3.3kPa (340mmH <sub>2</sub> O)
<b>Suction Power</b> Kuasa Sedutan 吸力	Turbo: 20W   High: 14W   Low: 5W
<b>Dimensions (L x W x H)</b> Dimensi 体积	983x113x136mm (38-3/4"x4-7/16"x5-3/8")
<b>Net Weight</b> Berat Bersih 净重	1.1kg (2.3lbs)
<b>Continuous Usage Time (approx.)</b> Masa Penggunaan Berterusan 连续使用时间	Low: 30 min   High: 15 min   Turbo: 10 min with Built-in Lithium-ion Battery

**CL105DW | CL105DWX**  
RM 570 | RM 570

**Cordless Cleaner**  
Pembersih Vakum Tanpa Kord  
充电式便携吸尘器



**With Built-in Battery**  
Dengan Bateri Terbina Dalam  
内置电池

- Strong suction power of 20W

**Standard Equipment:** Floor Nozzle, Sash Nozzle, Sash Nozzle Holder, Pipe, Dust Bag, Adapter (DC1001), Paper Dust Bag 5pcs (194566-1)

- W: 1x Standard Charger, Built-in 1.3Ah Battery (White)
- WX: 1x Standard Charger, Built-in 1.3Ah Battery (Blue)

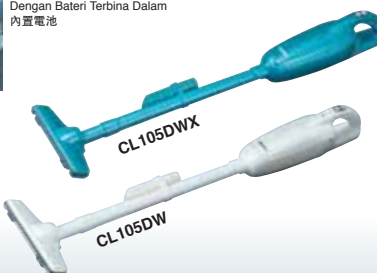

<b>Capacity</b> Kapasiti 容量	Dust Bag: 500mL Paper Pack: 330mL
<b>Max Air Flow</b> Aliran Udara 最大空气流量	1.1m <sup>3</sup> /min
<b>Max Sealed Suction (water column)</b> Sedutan Terkedap (Turus Air) 最大密封吸力(水柱)	3.3kPa (340mmH <sub>2</sub> O)
<b>Suction Power</b> Kuasa Sedutan 吸力	Turbo: 20W   High: 14W   Low: 5W
<b>Dimensions (L x W x H)</b> Dimensi 体积	983x113x136mm (38-3/4"x4-7/16"x5-3/8")
<b>Net Weight</b> Berat Bersih 净重	1.1kg (2.3lbs)
<b>Continuous Usage Time (approx.)</b> Masa Penggunaan Berterusan 连续使用时间	Low: 20 min   High: 10 min   Turbo: 7 min with Built-in Lithium-ion Battery

\* All list price shown are for reference only (exclude SST).

\* Semua harga yang ditunjukkan adalah untuk rujukan sahaja (tidak termasuk SST). 所有显示的建议零售价仅供参考 (不包括SST)。

Cordless  
Tanpa Kord 无线

LED Flashlight  
Lampu Sash LED  
LED照明灯

Vacuum Cleaner  
Pembersih Vakum  
吸尘器

Drilling / Fastening  
Gergaji / Pengikat  
钻孔 / 紧固

Impact Drilling / Demolition  
Gergaji / Penorek  
打桩机 / 拆墙机

Cutting  
Pemotong  
切割

Grinding / Sanding  
Pengkilan / Palsan  
研磨 / 打磨

Sawing  
Gergaji  
锯切

Planing / Routing  
Pengkilan / Tunggam  
刨平 / 雕刻

Others  
Lain-lain  
其他

Outdoor Power Equipment  
Alatan Kiri Luar  
园机/户外

makita  
Makita

# Cordless Cleaner

Pembersih Vakum Tanpa Kord 充电式吸尘器

7.2V

Li-ion Ah 1.5

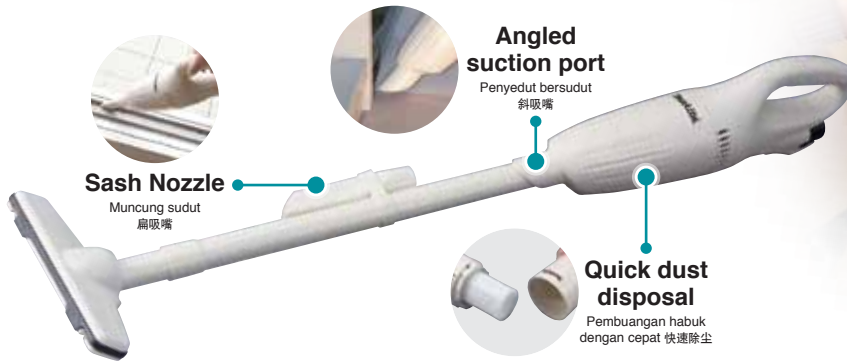

**Sash Nozzle**  
Muncung sudut  
扁吸嘴

**Angled suction port**  
Penyedut bersudut  
斜吸嘴

**Quick dust disposal**  
Pembuangan habuk dengan cepat  
快速除尘

## CL070DZ

RM 263

### Cordless Cleaner

Pembersih Vakum Tanpa Kord  
充电式便携吸尘器



- Increased storage capacity for longer time between waste disposal



<b>Capacity</b> Kapasiti 容量	600mL
<b>Max Air Flow</b> Aliran Udara 最大空气流量	1.2m <sup>3</sup> /min
<b>Max Sealed Suction (water column)</b> Sedutan Terkedap (Turus Air) 最大密封吸力(水柱)	1.8kPa (180mmH <sub>2</sub> O)
<b>Suction Power</b> Kuasa Sedutan 吸力	14W
<b>Dimensions (L x W x H)</b> Dimensi 体积	966x103x142mm (38-1/32"x4-1/16"x5-5/8")
<b>Net Weight</b> Berat Bersih 净重	0.81kg (1.8lbs)
<b>Continuous Usage Time (approx.)</b> Masa Penggunaan Berterusan 连续使用时间	8 min with BL7010

**Standard Equipment:** Floor Nozzle, Sash Nozzle, Sash Nozzle Holder, Pipe, Filter, Prefilter

• Z: Without Charger & Battery (White)

# Cordless Cleaner

Pembersih Vakum Tanpa Kord 充电式吸尘器

18V

G-Battery

Li-ion Ah 1.3

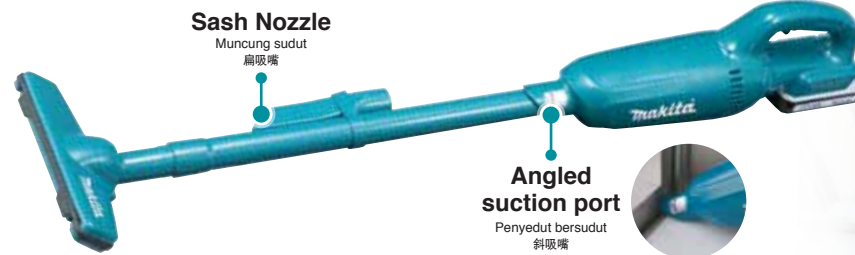

**Sash Nozzle**  
Muncung sudut  
扁吸嘴

**Angled suction port**  
Penyedut bersudut  
斜吸嘴



## CL183DZX

RM 272

### Cordless Cleaner

Pembersih Vakum Tanpa Kord  
充电式便携吸尘器



- Compact and lightweight design



<b>Capacity</b> Kapasiti 容量	600mL
<b>Max Air Flow</b> Aliran Udara 最大空气流量	1.3m <sup>3</sup> /min
<b>Max Sealed Suction (water column)</b> Sedutan Terkedap (Turus Air) 最大密封吸力(水柱)	2.6kPa (270mmH <sub>2</sub> O)
<b>Suction Power</b> Kuasa Sedutan 吸力	17W
<b>Dimensions (L x W x H)</b> Dimensi 体积	966x102x148mm (38"x4"x5-7/8")
<b>Net Weight</b> Berat Bersih 净重	1.2kg (2.6lbs.)
<b>Continuous Usage Time (approx.)</b> Masa Penggunaan Berterusan 连续使用时间	30 min with BL1815G

**Standard Equipment:** Floor Nozzle, Sash Nozzle, Sash Nozzle Holder, Pipe, Filter, Prefilter

• ZX: Without Charger & Battery

\* All list price shown are for reference only (exclude SST).

\* Semua harga yang ditunjukkan adalah untuk rujukan sahaja (tidak termasuk SST). 所有显示的建议零售价仅供参考 (不包括SST)。

Cordless  
Tanpa Kord 无线式

LED Flashlight  
Lampu Suka LED  
LED照明灯

Vacuum Cleaner  
Pembersih Vakum  
吸尘器

Drilling | Fastening  
Gantol | Pasang  
钻孔 | 紧固

Impact Drilling | Demolition  
Gantol | Pencah  
冲击钻孔 | 拆除加工

Cutting  
Pemotongan  
切割

Grinding | Sanding  
Pengkilan | Polesan  
打磨 | 砂磨

Sawing  
Gergaji  
锯切

Planing | Routing  
Pengkilan | Tengking  
刨削 | 雕刻

Others  
Lain-lain  
其他

Outdoor Power Equipment  
Alatan Kerja Luar  
园具·户外



# Centrifugal force separates fine dust, allowing the main unit of the cleaner to require about 80% less frequent dust disposal

Daya sentrifugal memisahkan debu halus, mengurangkan kekerapan pembersihan penapis kira-kira 80%  
 离心力将细小的灰尘分开, 使清洁器的主机减少了大约80%的频繁灰尘处理



**Cyclone pre-separation system separates dust from air**

Sistem pra-pemisahan siklon memisahkan debu dari udara  
 旋风分离系统将灰尘与空气隔离



Dust case

**Easy disposal of the fine dust collected in dust case**

Debu halus dikumpulkan dalam pengumpul habuk mudah dibersihkan  
 集尘箱中收集的细粉尘方便处理



**The main unit of the cleaner requires much less frequent dust disposal**

Mangurangkan kekerapan pembersihan pengumpul habuk  
 减少清空集尘箱频率

## Cyclone Attachment Set

Set Pengumpul Habuk Siklon 旋风集尘配件

### Pipe lock

DCL280F, DCL281F, DCL282F

Part No.191D71-3 (White)  
 Part No.191D73-9 (Black)



Dust capacity **400mL** / Net weight **0.36kg**

CL106FD, CL107FD, CL108FD, DCL180, DCL181F, DCL182, CL183D

Part No.199491-1 (White)  
 Part No.191D75-5 (Black)



Dust capacity **400mL** / Net weight **0.35kg**

### Easily fitting

Mudah dipasang 轻松拟合



With short pipe (Part No.191D76-3)



With short pipe (Part No.191D79-7)

Without standard pipe (Part No.451241-5)



By using this short pipe when attaching Cyclone attachment, you can use the cleaner with the same overall length as the cleaner without Cyclone attachment

Dengan menggunakan paip pendek ini apabila bersambung dengan set pengumpul habuk siklon, anda boleh menggunakan pembersih dengan panjang keseluruhan yang sama seperti pembersih tanpa set pengumpul habuk siklon  
 安装旋风集尘配件时使用此短管, 可以使吸尘机的总长度与不安装旋风集尘配件的吸尘机相同

## Pipe lock DCL280F, DCL281F, DCL282F

Pipe is fixed with the locking mechanism to prevent it from accidentally coming off

Paip dengan mekanisme penguncian untuk mengelakkannya dari jatuh tanpa sengaja 管锁固定以防止意外脱落



## Pipe with beveled end

Cleaning of tight places can be done without nozzle by using the beveled end of pipe as a nozzle

Paip serong bertindak sebagai muncung untuk membersihkan kawasan sempit  
 倒角管的倾斜端作为喷嘴可以清洁狭窄的地方



Suction Power Keep

**90%\***



\*When used with DCL182 (wood dust)

Cordless 无线吸尘  
 LED Flashlight 照明灯 LED 照明灯  
 Vacuum Cleaner 吸尘器  
 Drilling / Fastening 钻孔 / 紧固  
 Impact Drilling / Demolition 冲击钻孔 / 拆除  
 Cutting 切割  
 Grinding / Sanding 研磨 / 打磨  
 Sawing 锯切  
 Planing / Routing 刨平 / 开槽  
 Others 其他  
 Outdoor Power Equipment 户外动力设备  
**Makita**

Cordless  
Turret Hood Light

LED Flashlight  
Lampu Senter LED  
LED 手电筒

Vacuum Cleaner  
Penyerbuk Vakum  
吸尘器

Drilling / Fastening  
Drooi / Pengikat  
钻孔 / 紧固

Impact Drilling / Demolition  
Drooi / Perusak  
冲击钻孔 / 拆除加工

Cutting  
Pemotong  
切割

Grinding / Sanding  
Pengkilan / Pasiran  
打磨 / 砂磨

Sawing  
Dempul  
切割

Planing / Routing  
Pengaliran / Tenggang  
刨削 / 雕刻

Others  
Lain-lain  
其他

Outdoor Power Equipment  
Alatan Kuasa Luar  
园具 / 户外



# For Cleaning



Model  
DVC340 / DVC350 /  
DVC860L / DVC861L /  
DVC862L / DVC863L



Model  
DVC261 / DVC265



**Hose 38mm-1.5m with front sleeve**

**Hose 32mm with front sleeve 1m, 1.7m**

**Hose 28mm without front sleeve 1m, 1.5m**

**Front cuffs 22**

See page P226

**Hose 38mm 1.5m**

**Bending pipe assembly**  
For aluminum straight pipe with lock  
\*with Hose 28 sleeve

**Bending pipe assembly**  
For plastic straight pipe  
\*with Hose 28 sleeve

**Bending pipe**      **Straight pipe**

**Aluminum Telescopic pipe assembly**  
Pipe length is variably adjustable from 590 to 942mm.

**Plastic Telescopic pipe assembly**  
Pipe length is variably adjustable from 500 to 850mm.

**Tapered nozzle set**

**Nozzle assembly 28 Flat type**

**F/C switching T-nozzle 28**

**Floor/carpet T-nozzle**

**Floor T-nozzle 28**

**Seat nozzle 28**

**Corner nozzle 300-28**

**Crevice nozzle 415**

**Round brush**

**Shelf brush**

**Flexible rubber nozzle**

**Tapered nozzle set**

**Nozzle assembly 38 Flat type**

**F/C switching T-nozzle 38**

**Universal Type Nozzle assembly 38**

**Compact Type**

**Round brush**

**Corner nozzle**

## Cordless Cleaner System charts

**Model**  
Makita all Cordless Cleaners

**28-J Straight pipe**

**28-K Flexible hose**

**28-Q Flexible rubber nozzle**

**28-M Round brush**

**28-O Sash nozzle**

**28-L Nozzle assembly**

**28-N Corner nozzle**

**28-P Shelf brush**

## For Dust Collecting

See page P216

**W/ Ø28mm Hose**  
Model  
DVC350 / DVC861L  
DVC863L / DVC864L

**W/ Front cuffs**  
38 24 22

**W/ Ø38mm Hose**  
Model  
DVC860L / DVC861L  
DVC862L / DVC863L  
DVC750L

**W/ Joint 22-38**

**W/ Ø28mm Hose**  
Model  
DVC261 / DVC265

**W/ Front cuffs**  
38 24 22

### Attachments

### For Cordless Cleaner 28-J Straight pipe



Description	Color	Part No.	EU	
			Part No.	
Aluminum Telescopic pipe assembly Pipe length is variably adjustable from 590 to 942mm.	Aluminum	140G19-0	-	
Telescopic pipe assembly 28 Pipe length is variably adjustable from 500 to 850mm.	White	198559-0	198560-5	
Plastic straight pipe 28	Ivory	451424-7	-	
	White	451241-5	-	
	Blue	451244-9	-	
	Red	451425-5	-	
	Pink	457231-6	-	
	Black	456587-4	-	

### 28-K Flexible hose set28



Description	Color	Part No.	EU	
			Part No.	
Flexible hose set28  Superior in flexibility and for the cleaning of the small place in the car	Ivory	191496-7	198544-3	
	White	198867-9	198868-7	
	Blue	198541-9	198545-1	
	Red	198542-7	198546-9	
	Pink	198870-0	198871-8	
	Black	198543-5	198547-7	

### 28-L Nozzle assembly Flat type



F/C switching t-nozzle 28

Description	Color	Part No.	EU	
			Part No.	
Flat type	Black	199454-7	-	
F/C switching t-nozzle 28 Flooring & carpet	White	198183-9	198532-0	
F/C switching t-nozzle 28 Flooring & carpet	Blue	199431-9	-	

Cordless  
Tape Roll 10.8V

LED Flashlight  
Lampo Saku LED  
LED08803

Vacuum Cleaner  
Tambak Vakuu  
真空吸尘器

Drilling / Fastening  
Garuhi / Pengikat  
钻孔 / 紧固

Impact Drilling / Demolition  
Garuhi / Perusak  
冲击钻孔 / 拆除

Cutting  
Pemotong  
切割

Grinding / Sanding  
Pijiliran / Pasir  
打磨 / 砂磨

Sawing  
Gergaji  
锯切

Planing / Routing  
Pijiliran / Tenggam  
刨削 / 雕刻

Others  
Lain-lain  
其他

Outdoor Power Equipment  
Alat-alat Listrik  
户外电源

Makita  
1915

Cordless  
Turret Head 角磨机

LED Flashlight  
Lampu Senter LED  
LED 手电筒

Vacuum Cleaner  
Penyedot Vakum  
吸尘器

Drilling / Fastening  
Gantol / Pengikat  
钻头 / 螺帽

Impact Drilling / Demolition  
Gantol / Perusak  
起钉钻头 / 砸墙加工

Cutting  
Pemotong  
切割

Grinding / Sanding  
Pengkilan / Pasiran  
打磨 / 砂磨

Sawing  
Dempul  
切割

Planing / Routing  
Pengaliran / Tenggang  
刨削 / 雕刻

Others  
Lain-lain  
其他

Outdoor Power Equipment  
Alat-alat Listrik  
园林工具

Makita  
MAKITA

**Nozzle assembly**

Floor/carpet t-nozzle  
For rug / carpet cleaning



Description	Color	Part No.	EU
			Part No.
Floor/carpet t-nozzle For rug / carpet cleaning	Ivory	198150-4	198149-9
	White	198525-7	198528-1
	Blue	198523-1	198527-3
	Red	198524-9	198522-3
	Pink	198882-3	198883-1
	Black	198526-5	198529-9

**Nozzle assembly**

Floor t-nozzle 28



Description	Color	Part No.
Floor t-nozzle 28	Ivory	123485-4
	White	123486-2
	Blue	123488-8
	Red	123489-6
	Pink	123843-4
	Black	123539-7

**Nozzle assembly**

For rug / carpet cleaning



Description	Color	Part No.	EU
			Part No.
For rug / carpet cleaning	Ivory	122291-4	-

**Nozzle assembly**

Seat nozzle 28



Description	Color	Part No.	EU
			Part No.
Seat nozzle 28 For car seat	White	199037-3	199038-1
	Blue	199040-4	199041-2
	Black	198921-9	199039-9

**28-M**

**Round brush 28**



Color	Part No.	EU
		Part No.
Ivory	198548-5	198552-4
White	198877-6	198878-4
Blue	198549-3	198553-2
Red	198550-8	198554-0
Pink	198880-7	198881-5
Black	198551-6	198555-8

**28-N**

**Corner nozzle 330-28**

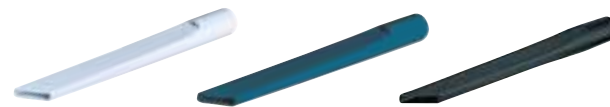

Size	Color	Part No.	EU
			Part No.
330-28mm	White	198918-8	198919-6
	Blue	198989-5	198990-0
	Black	198991-8	198992-6

**28-O**

**Sash nozzle 28 and Long Sash nozzle 415**

Sash nozzle 28



Long Sash nozzle 415



Description	Color	Part No.
Sash nozzle 28	Ivory	416041-0
	White	451240-7
	Blue	451243-1
	Red	416225-0
	Pink	457228-5
Crevice nozzle 415 set	Black	456586-6
	White	199439-3



**28-P**

**Shelf brush set 28**

(For gentle cleaning by soft-tipped brush)



Color	Part No.	EU	
		Part No.	
Ivory	191724-0	198537-0	
White	198872-6	198873-4	
Blue	198534-6	198538-8	
Red	198535-4	198539-6	
Pink	198875-0	198876-8	
Black	198536-2	198540-1	

**28-Q**

**Flexible rubber nozzle**



Color	Part No.	EU	
		Part No.	
gray	197900-4	197901-2	

**28-I**

**Tapered nozzle set**

Use with Front cuts 22 or Flexible rubber nozzle



Color	Part No.	EU	
		Part No.	
gray	192236-6	198558-2	

**Cordless Cleaner for Capsule type**

For Model: CL183D, DCL181F, DCL180, CL111D, CL106FD, CL070D  
Filter



Pre filter

Easy shake off dust filter

Description	Per pkg.	Part No.	EU	
			Part No.	
Filter	10	198914-6	198915-4	
Pre filter	1	198750-0	198751-8	
Easy shake off dust filter	1	198752-6	198753-4	

**Cordless Cleaner for Paper bag type**

For Model: DCL182, CL121D, CL107FD, CL105D, CL104D, CL072D  
Paper filter



Dust bag



Easy shake off dust bag

Description	Per pkg.	Part No.	EU	
			Part No.	
Paper filter Anti-bacterial type	10	194565-3	198744-5	
	5	194566-1	198745-3	
Dust bag	1	198746-1	198747-9	
Easy shake off dust bag	1	198748-7	198749-5	

**Other Cleaners**

**For DVC261, DVC265**

Dust bag assembly



Filter bag set (Paper dust bag)

Description	Per pkg.	Part No.	EU	
			Part No.	
Dust bag assembly	1	197898-5	197899-3	
Filter bag set (Paper dust bag)	10	197902-0	197903-8	

**Hose**



Description	Size	Part No.
without front sleeve	28mm-1m	143787-2
without front sleeve	28mm-1.5m	144408-9
with front sleeve	32mm-1.1m	199453-9
with front sleeve	38mm-1.5m	199388-4
with Front cuffs 38, Hose connection 38mm	38mm-1.5m	198757-6

**Bending pipe assembly**

\*with Hose 28 sleeve



Description	Part No.
For Aluminum Telescopic pipe assembly with lock	140G26-3
	*127093-3
For plastic straight pipe 28 and Telescopic pipe assembly 28	458184-2
	*126756-8

Cordless  
Tampok Kord 1800W

LED Flashlight  
Lampu Saku LED  
LED030803

Vacuum Cleaner  
Pembersih Vakuum  
V1800

Drilling / Fastening  
Gergaji / Pengikat  
DR11 / DR12

Impact Drilling / Demolition  
Gergaji / Perusak  
DR13 / DR14 / DR15

Cutting  
Pemotong  
DR16

Grinding / Sanding  
Pengkilan / Pasir  
DR17 / DR18

Sawing  
Gergaji  
DR19

Planing / Routing  
Pengkilan / Tumpang  
DR20 / DR21

Others  
Lain-lain  
DR22

Outdoor Power Equipment  
Alat-alat Listrik  
DR23 / DR24

Outdoor Power Equipment  
Alat-alat Listrik  
DR25 / DR26

Makita  
1910

Cordless  
Turret Head Style

LED Flashlight  
Lampu Senter LED  
LED照灯

Vacuum Cleaner  
Pembersih Vakum  
吸尘器

Drilling / Fastening  
Ganda / Pengikat  
钻、紧固

Impact Drilling / Demolition  
Ganda / Perusak  
起工钻、砸墙加工

Cutting  
Pemotong  
切割

Grinding / Sanding  
Pengkil / Pasir  
打磨 / 砂磨

Sawing  
Gergaji  
锯切

Planing / Routing  
Pengaliran / Tenggam  
刨削 / 雕刻

Others  
Lain-lain  
其他

Outdoor Power Equipment  
Alat-alat Listrik  
园机、户外



### For CL121D

Mat nozzle 120



Seat nozzle 120 complete



Rubber nozzle 330



Soft brush 360 complete



Description	Part No.
Mat nozzle 120	459056-4
Seat nozzle 120 complete	140H95-0
Rubber nozzle 330	422437-5
Soft brush 360 complete	140H94-2

### For DRC200

Boundary line tape (15m roll)



Side brushes



Power brush



Turn brush cover



Filter



Description	Part No.
Boundary line tape (15m roll)	SH00000231 (EU)
	SH00000240 (USA, AU)
Side brushes	SH00000065
Power brush	SH00000063
Turn brush cover	SH00000064
Filter	SH00000213

### For DVC350 Dust bag



Part No.
122918-6

### Nozzle assembly



Model No.	Size(mm)	Part No.
DVC350	220	132025-7
	430	134182-7

### For DVC750L

#### Pre filter and Damper

(Dry use only)

Pre filter



Damper



Pre filter and Damper set

Item	Part No.
Pre filter	162635-6
Damper	422449-8
Pre filter and Damper set	199827-4

### Quick charger

(AC only)



Model No.	Charging time (min.) (approx.)	Part No.
CL104D, CL105D, CL111D	180	DC1001

### For DCL501



	Type	Part No.
Hose	-	SH00000034
Straight pipe	Adjustable length	SH00000060
Nozzle assembly	Flooring & carpet	SH00000058
Crevice nozzle	-	SH00000042

### Flexible hose set

(Total length: 95cm)



Model No.	Part No.
DUB142, DUB182, UB1100, UB1101	191750-9
UB1102, UB1103	196643-5

# VACUUM CLEANER

## Automatic Self-cleaning Filtration System achieved by two filter units

Sistem Penapis Penyucian Automatik 自动清洗过滤系统

Constantly high suction power throughout operation because dust is removed from Prefilters every 10 seconds during operation

Kuasa penyedut yang berterusan sepanjang operasi kerana habuk dikeluarkan dari penapis setiap 10 saat semasa operasi

在整个运行过程中吸力保持在较高的水平，因为在运行过程中，每10秒就会从过滤器中除去灰尘

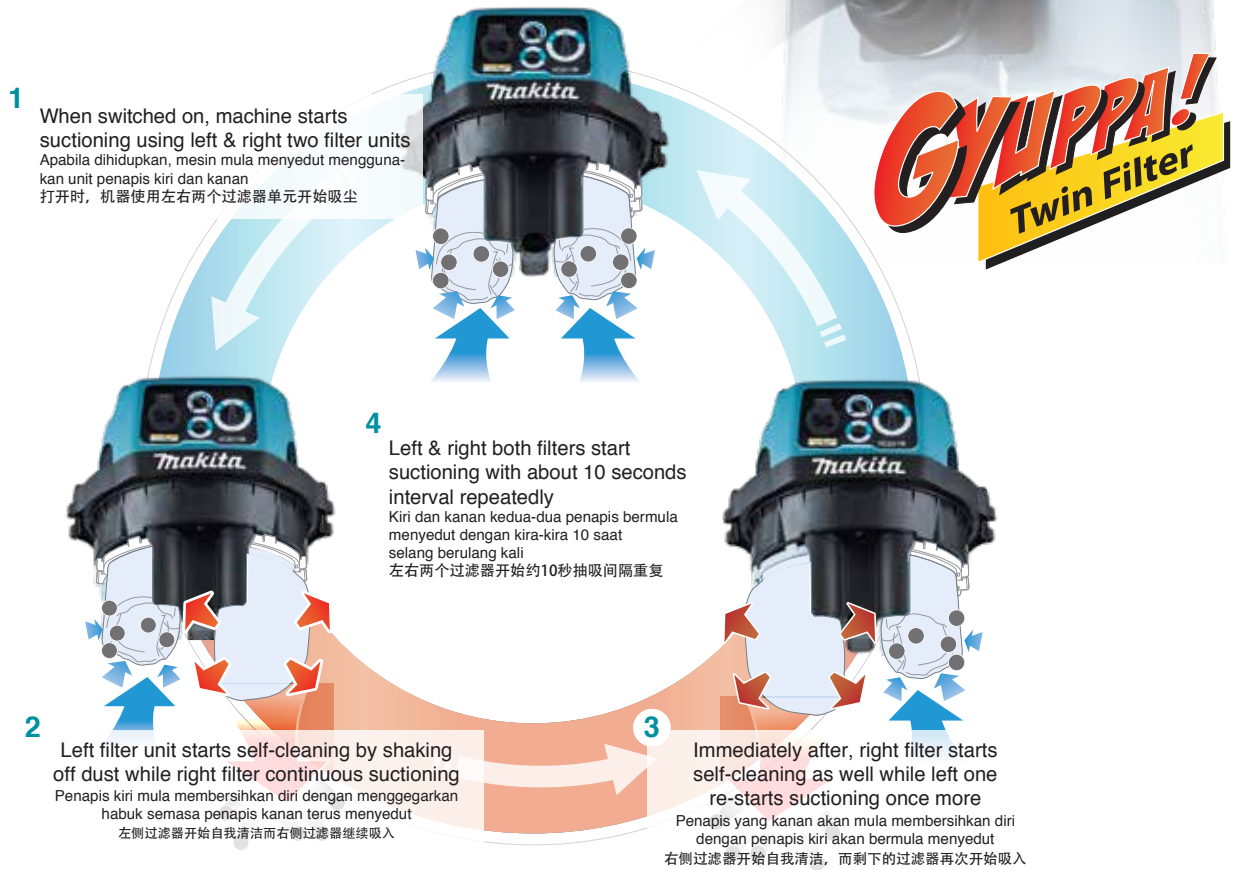

### VC3211M

#### Vacuum Cleaner (Wet & Dry)

Pembersih Vakum (Basah Dan Kering)  
吸尘器(干湿两用)

- 32L Large dust bag capacity enables continuous cleaning work  
Kapasiti debu 32L besar boleh membersihkan secara berterusan  
32L大容量尘袋可延续清洁工作

Standard Equipment: Hose, Holder 10-33, Front Cuffs (22, 24, 38), Cloth Filter, Poly Bag Set 10pcs



Dust Class M  
Debu Kelas M | 集尘等级M

WET Basah 湿  
DRY Kering 干



#### AUTOMATIC Self-cleaning Filtration System

Sistem Penapis Penyucian Automatik  
自动清洗过滤系统

Continuous Rating Input 1,050W

Kuasa Sedutan 额定输入功率

Max Peak Air Flow 2.0m<sup>3</sup>/min

Aliran Udara 最大空气流量

Max Sealed Suction (water column) 22.0kPa (2,240 mmH<sub>2</sub>O)

Sedutan Terkedap (Turus Air) 最大密封吸力(水柱)

Tank Capacity Dust: 32L

Kapasiti 容量

Dimensions (L x W x H) Water: 27L

Dimensi 体积

Net Weight (21-3/4"x15-5/8"x27")

Berat Bersih 净重

Power Supply Cord 16.9kg (37.3lbs)

Kabel Wayar 电源线

5.0m (16.4ft)

### VC2211M

#### Vacuum Cleaner (Wet & Dry)

Pembersih Vakum (Basah Dan Kering)  
吸尘器(干湿两用)

- Approved for Dust Class M in accordance with the EU standard  
Diluluskan oleh piawaian EU untuk menyedut debu kelas M  
依欧盟标准，集尘等级M

Standard Equipment: Hose, Front Cuffs (22, 24, 38), Belt Hook, Hose Band, Cap, Poly bag 800x650, Poly Bag Set 10 pcs



Dust Class M  
Debu Kelas M | 集尘等级M

WET Basah 湿  
DRY Kering 干



#### AUTOMATIC Self-cleaning Filtration System

Sistem Penapis Penyucian Automatik  
自动清洗过滤系统

Continuous Rating Input 1,050W

Kuasa Sedutan 额定输入功率

Max Peak Air Flow 2.0m<sup>3</sup>/min

Aliran Udara 最大空气流量

Max Sealed Suction (water column) 22.0kPa (2,240 mmH<sub>2</sub>O)

Sedutan Terkedap (Turus Air) 最大密封吸力(水柱)

Tank Capacity Dust: 22L

Kapasiti 容量

Dimensions (L x W x H) Water: 17L

Dimensi 体积

Net Weight (21-3/4"x15-5/8"x22-3/8")

Berat Bersih 净重

Power Supply Cord 16.3kg (35.9lbs)

Kabel Wayar 电源线

5.0m (16.4ft)

Cordless  
Tapis Kord 无线

LED Flashlight  
Lampu Suluh LED  
LED照明灯

Vacuum Cleaner  
Pembersih Vakum  
吸尘器

Drilling / Fastening  
Gagah / Pengikat  
钻孔 / 紧固

Impact Drilling / Demolition  
Gagah / Pencah  
打桩机 / 拆墙机

Cutting  
Pemotong  
切割

Grinding / Sanding  
Pencil / Pencil  
打磨 / 打磨

Sawing  
Gagah  
锯切

Planing / Routing  
Penyalin / Tonggah  
刨平 / 刨平

Others  
Lain-lain  
其他

Outdoor Power Equipment  
Alatan Kuasa Luar  
户外动力工具

Makita  
MAKITA

# VACUUM CLEANER

## Automatic self-cleaning filter (VC1310L, VC2510L, VC3210L)

Sistem Penapis Penyucian Automatik 自动清洗过滤系统

obtained by Triple filter structure composed of:  
**Powder filter + Damper + Prefilter**

Kuasa penyedutan yang berterusan sepanjang operasi kerana habuk dikeluarkan dari Prefilters setiap 10 saat semasa operasi

由三重过滤器结构得到：粉末过滤器+阻尼器+预过滤器

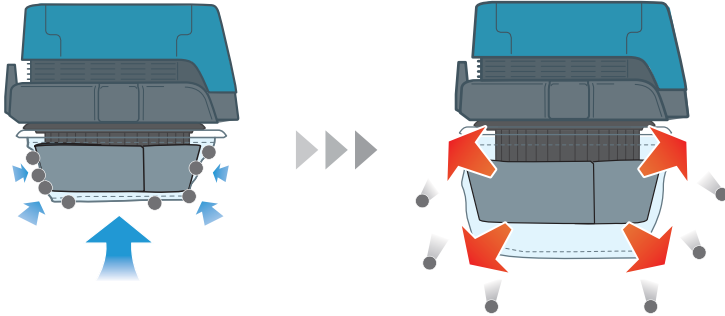

When the power is switched on, Prefilter collapses into itself to compress Damper, and fits closely over Damper and Powder filter.

Apabila kuasa dihidupkan, Prefilter runtuh ke dalamnya untuk memampatkan Damper, dan sesuai dengan penapis Damper dan Serbuk.

当接通电源时, Prefilter会自行折叠以压缩阻尼器, 并紧密贴合阻尼器和粉末过滤器。

When the power is switched off, Damper expands back to its original size and shakes off dust from Prefilter automatically with its expanding power.

Apabila kuasa dimatikan, Damper mengembang kembali ke saiz asalnya dan mengelakkan habuk dari Prefilter secara automatik dengan kuasa yang berkembang.

当电源关闭时, 阻尼器膨胀回到其原始尺寸, 并通过扩展的功率自动将Prefilter的灰尘抖落。



### VC3210L

173 W

#### Vacuum Cleaner (Wet & Dry)

Pembersih Vakum (Basah Dan Kering)  
吸尘器(干湿两用)

- For both wet and dry vacuum cleaning untuk menyedut kotoran kering atau lembap 适用于干和湿集尘清洁

Standard Equipment: Floor Nozzle, Corner Nozzle, Straight Pipe, Bent Pipe, Hose, Holder 10-33, Front Cuffs (22, 24, 38), Cloth Filter, Damper, Poly Bag Set (10pcs)



Continuous Rating Input Kuasa Sedutan 额定输入功率	1,050W
Max Peak Air Flow Aliran Udara 最大空气流量	2.0m <sup>3</sup> /min
Max Sealed Suction (water column) Sedutan Terkedap (Turus Air) 最大密封吸力(水柱)	22.0kPa (2,240 mmH <sub>2</sub> O)
Tank Capacity Kapasiti 容量	Dust: 32L Water: 27L
Dimensions (L x W x H) Dimensi 体积	552x398x685mm (21-3/4"x15-5/8"x27")
Net Weight Berat Bersih 净重	14.5kg (32.0lbs)
Power Supply Cord Kabel Wayar 电源线	5.0m (16.4ft)

### VC2510L

173 W

#### Vacuum Cleaner (Wet & Dry)

Pembersih Vakum (Basah Dan Kering)  
吸尘器(干湿两用)

- For both wet and dry vacuum cleaning untuk menyedut samaada kotoran kering atau lembap 适用于干和湿集尘清洁

Standard Equipment: Hose, Holder 10-33, Front Cuffs (22, 24, 38), Poly Bag, Poly Bag Set 10pcs



Continuous Rating Input Kuasa Sedutan 额定输入功率	1,050W
Max Peak Air Flow Aliran Udara 最大空气流量	2.0m <sup>3</sup> /min
Max Sealed Suction (water column) Sedutan Terkedap (Turus Air) 最大密封吸力(水柱)	22.0kPa (2,240 mmH <sub>2</sub> O)
Tank Capacity Kapasiti 容量	Dust: 25L Water: 14L
Dimensions (L x W x H) Dimensi 体积	432x416x451mm (17"x16-3/8"x17-3/4")
Net Weight Berat Bersih 净重	10.5kg (23.2lbs)
Power Supply Cord Kabel Wayar 电源线	5.0m (16.4ft)

### VC1310LX1

173 W

#### Vacuum Cleaner (Wet & Dry)

Pembersih Vakum (Basah Dan Kering)  
吸尘器(干湿两用)

- For both wet and dry vacuum cleaning untuk menyedut samaada kotoran kering atau lembap 适用于干和湿集尘清洁

Standard Equipment: Hose, Holder 10-33, Front Cuffs (22, 24, 38), Poly Bag Set, Cleaning Set



Continuous Rating Input Kuasa Sedutan 额定输入功率	1,050W
Max Peak Air Flow Aliran Udara 最大空气流量	2.0m <sup>3</sup> /min
Max Sealed Suction (water column) Sedutan Terkedap (Turus Air) 最大密封吸力(水柱)	22.0kPa (2,240 mmH <sub>2</sub> O)
Tank Capacity Kapasiti 容量	Dust: 13L Water: 7L
Dimensions (L x W x H) Dimensi 体积	366x334x420mm (14-3/8"x13-1/8"x16-1/2")
Net Weight Berat Bersih 净重	9.6kg (21.2lbs)
Power Supply Cord Kabel Wayar 电源线	5.0m (16.4ft)

Cordless  
Turret Head 炮台式

LED Flashlight  
Lampu Cahaya LED  
LED照明灯

Vacuum Cleaner  
Pembersih Vakum  
吸尘器

Drilling / Fastening  
Ganjal / Pengikat  
钻杆 / 螺帽

Impact Drilling / Demolition  
Ganjal / Pencah  
打桩钻杆 / 拆墙加工

Cutting / Penunjang  
切刀 / 螺帽

Grinding / Sanding  
Pengkilat / Pasikan  
打磨 / 砂磨

Sawing / Pengkilat  
锯切 / 螺帽

Planing / Routing  
Pengkilat / Tengking  
刨削 / 螺帽

Others  
Lain-lain  
其他

Outdoor Power Equipment  
Alatan Kuasa Luar  
园具 / 户外

Makita  
MAKITA

# Filter & Dust bag



for Dust  
(Powder)

























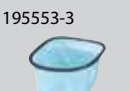
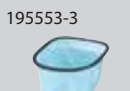

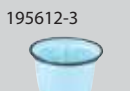

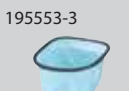
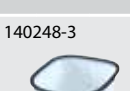
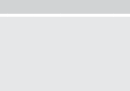
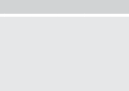
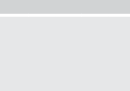
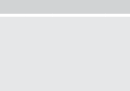
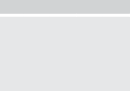
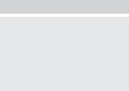
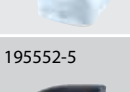
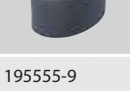





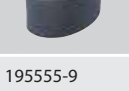

- Powder Filter Set
- Damper set
- Pre-filter set
- Dust paper filter or Poly bag set

Compatible with usual Poly bags or Paper filters, allowing for:

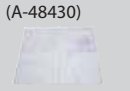

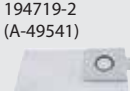
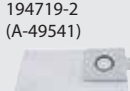
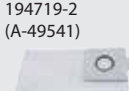
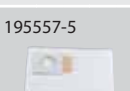
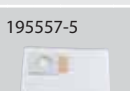
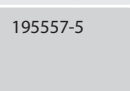
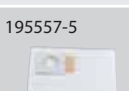
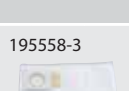
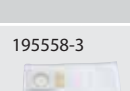
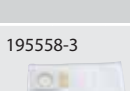
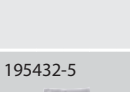
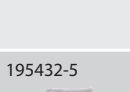
- Quick and easy dust disposal
- Lower-running cost compared with paper dust bag

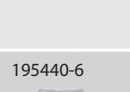
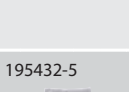

	DVC862L DVC860L	DVC864L DVC863L DVC861L	VC3211H	VC3211M VC2211M VC2201M	VC3210L	VC2510L	VC1310L
	 (Wet & Dry)	 (Dry)	 (Wet & Dry)	 (Wet & Dry)	 (Wet & Dry)	 (Wet & Dry)	 (Wet & Dry)
Powder Filter Set Dry only	*197166-6 	*197166-6 	196251-2 	196252-0 	195441-4 	195441-4 	195438-3 
*HEPA filter							
Pre-filter set	195553-3 	195553-3 	196253-8 	196253-8 	195612-3 	195554-1 	195553-3 
Cloth filter	140248-3 						
Damper set	195552-5 	195552-5 	196254-6 	196254-6 	195552-5 	195552-5 	195552-5 
Filter for water set Water only	195555-9 				195611-5 	195556-7 	195555-9 
Paper filter set (5pcs) for dry dust except powder	194556-4 (A-48430) 	194556-4 (A-48430) 					194556-4 (A-48430) 
Dust paper filter 7L (5pcs) for dry powder	194719-2 (A-49541) 	194719-2 (A-49541) 					194719-2 (A-49541) 
Filter bag set 15L (5pcs) for dry dust	195557-5 	195557-5 				195557-5 	195557-5 
Filter bag set 25L (5pcs) for dry dust			195558-3 	195558-3 	195558-3 		
Poly bag set (10pcs)	195432-5 	195432-5 	195440-6 	195440-6 	195440-6 	195440-6 	195432-5 

Cordless  
Tempat Akademi

LED Flashlight  
Lampu Saku LED  
LED30000

Vacuum Cleaner  
Pembersih Vakuum  
真空吸尘器

Drilling / Fastening  
Gergaji / Pengikat  
钻头 / 紧固件

Impact Drilling / Demolition  
Gergaji / Perusak  
打桩机 / 拆除机

Cutting  
Pemotong  
切割机

Grinding / Sanding  
Pemoles / Pasir  
打磨 / 砂磨

Sawing  
Gergaji  
锯切

Planing / Routing  
Pencap / Tenggam  
刨削 / 雕刻

Others  
Lain-lain  
其他

Outdoor Power Equipment  
Alat-alat Listrik  
户外电源设备



# Vacuum Cleaner System charts

Hose connection  
28mm

Hose connection  
38mm

Hose connection  
32mm

## For Cleaning

Model  
DVC860L  
DVC861L  
DVC862L  
DVC863L  
DVC864L



Model  
DVC340  
DVC350



Model  
DVC261  
DVC265



Model  
VC3211H  
VC3211M  
VC2211M  
VC3210L  
VC2510L  
VC1310L



Model  
CL121D



Model  
DVC750L



38-A Hose 38mm  
with front sleeve



32-A Hose 32mm  
with front sleeve



28-A Hose 28mm



28-B Bending pipe assembly



28-B Bending pipe assembly



28-H Flexible rubber nozzle



Front cuffs 22



Joint 38



28-C Aluminum Telescopic pipe assembly



28-C Plastic Telescopic pipe assembly



28-I Tapered nozzle set

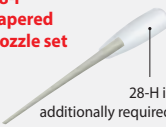

28-H is additionally required

28-I Tapered nozzle set



28-C Plastic Telescopic pipe assembly



28-D Nozzle assembly



28-E Round brush



28-F Corner nozzle



28-G Shelf brush



## For Dust Collecting

Model  
DVC860L  
DVC861L  
DVC862L  
DVC863L  
DVC864L



Model  
DVC340  
DVC350



Model  
DVC261  
DVC265



Model  
VC3211H  
VC3211M  
VC2211M  
VC3210L  
VC2510L  
VC1310L



Model  
DVC750L



28-A Hose 28mm



38-A Hose 38mm



Front cuffs 38, 22



Joint 22-38



Joint 22-38



Attachments



Cordless  
Tanpa Kabel Listrik

LED Flashlight  
Lampu Senter LED  
LED 照灯

Vacuum Cleaner  
Penyerap Vakum  
吸尘器

Drilling / Fastening  
Ganjal / Pengikat  
钻 / 固定

Impact Drilling / Demolition  
Ganjal / Perusak  
打桩 / 拆除加工

Cutting  
Pemotong  
切割

Grinding / Sanding  
Pengkil / Pasir  
打磨 / 砂磨

Sawing  
Gergaji  
锯切

Planing / Routing  
Pengkil / Tenggang  
刨 / 修边

Others  
Lain-lain  
其他

Outdoor Power Equipment  
Alat-alat Listrik  
园机 / 户外

Makita

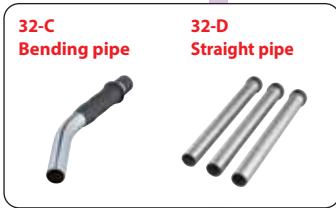
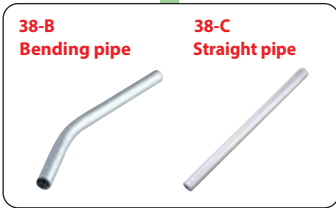

## Front cuffs, Joint & Hose Connection

**28-A Hose 28mm**

Supplied with both Front cuffs 22 and 38

Rear cuffs (free)

Front cuffs 38: Inner dia. 38.0mm, Outer dia. 44.2mm

Front cuffs 22: Inner dia. 22.4mm, Outer dia. 25.0mm

**38-A Hose 38mm**

Front cuffs 38

Rear cuffs (free)

Front cuffs 38: Inner dia. 38.0mm, Outer dia. 44.2mm

**Front cuffs 38, Front cuffs 22 and Front cuffs 24 connection**

28-A Hose 28 with Front cuffs 22

28-A Hose 28 with Front cuffs 38

38-A Hose 38 with Front cuffs 38

Front cuffs 24

**Hose to hose connection**

28-A Hose 28 with Front cuffs 38

38-A Hose 38 with Front cuffs 38

28-A Hose 28 Rear cuffs

38-A Hose 38 Rear cuffs

**Joint 22-38 connection & size**

38-A Hose with Front cuffs 38

Joint 22-38

Size: Inner dia. 22.4mm, Outer dia. 25.0mm

Cordless  
Tapekord 10.8V

LED Flashlight  
Lampu Senter LED  
LED 3000LM

Vacuum Cleaner  
Pembersih Vakuum  
10.8V

Drilling / Fastening  
Gardu / Pengikat  
Bor / Pasang

Impact Drilling / Demolition  
Gardu / Penorek  
Bor / Pasang / Demolisi

Cutting  
Pemotong  
Gergaji

Grinding / Sanding  
Pengkilan / Pasukan  
Bor / Pasang

Sawing  
Gergaji  
Gergaji

Planing / Routing  
Pengkilan / Tenggang  
Bor / Pasang

Others  
Lain-lain  
Bor

Outdoor Power Equipment  
Alat-alat Tenaga Listrik  
Bor / Pasang

**Makita**  
100% ORIGINAL

# System charts

Cordless  
Turret Head System

LED Flashlight  
Lampu Sinar LED  
LED照灯

Vacuum Cleaner  
Penjerap Vakum  
吸尘器

Drilling / Fastening  
Drooi / Pengebati  
钻孔 / 紧固

Impact Drilling / Demolition  
Drooi / Pengebati  
冲击钻孔 / 拆除加工

Cutting  
Pemotongan  
切割

Grinding / Sanding  
Pengamiran / Polesan  
打磨 / 砂磨

















Sawing  
Dempul  
锯切



Planing / Routing  
Pengamiran / Pengaliran  
刨削 / 雕刻



Others  
Lain-lain  
其他

Outdoor Power Equipment  
Alat-alat Listrik  
户外动力设备

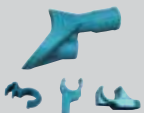
Makita  
19147











<p><b>A</b></p>  <p><b>W/ Ø28mm Hose</b></p> <p>Model VC3211H VC3211M VC2211M VC3210L</p> <p><b>W/ Front cuffs</b></p>  <p>38 24 22</p>	<p><b>B</b></p>  <p><b>W/ Ø28mm Hose</b></p> <p>Model VC2510L VC1310L DVC861L DVC863L DVC864L</p> <p><b>W/ Front cuffs</b></p>  <p>38 24 22</p>	<p><b>C</b></p>  <p><b>W/ Ø28mm Hose</b></p> <p>Model DVC350</p> <p><b>W/ Front cuffs</b></p>  <p>38 24 22</p>	<p><b>D</b></p>  <p><b>W/ Ø38mm Hose</b></p> <p>Model DVC860L DVC861L DVC862L DVC863L DVC750L</p> <p><b>W/ Joint 22-38</b></p> 	<p><b>E</b></p>  <p><b>W/ Ø28mm Hose</b></p> <p>Model DVC261 DVC265</p> <p><b>W/ Front cuffs</b></p>  <p>38 24 22</p>	<p><b>F</b></p>  <p><b>W/ Ø32mm Hose</b></p> <p>Model VC2012L VC2512L VC3011L</p> <p><b>W/ Tool adapter 24</b></p>  <p>P-81745</p> <p><b>Adapter 38 (option)</b></p>  <p>P-70421</p>	<p><b>G</b></p>  <p><b>W/ Ø32mm Hose</b></p> <p>Model VC3012L VC4010L VC3012M VC4010M</p> <p><b>W/ Tool adapter 24</b></p>  <p>P-70378</p> <p><b>38</b></p>  <p>W107418688</p>
---	---	--	---	---	---	---

For Model	Suction Systems and Part No.
<p><b>Rotary Hammer, Demolition Hammer</b> SDS-MAX, 17mm (11/16") Hex: Bull points with over 280mm length Cold chisels with over 280mm length</p> <p><b>SDS-MAX only:</b> Scaling chisel (for tile), Bushing tool Scaling chisels length</p> <p><b>19mm (3/4") Hex only</b> Scaling chisels</p> <p><b>17mm(11/16")Hex:</b> HM0830,HR3530, HR4030C</p> <p><b>SDS-MAX:</b> HR4001C/02/10C/11C, HR4501C/10C/11C, HR3540C/41FC HM0870C/71C, HM1101C/11C, HM1203C/13C, HM1214C HR4501C/10C/11C, HR4013C HR4003C, HR3540C/41FC DHR400, HR5202C, HR5212C, HM1205</p> <p><b>19mm(3/4")Hex:</b> HR4041C</p>	<p><b>Dust extractor attachment set</b> (Hammering mode only) 199144-2 (w/hose for) 199143-4 (w/o hose for)</p>  <p>ø28mm hose can be directly connected.</p> <p><b>A</b> Directly</p> <p><b>B</b> Directly</p> <p><b>C</b> Directly</p> <p><b>D</b> ø28mm hose</p> <p><b>E</b> Directly</p> <p><b>F</b> Tool adapter 24</p> <p><b>G</b> Tool adapter 24</p>
<p><b>Electric Breaker</b> HM1304/B, HM1306, HM1317C/CB, HM1307C/CB, HM1400, HM1500/B, HM1810, HM1801, HM1812, HM1802</p>  <p>197168-2 (w/o hose for) 197148-8 (w/ hose for)</p> <p>ø28mm hose can be directly connected.</p>	<p><b>Vacuum attachment set</b></p>  <p>197168-2 (w/o hose for) 197148-8 (w/ hose for)</p> <p>ø28mm hose can be directly connected.</p>

For Model	Suction Systems and Part No.
<p><b>Rotary Hammer, Combination Hammer</b> see page 150</p> <p>DHR242, HR2650, HR2651, HR2652, HR2653, HR2661, HR2663, DHR280, DHR282, HR2300, HR2600, HR2601, HR2601F, HR2630, HR2631F, HR2641 DHR243, HR2651T, HR2653T, HR2300T, HR2320T, HR2630T, HR2631FT,</p> <p>DHR164, DHR165, DHR171, DHR182, HR140D, HR166D, HR1840, HR1841F, HR2800, HR2810, HR2811F, DHR202, DHR241, DHR263, HR2230, HR2460, HR2460F, HR2470, HR2475</p> <p><b>Rotary Hammer, Combination Hammer</b> DHR164, DHR165 DHR202, BHR262/T DHR263, DHR264</p> <p>HR2470 series HR2800 series</p>	<p><b>Dust cup set</b> 195173-3</p>  <p><b>Dust extractor attachment</b> 193472-7</p>  <p><b>Vacuum attachment</b></p> <p>195866-2</p>  <p>(Max. Bit Diameter 40mm)</p> <p>199142-6 196858-4</p>
<p><b>A</b> Front cuffs 22</p> <p><b>B</b> Front cuffs 22</p> <p><b>C</b> Front cuffs 22</p> <p><b>D</b> Joint 22-38 195548-6</p> <p><b>E</b> Front cuffs 22</p> <p><b>F</b> Tool adapter + Joint 25-50 192349-3</p> <p><b>G</b> Tool adapter 38 + Joint 22-38 195548-6</p>	<p><b>A</b> Front cuffs 22</p> <p><b>B</b> Front cuffs 22</p> <p><b>C</b> Front cuffs 22</p> <p><b>D</b> Joint 22-38 195548-6</p> <p><b>E</b> Front cuffs 22</p> <p><b>F</b> Tool adapter + Joint 25-50 192349-3</p> <p><b>G</b> Tool adapter 38 + Joint 22-38 195548-6</p>



# System charts

For Model	Suction Systems and Part No.
<b>Angle Cutter</b> 4112H 4112HS 4114 4114S 	<b>Elbow joint 32</b> 192613-2 
<b>Dustless Cutter</b> 4105KB 	<b>Elbow joint 32</b> 192613-2 
<b>Dustless Cutter</b> 4100KB 	
<b>Cutter With Dust Collection</b> 4157KB 	
<b>Wall Chaser</b> SG1251, SG1250 	
<b>Concrete Planer</b> PC5000C, PC5001C PC5010C 	
<b>Angle Grinder</b> For 115, 125mm Model Single notch ——— w/o mark of origin 195237-3 Triple notches w/o mark of origin for IEC 195239-9 w/ mark of origin for IEC 195238-1 North America package 195236-5 North America package for UL 196575-6 For 180,230mm Model w/ mark of origin for IEC 195384-0 w/o mark of origin for IEC 195385-8 North America package for UL 197584-8 Twin notches w/ mark of origin 195387-4 w/o mark of origin 195388-2 North America package 195386-6 	<b>Dust collecting wheel guard</b> For cup type diamond wheel 

**A**

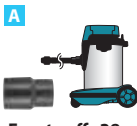

**Front cuffs 38**

**B**

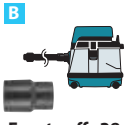

**Front cuffs 38**

**C**



**Front cuffs 38**

**D**



**Front cuffs 38**

**E**



**Front cuffs 38**

**F**

















**Adapter 38**

**G**



**Tool adapter 38**

For Model	Suction Systems and Part No.
<b>Angle Grinder</b> For 125mm Model ——— 196845-3 196846-1 	<b>Dust collecting wheel guard</b> 
<b>Angle Grinder</b> For 230mm Model ——— 198379-2 198380-7 	
<b>Angle Grinder</b> For 115, 125mm Model ——— 192968-5 193794-5 (Economy type) For 180mm Model ——— 194303-3 For 230mm Model ——— 194044-1 	<b>Dust collecting wheel guard</b> 
<b>Belt Sander</b> 9924DB 	<b>Joint 32</b> 192518-6 
<b>Belt Sander</b> 9404, 9902, 9903, 9910, 9911, 9920, 	
<b>Belt Sander</b> 9403, 9921 	<b>Joint 32</b> 192349-3 
<b>Wheel Sander</b> 9741 	<b>Joint</b> 410899-9 

**A**

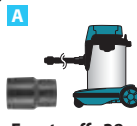

**Front cuffs 38**

**B**



**Front cuffs 38**

**C**



**Front cuffs 38**

**D**



**Front cuffs 38**

**E**



**Front cuffs 38**

**F**



**Adapter 38**

**G**



**Tool adapter 38**



Cordless  
Tegap Kord / 無線

LED Flashlight  
Lampu Suluh LED  
LED 照度灯

Vacuum Cleaner  
Pembersih Vakuum  
吸尘器

Drilling / Fastening  
Gergaji / Pengikat  
锯 / 固定

Impact Drilling / Demolition  
Gergaji / Pemecah  
打桩机 / 拆除机

Cutting  
Pemotong  
切割机

Grinding / Sanding  
Pergilas / Pasir  
打磨 / 砂磨

Sawing  
Gergaji  
锯切

Planing / Routing  
Perhalan / Tenggam  
刨 / 修边

















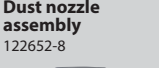

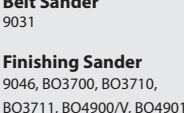

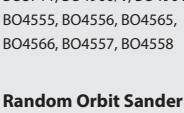

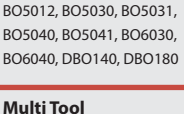
Others  
Lain-lain  
其他

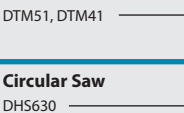
Outdoor Power Equipment  
Alat-alat Kerdil Luar  
户外动力设备

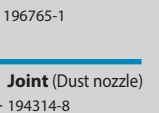











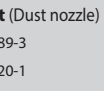

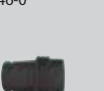

**Makita**  
1915

# System charts

Cordless  
Turret Head Style  
LED Flashlight  
Lampu Samping LED  
LED 照灯  
Vacuum Cleaner  
Penyerap Vakum  
吸尘器  
Drilling / Fastening  
Drool / Pengikat  
钻孔 / 紧固  
Impact Drilling / Demolition  
Drool / Perusak  
冲击钻孔 / 拆除加工  
Cutting  
Pemotongan  
切割  
Grinding / Sanding  
Pengkilan / Pasir  
打磨 / 砂磨  
Sawing  
Gergaji  
锯切  
Planing / Routing  
Penghalan / Tenggang  
刨削 / 雕刻  
Others  
Lain-lain  
其他  
Outdoor Power Equipment  
Alat-alat Listrik  
园机 / 户外

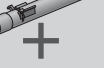
For Model	Suction Systems and Part No.
<b>Disc Grinder</b> N9500N, 9500NB 	<b>Dust collecting wheel guard</b> 192212-0  <b>Rubber sleeve</b> 192202-3 
<b>Angle Grinder</b> For 100mm Model  For 115,125mm Model 	<b>Dust collecting wheel guard</b> Dust collecting 100C set — 198413-8 Dust collecting 100CD set — 198414-6  198415-4 
<b>Belt Sander</b> 9032 	<b>Dust nozzle assembly</b> 122652-8 
<b>Belt Sander</b> 9031 	
<b>Finishing Sander</b> 9046, BO3700, BO3710, BO3711, BO4900/V, BO4901, BO4555, BO4556, BO4565, BO4566, BO4557, BO4558 	
<b>Random Orbit Sander</b> BO5012, BO5030, BO5031, BO5040, BO5041, BO6030, BO6040, DBO140, DBO180 	
<b>Multi Tool</b> DTM50, DTM40 — 195965-0 TM3000C — 196022-7 TM3010C — 196550-2  DTM51, DTM41 — 196765-1 	<b>Dust attachment set</b>  196765-1 
<b>Circular Saw</b> DHS630 — 194314-8 DSS611, DSS610 — 419283-5 DSS501, DSS500 — 194415-2 HS300D, HS301D — 195334-5 	<b>Joint (Dust nozzle)</b> 
<b>Jig Saw</b> JV100D, JV143D, JV183D, 4326, 4327, 4328, 4329, JV0600 	
<b>Jig Saw</b> DJV140, DJV180, 4350T/CT/FCT, 4351T/CT/FCT 	<b>Dust Nozzle</b> 417853-4 



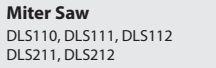
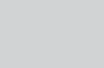

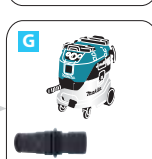
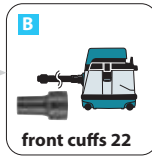



For Model	Suction Systems and Part No.
	<b>front cuffs 24</b> 195546-0 
<b>Circular Saw</b> HS6100, HS6101, HS7100, HS7101 — 453289-3 DHS710, HS6600, HS6601, HS7010, HS7600, HS7601, HS7610, HS7611 — 196520-1 HS6600, HS7000, HS7600, DHS711 — 196843-7 (with short lever) 5007N, 5007NF — 199712-1 (with short lever) HS0600 — 198263-1 DHS680 — 198265-7 (with short lever) 196961-1 196952-2 (with short lever) HS7000, HS7600 — 196520-1 197221-4 (with short lever)	<b>Joint (Dust nozzle)</b> 453289-3 
	<b>Front cuffs 24</b> 195546-0 
<b>Plunge Cut Circular Saw</b> SP6000 	<b>Front cuffs 24</b> 195546-0 
<b>Cordless Plunge Cut Circular Saw</b> DSP600, DSP601 	
<b>Aluminum Groove Cutter</b> CA5000 	
<b>Cordless Jig Saw</b> DJV141, DJV142, DJV181, DJV182, DJV102D, JV103D — 457801-1 	<b>Dust nozzle assembly</b> 126331-0  <b>Front cuffs 24</b> 195546-0 
<b>Slide Compound Saw</b> LS1019/L, LS1219/L 	<b>Front cuffs 24</b> 195546-0 
<b>Cordless Slide Compound Miter Saw</b> DLS110, DLS111, DLS112, DLS211, DLS212 	



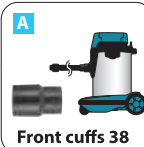





\* not needed  
Front cuffs 24

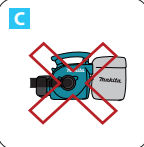

# System charts

For Model	Suction Systems and Part No.
<b>Cordless Slide Compound Miter Saw</b> DLS713 DLS714	 <p><b>A</b> Front cuffs 38</p>
<b>Slide Compound Saw</b> LS0714/F/FL/L LS0815F/FL LS1016L LS1017L LS1018/L LS1216/L	 <p><b>B</b> Front cuffs 38</p>
<b>Miter Saw</b> LS1030N, LS1440	 <p><b>C</b> Front cuffs 38</p>
<b>Compound Miter Saw</b> LS1040/F, LS1045, LS1221	 <p><b>D</b> Front cuffs 38</p>
<b>Cordless Compound Miter Saw</b> DLS600	 <p><b>E</b></p>
<b>Flip Over Saw</b> LF1000	 <p><b>F</b> Adapter 38</p>
<b>Table Top Miter Saw</b> LH1040/F LH1201FL	 <p><b>G</b> Tool adapter 38</p>

For Model	Suction Systems and Part No.	
<b>Table Saw</b> 2704N, 2705	<b>Joint</b> 419093-0	 <p><b>A</b> Front cuffs 38</p>
<b>Table Saw</b> 2703	<b>Joint 55</b> 192799-2	 <p><b>B</b> Front cuffs 38</p>
<b>Table Saw</b> MLT100N	<b>Dust point</b> JM27000090	 <p><b>C</b></p>
<b>Table Saw</b> 2712		 <p><b>D</b> Front cuffs 38</p>
<b>Table Saw</b> 2712		 <p><b>E</b></p>
<b>Band Saw</b> LB1200F	<b>Joint</b> 419093-0	 <p><b>F</b> Adapter 38</p>
		 <p><b>G</b> Tool adapter 38</p>



Cordless  
Tegak Kord 00.00.00

LED Flashlight  
Lampu Suluh LED  
LEDM000003

Vacuum Cleaner  
Pembersih Vakuum  
00.00.00

Drilling / Fastening  
Gergaji / Pengikat  
00.00.00

Impact Drilling / Demolition  
Gergaji / Perseki  
00.00.00

Cutting  
Pemotong  
00.00.00

Grinding / Sanding  
Pemoles / Pasir  
00.00.00

Sawing  
Gergaji  
00.00.00

Planing / Routing  
Pemoles / Tenggam  
00.00.00

Others  
Lain-lain  
00.00.00

Outdoor Power Equipment  
Alat-alat Listrik Luar  
00.00.00

**Makita**  
100% MADE IN JAPAN

# System charts

Cordless  
Turret Head 角磨机

LED Flashlight  
Lampu Senter LED  
LED 手电筒

Vacuum Cleaner  
Pembersih Vakum  
吸尘器

Drilling / Fastening  
Ganda / Pengikat  
钻、紧固

Impact Drilling / Demolition  
Ganda / Perusak  
钻、拆、砸

Cutting  
Pemotong  
切割

Grinding / Sanding  
Pengkilan / Pasir  
打磨、砂磨









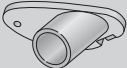

Sawing  
Gergaji  
锯切

Planing / Routing  
Pengaliran / Tenggam  
刨、修边













Others  
Lain-lain  
其他

Outdoor Power Equipment  
Alat-alat Listrik  
户外电力设备

Makita  
MAKITA

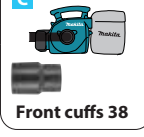
For Model	Suction Systems and Part No.
<b>Circular Saw</b> 5603R, 5704R, 5705R 5143R 5008MG 5103R, 5903R 5104S, 5104 N5900B, 5902B	<b>Joint (Dust nozzle)</b> 192420-3 192490-2 450079-5 194489-3 (with short lever) 192419-8 450316-7 193823-9 193068-4 (with short lever)
	
<b>Circular Saw</b> 5604R, 5037NB	
<b>Dustless Circular Saw</b> 5017RKB 5057KB	
	<p><b>A</b>  <b>Front cuffs 38</b></p> <p><b>B</b>  <b>Front cuffs 38</b></p> <p><b>C*</b>  <b>Front cuffs 38</b></p> <p><b>D</b>  <b>Front cuffs 38</b></p> <p><b>E</b>  <b>Front cuffs 38</b></p> <p><b>F</b>  <b>Adapter 38</b></p> <p><b>G</b>  <b>Tool adapter 38</b></p>

**\*C: DVC350, DVC340 Cannot be used with Planer models**

For Model	Suction Systems and Part No.
<b>Power Planer</b> 1050D, 1051D KP0810/C	
<b>Power Planer</b> DKP180, DKP140 KP0800	<b>Nozzle</b> 451329-1
	
1805N	JPA122277
<b>Power Planer</b> 1911B	<b>Nozzle for vacuum cleaner</b> 192082-7
	
<b>Power Planer</b> N1900B, N1923B, KP0800, 1804N 1805N, 1806B, KP312/S	
	<p><b>A</b>  <b>Front cuffs 38</b></p> <p><b>B</b>  <b>Front cuffs 38</b></p> <p><b>C*</b>  <b>Front cuffs 38</b></p> <p><b>D</b>  <b>Front cuffs 38</b></p> <p><b>E</b>  <b>Front cuffs 38</b></p> <p><b>F</b>  <b>Adapter 38</b></p> <p><b>G</b>  <b>Tool adapter 38</b></p>

**\*C: DVC350, DVC340 Cannot be used with Planer models**



## Nozzle assembly



## Joint

\*Elbow







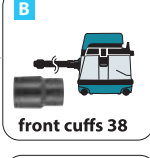

Model No.	Part No.	Model No.	Part No.
N1900B, N1923B	181572-5	N1900B, N1923B	JPA122275 (122275-2)
KP0800, DKP180, DKP140	451329-1	DKP180, DKP140, KP0810/ C, KP0800	*416368-8
1804N	JPA122278 (122278-6)		
1805N	JPA122277 (122277-6)		
1806B	122397-8	1804N, 1805N, 1806B, KP312/S	181575-9
KP312/S	193733-5		

# System charts

For Model	Suction Systems and Part No.
<b>Plate Joiner</b> PJ7000, 3901, DPJ180, DPJ140	 <p><b>A</b> front cuffs 22</p>
<b>Cut-out Tool</b> 3706	 <p><b>B</b> front cuffs 22</p>
<b>Dust collection cover</b> 193449-2	 <p><b>C*</b> front cuffs 22</p>
<b>Cordless Cut-out Tool</b> DCO180	 <p><b>D</b> Joint 22-38 195548-6</p>
<b>Cordless Drywall saw</b> DSD180, SD100D	 <p><b>E</b> front cuffs 22</p>
<b>Router</b> RP0910, RP1110C	 <p><b>F</b> Tool adapter 24 + Joint 25-50 192349-3</p>
	 <p><b>G</b> Tool adapter 38 + Joint 22-38 195548-6</p>

\*C: DVC350 Cannot be used with Router models

For Model	Suction Systems and Part No.
<b>Router</b> RP1801/ F RP1800/ F RP2301FC RP2300FC	<b>Dust nozzle</b> 194934-8
 <p><b>A</b> front cuffs 38</p>	 <p><b>B</b> front cuffs 38</p>
<b>Router</b> RD1100, RD1101, RF1100, RF1101, RP1100, RP1101	<b>Dust nozzle</b> 193379-7
 <p><b>C</b> front cuffs 38</p>	 <p><b>D</b></p>
<b>Router</b> RP0900, ***RT0700C, DRT50	<b>Dust nozzle</b> 194733-8
<b>Cordless Router</b> DRT50	 <p><b>E</b> front cuffs 38</p>
*** Use with Plunge base assembly	 <p><b>F</b> Adapter 38</p>
<b>Trimmer</b> RT0700C	<b>Dust nozzle</b> 195559-1
<b>Cordless Trimmer</b> DRT50	 <p><b>G</b> Tool adapter 38</p>

Makita recommend to use 38mm hose when you use Router



Cordless  
Tegak Kord 18V Li-Ion

LED Flashlight  
Lampu Suluah LED  
LEGB03B03

Vacuum Cleaner  
Pembersih Vakuum  
18V Li-Ion

Drilling / Fastening  
Gergaji / Pengikat  
18V Li-Ion

Impact Drilling / Demolition  
Gergaji / Pemecah  
18V Li-Ion

Cutting  
Pemotong  
18V Li-Ion

Grinding / Sanding  
Pergasi / Pasir  
18V Li-Ion

Sawing  
Gergaji  
18V Li-Ion

Planing / Routing  
Pergasi / Tunggam  
18V Li-Ion

Others  
Lain-lain  
18V Li-Ion

Outdoor Power Equipment  
Alat-alat Kerdil Luar  
18V Li-Ion

Makita  
18V Li-Ion

Cordless  
Turret Head 角磨机

LED Flashlight  
Lampu Senter LED  
LED 手电筒

Vacuum Cleaner  
Pembersih Vakum  
吸尘器

Drilling / Fastening  
Ganda / Pengikat  
钻、紧固

Impact Drilling / Demolition  
Ganda / Perusak  
冲击钻、拆除加工

Cutting  
Pemotong  
切割

Grinding / Sanding  
Pengkilan / Pasir  
打磨 / 砂磨

Sawing  
Gergaji  
锯切

Planing / Routing  
Pengaliran / Pengaliran  
刨削 / 雕刻

Others  
Lain-lain  
其他

Outdoor Power Equipment  
Alat-alat Listrik  
户外动力设备

Makita  
MAKITA

### Front cuffs & Joint

Front cuffs 22



Front cuffs 24



Front cuffs 38



Joint 22-38



Joint 38



Joint H



Rubber sleeve 18-21



Type	Part No.
Front cuffs 22	195547-8
Front cuffs 24	195546-0
Front cuffs 38	195545-2
Joint 22-38	195548-6
Joint 38	418500-0
Joint H	424009-2
Rubber sleeve 18-21	192202-3

### Hose connection 28mm

#### 28-A

#### Hose

Note:

Can be connected with power tools, Front cuffs and Joint are required for some power tools.

\*DVC260, DVC261, DVC265 only

\*for cleaning (Use with Bending pipe assembly)



Size	Length (m)	with Front cuffs	Part No.
28mm	1.0	-	*143787-2
28mm	1.5	-	*144408-9
28mm	1.5	38	*152992-0
28mm	1.5	22, 38	A-34235
28mm	2.5	22, 24, 38	195437-5
28mm	3.5	22, 24, 38	195433-3
28mm	5	22, 24, 38	195436-7
28mm	5	22, 38	A-34229

### Hose connection 32mm

#### 32-A

#### Hose 32mm

for cleaning

Use with 28-B Bending pipe assembly



Size	Length (m)	with Front cuffs	Part No.
32mm	1.0	Sleeve	199453-9
32mm	1.7	Sleeve	199493-7

### 28-B

#### Bending pipe

\*with Hose 28 sleeve



Description	Part No.
For Aluminum (Part No. 140G19-0) Telescopic pipe assembly with lock	140G26-3
	*127093-3
For plastic straight pipe 28 and Telescopic pipe assembly 28	458184-2
	*126756-8

### 28-C

#### Straight pipe



Description	Part No.	EU
		Part No.
Aluminum Telescopic pipe assembly Pipe length is variably adjustable from 590 to 942mm.	140G19-0	-
Telescopic pipe assembly 28 Pipe length is variably adjustable from 500 to 850mm.	198559-0	198560-5

### 28-D

#### Nozzle assembly

Flat type



F/C switching t-nozzle 28  
Flooring & carpet

Floor/carpet t-nozzle  
For rug / carpet cleaning

For rug / carpet cleaning

Floor t-nozzle 28

Seat nozzle 28  
For car seat

Description	Color	Part No.	EU
			Part No.
Flat type	Black	199454-7	-
F/C switching t-nozzle 28 Flooring & carpet	White	198183-9	198532-0
Floor/carpet t-nozzle For rug / carpet cleaning	White	198525-7	198528-1
	Black	198526-5	198529-9
For rug / carpet cleaning	Ivory	122291-4	-
Floor t-nozzle 28	White	123486-2	-
Seat nozzle 28 For car seat	White	199037-3	199038-1
	Black	198921-9	199039-9

## 28-E Round brush



Color	Part No.	EU
		Part No.
White	198877-6	198878-4
Black	198551-6	198555-8

## 28-F Corner nozzle

Type	Color	Part No.	EU
			Part No.
300-28mm	White	198918-8	198919-6
	Black	198991-8	198992-6
Crevice nozzle 415 set	White	199439-3	-

## 28-G Shelf brush

(For gentle cleaning by soft-tipped brush)



Color	Part No.	EU
		Part No.
White	198872-6	198873-4
Black	198536-2	198540-1

## 28-H Flexible rubber nozzle



Color	Part No.	EU
		Part No.
Gray	197900-4	197901-2

## 28-I Tapered nozzle set

Use with Front cutts 22 or Flexible rubber nozzle



Color	Part No.	EU
		Part No.
gray	192236-6	198558-2

## Hose stand

For model  
VC2510L



Part No.  
197323-6

## Holder set 10-33



Part No.  
195544-4

## Holder cuff set



Components	Part No.
Holder 10-33, Front cuff 24, Front cuff 22	195637-7



Cordless  
Tapekord 18V Li-Ion

LED Flashlight  
Lampu Saku LED  
LED 18V Li-Ion

Vacuum Cleaner  
Pembersih Vakuum  
18V Li-Ion

Drilling / Fastening  
Gergaji / Pengikat  
Batang / Pasak

Impact Drilling / Demolition  
Gergaji / Pemecah  
Batang / Pasak

Cutting  
Pemotong  
Gergaji

Grinding / Sanding  
Pengkilan / Pasukan  
Batang / Pasak

Sawing  
Gergaji  
Batang / Pasak

Planing / Routing  
Pengkilan / Pengkilan  
Batang / Pasak

Others  
Lain-lain  
Batang / Pasak

Outdoor Power Equipment  
Alat-alat Tenaga Listrik  
Batang / Pasak

Makita  
18V Li-Ion

Cordless  
Turret Head 手枪式

LED Flashlight  
Lampu Senter LED  
LED 手电筒

Vacuum Cleaner  
Penyedot Vakum  
吸尘器

Drilling / Fastening  
Gardu / Pasengat  
钻孔 / 紧固

Impact Drilling / Demolition  
Gardu / Persekol  
冲击钻孔 / 拆除加工

Cutting  
Pemotongan  
切割

Grinding / Sanding  
Pengkilan / Pasikan  
打磨 / 砂磨

Sawing  
Dempul  
锯切

Planing / Routing  
Pergalan / Tenggam  
刨削 / 雕刻

Others  
Lain-lain  
其他

Outdoor Power Equipment  
Alat-alat Tenaga Listrik  
园林·户外



### Hose connection 38mm

#### 38-A

#### Hose 38mm

for cleaning

\*Use with 28-B Bending pipe assembly



Size	Length (m)	with Front cuffs	Part No.
38mm	1.5	-	*199388-4
38mm	1.5	38	198757-6
38mm	2.5	38	195434-1
38mm	5	38	195435-9

### Cleaning set

Includes one each of:

- Hose complete 38-2.5
- Straight pipe
- Bending pipe
- Nozzle assembly
- Corner nozzle



Part No.
195439-1

### 38-B

#### Bending pipe



Description	Part No.
Aluminum	192562-3

### 38-C

#### Straight pipe



Description	Part No.
Aluminum	192563-1

### 38-D

#### Nozzle assembly

Flat type



Flooring & carpet

Universal Type

Compact Type A

Compact Type B  
(wet model only)

Wide Type  
(wet model only)

Description	Dry/ Wet	Part No.	EU
			Part No.
Flat type	Dry	199455-5	
Flooring & carpet	Dry	198184-7	198533-8
Universal Type	Dry/ Wet	195551-7	-
Compact Type A	Dry	195549-4	122334-2
Compact Type B	Wet	195550-9	122335-0
Wide Type	Wet	A-47846	-

### 38-E

#### Round brush



Type	Color	Part No.	EU
			Part No.
38mm	Black	191657-9	-

### 38-F

#### Corner nozzle



Type	Color	Part No.
38mm	Yellow gray	410306-2



# DRILLING FASTENING

Penggerudian | Mengetat 钻孔 | 紧固



## DF0300 10mm (3/8")

411

### Driver Drill

Gerudi Pemutar Skru  
螺丝起子电钻



- **Compact Design with a Short Overall Length**  
Reka bentuk padat dan pendek  
紧凑小巧的设计

Standard Equipment: (+)(-) Bit



<b>Continuous Rating Input</b> Input Kuasa Berterusan 额定输入功率	320W
<b>Capacity</b> Kapasiti 能力	Steel: 10mm (3/8")   Wood: 28mm (1-1/8")
<b>Chuck Capacity</b> Kapasiti Chuck 夹头能力	1.0 - 10mm (1/32 - 3/8")
<b>No Load Speed (RPM)</b> Kelajuan Tanpa Beban 回转数	High: 0 - 1,500   Low: 0 - 450
<b>Max Fastening Torque</b> Tenaga Pemutaran Pengancing Maksimum 最快扭转	Hard 56.0N-m (500in.lbs.) Soft: 21.0N-m (190in.lbs.)
<b>Max Lock Torque</b> Pemutaran Tenaga Maksimum 最大锁定扭力	42.0N-m (370in.lbs.)
<b>Dimensions (L x W x H)</b> Dimensi 体积	220x67x206mm (8-5/8"x2-5/8"x8-1/8")
<b>Net Weight</b> Berat Bersih 净重	1.2kg (2.7lbs.)
<b>Power Supply Cord</b> Kabel Wayar 电源线	2.5m (8.2ft)

## DP2010 6.5mm (1/4")

419

### High Speed Drill

Gerudi Kelajuan Tinggi  
高速钻



- **Compact and high power**  
Kuasa tinggi dan padat  
紧凑和高功率

Standard Equipment: Chuck Key



<b>Continuous Rating Input</b> Input Kuasa Berterusan 额定输入功率	370W
<b>Capacity</b> Kapasiti 能力	Steel: 6.5mm (1/4") Wood: 15mm (9/16")
<b>No Load Speed (RPM)</b> Kelajuan Tanpa Beban 回转数	0-4,200
<b>Dimensions (L x W x H)</b> Dimensi 体积	209x64x175mm (8-1/4"x2-1/2"x6-7/8")
<b>Net Weight</b> Berat Bersih 净重	1.0kg (2.2lbs.)
<b>Power Supply Cord</b> Kabel Wayar 电源线	2.0m (6.6ft)

## 6305 13mm (1/2")

303

### Drill

Gerudi  
电钻



- **Heavy duty motor**  
Motor tugas berat unggul  
卓越马达

Standard Equipment: Chuck Key, Depth Gauge, Side Grip



<b>Continuous Rating Input</b> Input Kuasa Berterusan 额定输入功率	850W
<b>Capacity</b> Kapasiti 能力	Steel: 13mm (1/2") Wood: 30mm (1-3/16")
<b>No Load Speed (RPM)</b> Kelajuan Tanpa Beban 回转数	1,450
<b>Dimensions (L x W x H)</b> Dimensi 体积	346x84x152mm (13-5/8"x3-5/16"x6")
<b>Net Weight</b> Berat Bersih 净重	2.8kg (6.2lbs.)
<b>Power Supply Cord</b> Kabel Wayar 电源线	2.5m (8.2ft)

## 6413 10mm (3/8")

64

### Drill

Gerudi  
电钻



- **General Purpose Drill Featuring Compact And Lightweight Design**  
Reka Bentuk Kompak Dan Ringan untuk penggerudian tujuan umum  
紧凑轻巧机身适合一般用途



<b>Continuous Rating Input</b> Input Kuasa Berterusan 额定输入功率	450W
<b>Capacity</b> Kapasiti 能力	Steel: 10mm (3/8") Wood: 25mm (1")
<b>No Load Speed (RPM)</b> Kelajuan Tanpa Beban 回转数	0-3,400
<b>Dimensions (L x W x H)</b> Dimensi 体积	234x64x183mm (9-1/4"x2-1/2"x7-1/4")
<b>Net Weight</b> Berat Bersih 净重	1.3kg (2.9lbs)
<b>Power Supply Cord</b> Kabel Wayar 电源线	2.0m (6.6ft)

Cordless  
Tangki Akad 充电式

LED Flashlight  
Lampu Suhu LED  
LED照明灯

Vacuum Cleaner  
Pembersih Vakuum  
吸尘器

Drilling / Fastening  
Gerudi / Pengangat  
钻孔 / 紧固

Impact Drilling / Demolition  
Gerudi / Penebuk  
石工钻孔 / 拆墙施工

Cutting  
Pemotong  
切割

Grinding / Sanding  
Pengamiran / Pemoles  
打磨 / 砂磨

Sawing  
Gergaji  
锯切

Planing / Routing  
Pengaliran / Tunggam  
刨削 / 雕刻

Others  
Lain-lain  
其他

Outdoor Power Equipment  
Alatan Kuasa Luar  
户外动力工具

Makita  
MAKITA

# DRILLING | FASTENING

Cordless  
Tangki Akumulator

LED Flashlight  
Lampu Bawah LED  
LED 照明灯

Vacuum Cleaner  
Pembersih Vakuum  
吸尘器

Drilling / Fastening  
Gergaji / Pengikat  
电钻 / 螺帽

Impact Drilling / Demolition  
Gerudi / Pemecah  
起工钻 / 砸墙加工

Cutting  
Pemotong  
切割

Grinding / Sanding  
Penggosok / Pelekan  
磨削 / 砂磨

Sawing  
Gergaji  
锯切

Planing / Routing  
Pengaliran / Tanggapan  
刨削 / 雕刻

Others  
Lain-lain  
其他

Outdoor Power Equipment  
Alat-alat Kerja Luar  
园机 / 户外

Makita  
19157



## DS5000 16mm (5/8")

411

**Drill**  
Gerudi  
电钻



- **Powerful 750W motor for improved mixing and drilling performance**  
Motor berkuasa 750W untuk prestasi pencampuran dan penggerudian yang lebih baik  
强劲的750W马达提高混合和钻孔性能



Standard Equipment: Chuck Key, Top Grip



<b>Continuous Rating Input</b> Input Kuasa Berterusan 额定输入功率	750W
<b>Capacity</b> Kapasiti 能力	Steel: 16mm (5/8") Wood: 36mm (1-7/16")
<b>No Load Speed (RPM)</b> Kelajuan Tanpa Beban 回转数	600
<b>Dimensions (L x W x H)</b> Dimensi 体积	348x83x401mm (13-3/4"x3-1/4"x15-3/4")
<b>Net Weight</b> Berat Bersih 净重	3.0kg (6.6lbs)
<b>Power Supply Cord</b> Kabel Wayar 电源线	2.5m (8.2ft)

## DS4012 13mm (1/2")

411

**Drill**  
Gerudi  
电钻



- **All-ball bearing construction for durability and longer tool life**  
Struktur gelas bola untuk memanjangkan hayat alat  
滚珠轴承结构延长工具寿命



Standard Equipment: Chuck Key, Top Grip



<b>Continuous Rating Input</b> Input Kuasa Berterusan 额定输入功率	750W
<b>Capacity</b> Kapasiti 能力	Steel: 13mm (1/2") Wood: 36mm (1-7/16")
<b>No Load Speed (RPM)</b> Kelajuan Tanpa Beban 回转数	0-600
<b>Dimensions (L x W x H)</b> Dimensi 体积	340x83x390mm (13-3/8"x3-1/4"x15-3/8")
<b>Net Weight</b> Berat Bersih 净重	2.8kg (6.2lbs)
<b>Power Supply Cord</b> Kabel Wayar 电源线	2.5m (8.2ft)

## 6016 16mm (5/8")

51

**Drill**  
Gerudi  
电钻

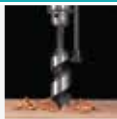

- **D-handle rotates 360 degrees for multi-position operation**  
Pemegang-D berputar 360° memudahkan operasi  
360° 旋转D型手柄方便操作



Standard Equipment: Chuck Key, Depth Gauge, Top Grip

<b>Continuous rating input</b> Input Kuasa Berterusan 额定输入功率	480W
<b>Capacity</b> Kapasiti 能力	Steel: 16mm (5/8") Wood: 36mm (1-3/8")
<b>No Load Speed (RPM)</b> Kelajuan Tanpa Beban 回转数	700
<b>Overall Length</b> Panjang Keseluruhan 总长度	365mm (14-3/8")
<b>Net weight</b> Berat Bersih 净重	4.4kg (9.7lbs)
<b>Power supply cord</b> Kabel Wayar 电源线	2.5m (8.2ft)

# DRILLING | FASTENING

## DA3010F 10mm (3/8")

419

### Angle Drill Gerudi Sudut 角向电钻



- **Powerful 450W motor with less weight**  
Motor berkuasa 450W dan ringan  
轻量且强劲的450W马达

Standard Equipment: Chuck Key, Side grip 36 complete



<b>Continuous Rating Input</b> Input Kuasa Berterusan 额定输入功率	450W
<b>Capacity</b> Kapasiti 能力	Steel: 10mm (3/8") Wood: 25mm (1")
<b>No Load Speed (RPM)</b> Kelajuan Tanpa Beban 回转数	0-2,400
<b>Overall Length</b> Panjang Keseluruhan 总长度	270mm (10-5/8")
<b>Net Weight</b> Berat Bersih 净重	1.6kg (3.5lbs)
<b>Power Supply Cord</b> Kabel Wayar 电源线	2.5m (8.2ft)

## TD0100

419

### Impact Driver Pemutar Skru Impak 冲击螺丝起子机



- **Impacting mechanism for secure fastening**  
Mekanisme impak untuk pengetatan yang kukuh  
冲击机构确保紧固

Standard Equipment: Phillips Bit



<b>Continuous rating input</b> Input Kuasa Berterusan 额定输入功率	230W
<b>Capacity</b> Kapasiti 能力	Machine Screw: M4 - M8 (5/32" - 5/16") Standard Bolt: M5 - M14 (3/16" - 9/16") High Tensile Bolt: M5 - M10 (3/16" - 3/8") Coarse thread (in length): 22 - 90mm (7/8" - 3-1/2")
<b>Driving Shank (Hex)</b> Hex Memandu Aci 六角驱动轴	6.35mm (1/4")
<b>Impacts Per Minute (IPM)</b> Impak Per Minit 冲击数	0 - 3,200
<b>No Load Speed (RPM)</b> Kelajuan Tanpa Beban 回转数	0 - 3,600
<b>Max Fastening Torque</b> Maksimum Tenaga Pemutaran Pengancing 最快扭力	100N-m (74ft.lbs.)
<b>Dimensions (L x W x H)</b> Dimensi 体积	218x60x180mm (8-5/8"x2-3/8"x7-1/8")
<b>Net weight</b> Berat Bersih 净重	0.96kg (2.1lbs)
<b>Power supply cord</b> Kabel Wayar 电源线	2.5m (8.2ft)

## TD0101F

411

### Impact Driver Pemutar Skru Impak 冲击螺丝起子机



- **Enables to drive screws even without pre-drilling pilot holes**  
Skru boleh digerudi walaupun tanpa lubang pra-penggerudian  
即使没有预钻导孔也可以驱动螺钉

Standard Equipment: Phillips Bit



<b>Continuous rating input</b> Input Kuasa Berterusan 额定输入功率	230W
<b>Capacity</b> Kapasiti 能力	Machine Screw: M4 - M8 (5/32" - 5/16") Standard Bolt: M5 - M14 (3/16" - 9/16") High Tensile Bolt: M5 - M10 (3/16" - 3/8") Coarse thread (in length): 22 - 90mm (7/8" - 3-1/2")
<b>Driving Shank (Hex)</b> Hex Memandu Aci 六角驱动轴	6.35mm (1/4")
<b>Impacts Per Minute (IPM)</b> Impak Per Minit 冲击数	0 - 3,200
<b>No Load Speed (RPM)</b> Kelajuan Tanpa Beban 回转数	0 - 3,600
<b>Max Fastening Torque</b> Maksimum Tenaga Pemutaran Pengancing 最快扭力	100N-m (74ft.lbs.)
<b>Dimensions (L x W x H)</b> Dimensi 体积	184x67x192mm (7-1/4"x2-5/8"x7-9/16")
<b>Net weight</b> Berat Bersih 净重	0.99kg (2.2lbs)
<b>Power supply cord</b> Kabel Wayar 电源线	2.5m (8.2ft)

## FS2300

419

### Drywall Screwdriver Pemutar Skru Drywall 石膏板螺丝起子机



- **Large trigger with lock-on button for operator convenience**  
Butang pencetus dengan fungsi mengunci untuk memudahkan pengguna  
备有锁定功能的触发按钮方便操作

Standard Equipment: Phillips Insert Bit x2, Magnetic Bit Holder



<b>Continuous Rating Input</b> Input Kuasa Berterusan 额定输入功率	570W
<b>Capacity</b> Kapasiti 能力	Drywall Screw: 5mm (3/16") Self-Drilling Screw: 6mm (1/4")
<b>Driving Shank (Hex)</b> Hex Memandu Aci 六角驱动轴	6.35mm (1/4")
<b>No Load Speed (RPM)</b> Kelajuan Tanpa Beban 回转数	0 - 2,500
<b>Dimensions (L x W x H)</b> Dimensi 体积	290x70x207mm (11-3/8"x2-3/4"x8-1/8")
<b>Net Weight</b> Berat Bersih 净重	1.6kg (3.5lbs)
<b>Power Supply Cord</b> Kabel Wayar 电源线	2.5m (8.2ft.)

## FS2500

419

### Screwdriver Pemutar Skru 螺丝起子机



- **Aluminum gear housing for less weight and increased durability**  
Lebih tahan lama dan ringan dengan gear aluminium  
铝合金齿轮更轻更耐用

Standard Equipment: Magnetic Socket Bit



<b>Continuous Rating Input</b> Input Kuasa Berterusan 额定输入功率	570W
<b>Capacity</b> Kapasiti 能力	Drywall Screw: 5mm (3/16") Self-Drilling Screw: 6mm (1/4")
<b>Driving Shank (Hex)</b> Hex Memandu Aci 六角驱动轴	6.35mm (1/4")
<b>No Load Speed (RPM)</b> Kelajuan Tanpa Beban 回转数	0 - 2,500
<b>Dimensions (L x W x H)</b> Dimensi 体积	280x70x207mm (11"x2-3/4"x8-1/8")
<b>Net Weight</b> Berat Bersih 净重	1.5kg (3.4lbs)
<b>Power Supply Cord</b> Kabel Wayar 电源线	2.5m (8.2ft.)

Cordless  
Tangkas Kord 无线电钻LED Flashlight  
Lampu Suhu LED  
LED照明灯Vacuum Cleaner  
Penembuh Vakuum  
吸尘器Drilling / Fastening  
Gerudi / Pengancing  
钻孔 / 紧固Impact Drilling / Demolition  
Gerudi / Penembuh  
冲击钻孔 / 拆墙施工Cutting  
Pemotong  
切割Grinding / Sanding  
Pengamiran / Pemoles  
研磨 / 砂磨Sawing / Routing  
Gergaji  
锯切Planing / Router  
Pengalasan / Tunggaman  
刨削 / 磨床Others  
Lain-lain  
其他Outdoor Power Equipment  
Alatan Kuasa Luar  
户外动力设备Makita  
MAKITA

# Drilling | Fastening

Cordless  
Tangan Keras 无绳式

LED Flashlight  
Lampu Sulu LED  
LED 照明灯

Vacuum Cleaner  
Pembersih Vakum  
吸尘器

Drilling / Fastening  
Gergaji / Paseng  
钻孔 / 紧固

Impact Drilling / Demolition  
Gergaji / Persekol  
起工钻孔 / 拆除加工

Cutting  
Pemotong  
切割

Grinding / Sanding  
Pengamiran / Pasiran  
磨削 / 打磨

Sawing  
Gergaji  
锯切

Planing / Routing  
Pengaliran / Tanggapan  
刨削 / 磨削

Others  
Lain-lain  
其他

Outdoor Power Equipment  
Alatan Kerja Luar  
园机-户外



## FS2700

419 W

**Screwdriver**  
Pemutar Skru  
螺丝起子机



- 6 stage adjustable torque adjustment for a wide range of applications  
6 tahap pelarasan tork untuk pelbagai aplikasi  
6级扭力调节适合各种应用



<b>Continuous Rating Input</b> Input Kuasa Berterusan 额定输入功率	570W
<b>Capacity</b> Kapasiti 能力	Self-Drilling Screw: 6mm (1/4") Machine Screw: 8mm (5/16") Wood Screw: 6.2mm (1/4")
<b>Driving Shank (Hex)</b> Hex Memandu Aci 六角驱动轴	6.35mm (1/4")
<b>No Load Speed (RPM)</b> Kelajuan Tanpa Beban 回转速数	0 - 2,500
<b>Dimensions (L x W x H)</b> Dimensi 体积	301x70x207mm (11-7/8"x2-3/4"x8-1/8")
<b>Net Weight</b> Berat Bersih 净重	1.8kg (4lbs)
<b>Power Supply Cord</b> Kabel Wayar 电源线	2.5m (8.2ft.)

## FS4200

419 W

**Drywall Screwdriver**  
Pemutar Skru Papan Gypsum  
石膏板螺丝起子机



- Powerful 570W motor  
Motor berkuasa 570W  
570W 强力马达

Standard Equipment: Phillips Insert Bit x2, Magnetic Bit Holder



<b>Continuous Rating Input</b> Input Kuasa Berterusan 额定输入功率	570W
<b>Capacity</b> Kapasiti 能力	Drywall Screw: 5mm (3/16") Self-Drilling Screw: 6mm (1/4") 6.35mm (1/4")
<b>Driving Shank (Hex)</b> Hex Memandu Aci 六角驱动轴	6.35mm (1/4")
<b>No Load Speed (RPM)</b> Kelajuan Tanpa Beban 回转速数	0 - 4,000
<b>Dimensions (L x W x H)</b> Dimensi 体积	269x65x207mm (10-5/8"x2-9/16"x8-1/8")
<b>Net Weight</b> Berat Bersih 净重	1.4kg (3lbs)
<b>Power Supply Cord</b> Kabel Wayar 电源线	2.5m (8.2ft.)

## FS6300

419 W

**Drywall Screwdriver**  
Pemutar Skru Papan Gypsum  
石膏板螺丝起子机



- Silent clutch for improved performance and durability  
Klacc senyap untuk prestasi dan ketahanan yang lebih baik  
静音离合器提高性能和耐用性

Standard Equipment: Phillips Insert Bit x2, Magnetic Bit Holder



<b>Continuous Rating Input</b> Input Kuasa Berterusan 额定输入功率	570W
<b>Capacity</b> Kapasiti 能力	Drywall Screw: 4mm (5/32")
<b>Driving Shank (Hex)</b> Hex Memandu Aci 六角驱动轴	6.35mm (1/4")
<b>No Load Speed (RPM)</b> Kelajuan Tanpa Beban 回转速数	0 - 6,000
<b>Dimensions (L x W x H)</b> Dimensi 体积	279x65x207mm (11"x2-9/16"x8-1/8")
<b>Net Weight</b> Berat Bersih 净重	1.4kg (3.1lbs)
<b>Power Supply Cord</b> Kabel Wayar 电源线	2.5m (8.2ft.)



# DRILLING | FASTENING

## UT1305

303 mm

### Mixer

Pengadun  
搅拌机



- Heavy duty and high speed mixer  
Tahan lasak dan kelajuan tinggi  
耐用和高速

Standard Equipment: Wrenches, Side Grip, Blade



<b>Continuous Rating Input</b> Input Kuasa Berterusan 额定输入功率	850W
<b>Blade Diameter</b> Diameter Bilah 锯片直径	165mm (6-1/2")
<b>No Load Speed (RPM)</b> Kelajuan Tanpa Beban 回转数	1,300
<b>Shank Size of Tool Holder Portion</b> Batang Saiz 柄部尺寸	M12
<b>Dimensions (L x W x H)</b> Dimensi 体积	942x87x152mm (37"x3-7/16"x6")
<b>Net Weight</b> Berat Bersih 净重	2.6kg (5.7lbs)
<b>Power Supply Cord</b> Kabel Wayar 电源线	2.5m (8.2ft)

## UT2204

303 mm

### Mixer

Pengadun  
搅拌机



- Heavy duty and high speed mixer  
Tahan lasak dan kelajuan tinggi  
耐用和高速

Standard Equipment: Wrenches, Side Grip



<b>Continuous rating input</b> Input Kuasa Berterusan 额定输入功率	850W
<b>Blade Diameter</b> Diameter Bilah 锯片直径	220mm (8-5/8")
<b>No Load Speed (RPM)</b> Kelajuan Tanpa Beban 回转数	550
<b>Shank Size of Tool Holder Portion</b> Batang Saiz 柄部尺寸	M12 or M14
<b>Dimensions (L x W x H)</b> Dimensi 体积	929x89x152mm (36-1/2"x3-1/2"x6")
<b>Net weight</b> Berat Bersih 净重	2.7kg (5.9lbs)
<b>Power supply cord</b> Kabel Wayar 电源线	2.5m (8.2ft)

## TW1000 25.4mm (1")

153 mm

### Impact Wrench

Perengkuh Impak  
套筒扳手



- Huge 1,000N·m (738 ft.lbs.) of Power for Industrial Applications  
Kuasa 1,000N·m (738 ft.lbs.) untuk aplikasi perindustrian  
巨大的 1,000N·m (738 ft.lbs.) 功率适合工业应用

Standard Equipment: Side Grip, Socket



<b>Continuous Rating Input</b> Input Kuasa Berterusan 额定输入功率	1,200W
<b>Fastening Capacities</b> Kapasiti 能力	Standard Bolt: M24 - M30 (15/16" - 1-3/16") High Tensile Bolt: M22 - M24 (7/8" - 15/16")
<b>Square Drive</b> Batang Segi Empat 四方头	25.4mm (1")
<b>No Load Speed (RPM)</b> Kelajuan Tanpa Beban 回转数	1,400
<b>Impacts Per Minute (IPM)</b> Impak Per Minit 冲击数	1,500
<b>Max Fastening Torque</b> Maksimum Tenaga Pemutaran Pengancing 最快扭力	1,000N·m (738ft.lbs.)
<b>Dimensions (L x W x H)</b> Dimensi 体积	382x110x290mm (15"x4-5/16"x11-3/8")
<b>Net Weight</b> Berat Bersih 净重	8.8kg (19.4lbs)
<b>Power Supply Cord</b> Kabel Wayar 电源线	2.5m (8.2ft)

## 6906 19mm (3/4")

100 mm

### Impact Wrench

Perengkuh Impak  
套筒扳手



- Powerful 850W motor  
Motor berkuasa 850W  
强大的850W马达

Standard Equipment: Side Grip, Socket



<b>Continuous Rating Input</b> Input Kuasa Berterusan 额定输入功率	850W
<b>Capacity</b> Kapasiti 能力	Standard Bolt: M16 - M22 (5/8" - 7/8") High Tensile Bolt: M16 - M20 (5/8" - 3/4")
<b>Square Drive</b> Batang Segi Empat 四方头	19mm (3/4")
<b>No Load Speed (RPM)</b> Kelajuan Tanpa Beban 回转数	1,700
<b>Impacts Per Minute (IPM)</b> Impak Per Minit 冲击数	1,600
<b>Max Fastening Torque</b> Maksimum Tenaga Pemutaran Pengancing 最快扭力	588 N·m (441ft.lbs.)
<b>Overall Length</b> Dimensi 体积	327mm (12-7/8")
<b>Net Weight</b> Berat Bersih 净重	5.6kg (12.2lbs)
<b>Power Supply Cord</b> Kabel Wayar 电源线	2.5m (8.2ft)

## 6905B 12.7mm (1/2")

65 mm

### Impact Wrench

Perengkuh Impak  
套筒扳手



- Aluminum hammer case with high durability  
Casing aluminium yang bertahan  
铝制外壳更耐用

Standard Equipment: Socket 19, 22, 24



<b>Continuous Rating Input</b> Input Kuasa Berterusan 额定输入功率	440W
<b>Fastening Capacities</b> Kapasiti 能力	Standard Bolt: M12 - M20 (1/2" - 3/4") High Tensile Bolt: M12 - M16 (1/2" - 5/8")
<b>Square Drive</b> Batang Segi Empat 四方头	12.7mm (1/2")
<b>No Load Speed (RPM)</b> Kelajuan Tanpa Beban 回转数	1,700
<b>Impacts Per Minute (IPM)</b> Impak Per Minit 冲击数	2,000
<b>Max Fastening Torque</b> Maksimum Tenaga Pemutaran Pengancing 最快扭力	294N·m (217ft.lbs.)
<b>Overall Length</b> Dimensi 体积	270mm (10-5/8")
<b>Net Weight</b> Berat Bersih 净重	2.8kg (6.2lbs)
<b>Power Supply Cord</b> Kabel Wayar 电源线	2.5m (8.2ft)

Cordless  
Tanggap Kord 无绳电

LED Flashlight  
Lampu Suhu LED  
LED照明灯

Vacuum Cleaner  
Pembersih Vakuum  
吸尘器

Drilling / Fastening  
Garu / Pengancing  
钻孔 / 紧固

Impact Drilling / Demolition  
Garu / Peneh  
冲击钻孔 / 拆除

Cutting  
Pemotong  
切割

Grinding / Sanding  
Pengisar / Poles  
研磨 / 砂磨

Sawing  
Gergaji  
锯切

Planing / Routing  
Pengaliran / Tergam  
刨削 / 雕刻

Others  
Lain-lain  
其他

Outdoor Power Equipment  
Alatan Kuasa Luar  
户外动力设备

Makita  
Makita

# Drilling | Fastening

## TW0350 12.7mm (1/2")

411 WATT

### Impact Wrench Perengkuh Impak 套筒扳手



- **Large, efficient hammer creates more impacts for greater power**  
Penukuk kecekapan tinggi untuk hentaman yang lebih kuat  
高效率锤子给予更强的冲击力

Standard Equipment: Socket



<b>Continuous Rating Input</b> Input Kuasa Berterusan 额定输入功率	400W
<b>Fastening Capacities</b> Kapasiti 能力	<b>Standard Bolt:</b> M12 - M22 (1/2" - 7/8") <b>High Tensile Bolt:</b> M12 - M16 (1/2" - 5/8") 12.7mm (1/2")
<b>Square Drive</b> Batang Segi Empat 四方头	
<b>No Load Speed (RPM)</b> Kelajuan Tanpa Beban 回转数	2,000
<b>Impacts Per Minute (IPM)</b> Impak Per Minit 冲击数	2,000
<b>Max Fastening Torque</b> Maksimum Tenaga Pemutaran Pengancing 最快扭力	350N-m (260ft.lbs.)
<b>Dimensions (L x W x H)</b> Dimensi 体积	283x87x233mm (11-1/8"x3-7/16"x9-1/8")
<b>Net Weight</b> Berat Bersih 淨重	3kg (6.6lbs)
<b>Power Supply Cord</b> Kabel Wayar 电源线	2.5m (8.2ft)

## TW0200 12.7mm (1/2")

411 WATT

### Impact Wrench Perengkuh Impak 套筒扳手



- **Compact and lightweight design for use in tight spaces**  
Sesuai untuk digunakan di ruang kecil  
方便用于小空间

Standard Equipment: Socket, Hook



<b>Continuous Rating Input</b> Input Kuasa Berterusan 额定输入功率	380W
<b>Fastening Capacities</b> Kapasiti 能力	<b>Standard Bolt:</b> M10 - M16 (3/8" - 5/8") <b>High Tensile Bolt:</b> M10 - M12 (3/8" - 1/2") 12.7mm (1/2")
<b>Square Drive</b> Batang Segi Empat 四方头	
<b>No Load Speed (RPM)</b> Kelajuan Tanpa Beban 回转数	0 - 2,200
<b>Impacts Per Minute (IPM)</b> Impak Per Minit 冲击数	0 - 2,200
<b>Max Fastening Torque</b> Maksimum Tenaga Pemutaran Pengancing 最快扭力	200N-m (150ft.lbs.)
<b>Dimensions (L x W x H)</b> Dimensi 体积	251x72x220mm (9-7/8"x2-13/16"x8-5/8")
<b>Net Weight</b> Berat Bersih 淨重	2.1kg (4.7lbs)
<b>Power Supply Cord</b> Kabel Wayar 电源线	2.5m (8.2ft)

## 6922NB M16 (5/8"), M20 (3/4"), M22 (7/8")

411 WATT

### Shear Wrench Perengkuh Ricih 扭断式套筒扳手



- **Compact and Lightweight Yet Powerful**  
Kompak dan ringan namun berkuasa  
小巧轻便功能强大

Standard Equipment: Screwdriver, Sleeve M20, Sleeve M24



<b>Continuous Rating Input</b> Input Kuasa Berterusan 额定输入功率	1,330W
<b>Capacity</b> Kapasiti 能力	<b>Bolt :</b> M16, M20, M22 (5/8", 3/4", 7/8") 18
<b>No Load Speed (RPM)</b> Kelajuan Tanpa Beban 回转数	18
<b>Max Fastening Torque</b> Maksimum Tenaga Pemutaran Pengancing 最快扭力	804N-m (593ft.lbs.)
<b>Dimensions (L x W x H)</b> Dimensi 体积	249x84x252mm (9-13/16"x3-5/16"x9-15/16")
<b>Net Weight</b> Berat Bersih 淨重	4.9kg (10.8lbs)
<b>Power Supply Cord</b> Kabel Wayar 电源线	2.5m (8.2ft)

## 6924N M22 (7/8"), M24 (1"), SHTB22

303 WATT

### Shear Wrench Perengkuh Ricih 扭断式套筒扳手



- **High rotational speed for more efficient operation**  
Kelajuan putaran tinggi untuk operasi yang lebih cekap  
高转速提高操作效率

Standard Equipment: Screwdriver, Sleeve M24



<b>Continuous Rating Input</b> Input Kuasa Berterusan 额定输入功率	1,050W
<b>Capacity</b> Kapasiti 能力	<b>Bolt :</b> M22, M24, 7/8", 1" Super high tensile bolt : M22 19
<b>No Load Speed (RPM)</b> Kelajuan Tanpa Beban 回转数	19
<b>Max Fastening Torque</b> Maksimum Tenaga Pemutaran Pengancing 最快扭力	1,100N-m (810ft.lbs.)
<b>Dimensions (L x W x H)</b> Dimensi 体积	330x104x257mm (13"x4-1/8"x10-1/8")
<b>Net Weight</b> Berat Bersih 淨重	7.5kg (16.6lbs)
<b>Power Supply Cord</b> Kabel Wayar 电源线	2.5m (8.2ft)

## HB500 50mm (2")

### Magnetic Drill Gerudi Magnet 磁力钻孔机



- **Magnetic base, drill stand, and drill machine all in one package system**  
Dasar bermagnet, mesin dan penagak gerudi dalam satu sistem  
磁性底座, 钻架和钻机集在同一系统

Standard Equipment: Quick release arbor, Small oil cup assembly and clip, Safety guard, Polyester safety strap, Integral oil feed steady allen keys



<b>Capacity</b> Kapasiti 能力	Steel: 50mm (2")
<b>Chuck Capacity</b> Kapasiti Chuck 夹头能力	16mm (5/8")
<b>No Load Speed (RPM)</b> Kelajuan Tanpa Beban 回转数	350 / 650
<b>Magnetic Clamping Force</b> Kekuatan Penjepit Magnetik 磁力夹紧力	Minimum 9,300N (950kg)
<b>Dimensions (L x W x H)</b> Dimensi 体积	290x150x450mm (11-3/8"x5-7/8"x17-3/4")
<b>Net Weight</b> Berat Bersih 淨重	18.5kg (40.8lbs)

Cordless  
Tutupi Hood 防尘式

LED Flashlight  
Lampu Buluh LED  
LED 照明灯

Vacuum Cleaner  
Pembersih Vakuum  
吸尘器

Drilling / Fastening  
Gergaji / Pengikat  
钻孔 / 紧固

Impact Drilling / Demolition  
Gergaji / Perseki  
冲击钻孔 / 拆除加工

Cutting  
Pemotong  
切割

Grinding / Sanding  
Pengisar / Piskin  
研磨 / 打磨

Sawing  
Gergaji  
锯切

Planing / Routing  
Pengaliran / Tinggapan  
刨削 / 磨削

Others  
Lain-lain  
其他

Outdoor Power Equipment  
Alatan Kuasa Luar  
园具 / 户外

# IMPACT DRILLING DEMOLITION

Gerudi | Pemecah 石工钻孔 | 凿裂加工



## HP0300 10mm (3/8")

411

**Hammer Driver Drill**  
Tukul Pemutar Skru Bergerudi  
冲击螺丝起子电钻



- 2-mode operation for "Rotation Only" or "Hammering with Rotation"  
operasi 2 mod, penukulan dengan putaran atau hanya putaran  
2档模式变换, 旋转并锤击或仅旋转



Standard Equipment: (+)(-) Bit



<b>Continuous Rating Input</b> Input Kuasa Berterusan 额定输入功率	320W
<b>Capacity</b> Kapasiti 能力	Concrete: 8mm (5/16")   Steel: 10mm (3/8")   Wood: 28mm (1-1/8")
<b>Chuck Capacity</b> Kapasiti Chuck 夹头能力	1.0 - 10mm (1/32 - 3/8")
<b>Impacts Per Minute (IPM)</b> Impak Per Minit 冲击数	High: 0 - 22,500   Low: 0 - 6,750
<b>No Load Speed (RPM)</b> Kelajuan Tanpa Beban 回转速	High: 0 - 1,500   Low: 0 - 450
<b>Max Fastening Torque</b> Tenaga Pemutaran Pengancing Maksimum 最快扭转	Hard 56.0N-m (500in.lbs.) Soft: 21.0N-m (190in.lbs.)
<b>Max Lock Torque</b> Pemutaran Tenaga Maksimum 最大锁定扭力	42.0N-m (370in.lbs.)
<b>Dimensions (L x W x H)</b> Dimensi 体积	235x67x206mm (9-1/4"x2-5/8"x8-1/8")
<b>Net Weight</b> Berat Bersih 净重	1.3kg (2.8lbs.)
<b>Power Supply Cord</b> Kabel Wayar 电源线	2.5m (8.2ft)

## HP1230 12mm (15/32")

419

**Hammer Drill**  
Gerudi Tukul  
冲击电钻



- 2 operation modes - hammering with rotation and rotation only  
Operasi 2-Mod untuk Putaran Hanya atau Hammering with Rotation  
仅旋转或旋转锤击的双模式操作



Standard Equipment: Chuck Key, Depth Gauge, Side Grip



<b>Continuous Rating Input</b> Input Kuasa Berterusan 额定输入功率	400W
<b>Capacity</b> Kapasiti 能力	Concrete: 12mm (15/32")/ Steel: 10mm (3/8")/ Wood: 15mm (9/16")
<b>Chuck Capacity</b> Kapasiti Chuck 夹头能力	1.5 - 10mm (1/16 - 3/8")
<b>Impacts Per Minute (IPM)</b> Impak Per Minit 冲击数	0 - 31,900
<b>No Load Speed (RPM)</b> Kelajuan Tanpa Beban 回转速	0 - 2,900
<b>Dimensions (L x W x H)</b> Dimensi 体积	239x67x188mm (9-3/8"x2-5/8"x7-3/8")
<b>Net Weight</b> Berat Bersih 净重	1.7kg (3.7lbs.)
<b>Power Supply Cord</b> Kabel Wayar 电源线	2.0m (6.6ft)

## HP1630 16mm (5/8")

85

**Hammer Drill**  
Gerudi Tukul  
冲击电钻



- Lightweight with large drilling capacity up to 16mm in concrete  
Ringan dengan kapasiti penggerudian yang besar sehingga 16mm dalam konkrit  
轻量, 高能力, 混凝土钻孔达16mm



Standard Equipment: Side Handle, Chuck Key



<b>Continuous Rating Input</b> Input Kuasa Berterusan 额定输入功率	710W
<b>Capacity</b> Kapasiti 能力	Concrete: 16mm (5/8")/ Steel: 13mm (1/2")/ Wood: 30mm (1-3/16")
<b>No Load Speed (RPM)</b> Kelajuan Tanpa Beban 回转速	0 - 3,200
<b>Impacts Per Minute (IPM)</b> Impak Per Minit 冲击数	0 - 48,000
<b>Dimensions (L x W x H)</b> Dimensi 体积	296x75x204mm (11-5/8"x2-15/16"x8")
<b>Net Weight</b> Berat Bersih 净重	2.1kg (4.6lbs)
<b>Power Supply Cord</b> Kabel Wayar 电源线	2.0m (6.6ft)

Cordless  
Tapekod 充电式

LED Flashlight  
Lampu Suka LED  
LED照明灯

Vacuum Cleaner  
Pembersih Vakuam  
吸尘器

Drilling | Fastening  
Cepat | Pengikat  
钻孔 | 紧固

Impact Drilling | Demolition  
Gerudi | Pemecah  
石工钻孔 | 凿裂加工

Cutting  
Pemotong  
切割

Grinding | Sanding  
Pengkilan | Pasir  
打磨 | 砂磨

Sawing  
Cergas  
锯切

Planing | Routing  
Pegyalan | Tumpang  
刨平 | 榫嵌

Others  
Lain-lain  
其他

Outdoor Power Equipment  
Alatan Kuasa Luar  
户外动力设备

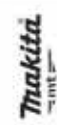

# IMPACT DRILLING | DEMOLITION

Cordless  
Tanpa Kabel Listrik

LED Flashlight  
Lampu Senter LED  
LED 照灯

Vacuum Cleaner  
Pembersih Vakuum  
吸尘器

Drilling | Fastening  
Drill / Pengikat  
钻孔 / 紧固

Impact Drilling | Demolition  
Drill / Pemecah  
冲击钻孔 / 拆除加工

Cutting  
Pemotongan  
切割

Grinding | Sanding  
Pengamiran / Polesan  
打磨 / 磨削

Sawing  
Gergaji  
锯切

Planing | Routing  
Pengaliran / Tergampan  
刨削 / 雕刻

Others  
Lain-lain  
其他

Outdoor Power Equipment  
Alat-alat Tenaga Listrik  
园林工具

Makita  
マキタ

## HP2050 20mm (3/4") 419 W

**2-Speed Hammer Drill**  
Gerudi Tukul  
冲击电钻



• **2-Mode operation for Rotation Only or Hammering with Rotation**  
Operasi 2-Mod untuk Putaran Hanya atau Hammering with Rotation  
仅旋转或旋转锤击的双模式操作

Standard Equipment: Chuck Key, Side Grip, Depth Rod



<b>Continuous Rating Input</b> Input Kuasa Berterusan 额定输入功率	720W
<b>Capacity</b> Kapasiti 能力	Concrete: 20mm (3/4")
	Steel Hi : 8mm (5/16") Steel Lo : 13mm (1/2") Wood Hi : 25mm (1") Wood Lo : 40mm (1-9/16")
<b>Impacts Per Minute (IPM)</b> Kelajuan Tanpa Beban 回转数	High: 0-58,000 Low: 0-24,000
<b>No Load Speed (RPM)</b> Impak Per Minit 冲击数	High: 0-2,900 Low: 0-1,200
<b>Overall Length</b> Panjang Keseluruhan 总长度	362mm (14-1/4")
<b>Net Weight</b> Berat Bersih 净重	2.5kg (5.6lbs)
<b>Power Supply Cord</b> Kabel Wayar 电源线	2.5m (8.2ft)

## HR1830 18mm (11/16") 419 W

**Rotary Hammer**  
Tukul Putar  
电锤



• **2-Mode operation for Rotation Only or Hammering with Rotation**  
Operasi 2-Mod untuk Putaran Hanya atau Hammering with Rotation  
仅旋转或旋转锤击的双模式操作

Standard Equipment: Side Grip, Depth Gauge



SELESAI stok, finish ada 售完即止  
**WHILE STOCK LAST**

<b>Continuous Rating Input</b> Input Kuasa Berterusan 额定输入功率	440W
<b>Impact Energy</b> Kekuatan Impak 单次最大锤击力	EPTA-Procedure 05/2009: 1.2J Our experimental conditions: 1.2J
<b>Capacity</b> Kapasiti 能力	Concrete: 18mm (11/16") Concrete (Diamond core bit) : 65mm (2-9/16") Steel: 13mm (1/2") Wood: 24mm (15/16")
<b>Impacts Per Minute (IPM)</b> Impak Per Minit 冲击数	0-5,000
<b>No Load Speed (RPM)</b> Kelajuan Tanpa Beban 回转数	0-1,500
<b>Dimensions (L x W x H)</b> Dimensi 体积	279x66x208mm (10-7/8"x2-5/8"x8-3/16")
<b>Net Weight</b> Berat Bersih 净重	1.9kg (4.2lbs)
<b>Power Supply Cord</b> Kabel Wayar 电源线	2.5m (8.2ft)

## HR1840 18mm (11/16") 459 W

**Rotary Hammer**  
Tukul Putar  
电锤



• **2-Mode operation for Rotation Only or Hammering with Rotation**  
Operasi 2-Mod untuk Putaran Hanya atau Hammering with Rotation  
仅旋转或旋转锤击的双模式操作

Standard Equipment: Side Grip, Depth Gauge



<b>Continuous Rating Input</b> Input Kuasa Berterusan 额定输入功率	470W
<b>Impact Energy</b> Kekuatan Impak 单次最大锤击力	EPTA-Procedure 05/2009: 1.4J Our experimental conditions: 1.4J
<b>Capacity</b> Kapasiti 能力	Concrete: 18mm (11/16") Core Bit: 35mm (1-3/8") Diamond Core Bit (Dry Type): 65mm (2-9/16") Steel: 13mm (1/2") Wood: 24mm (15/16")
<b>Impacts Per Minute (IPM)</b> Impak Per Minit 冲击数	0 - 4,800
<b>No Load Speed (RPM)</b> Kelajuan Tanpa Beban 回转数	0 - 2,100
<b>Dimensions (L x W x H)</b> Dimensi 体积	285x75x208mm (11-1/4"x3"x8-3/16")
<b>Net Weight</b> Berat Bersih 净重	2.0 - 2.4kg (4.3 - 5.3lbs)
<b>Power Supply Cord</b> Kabel Wayar 电源线	2.5m (8.2ft)

## HR1841F 18mm (11/16") 459 W

**Rotary Hammer**  
Tukul Putar  
电锤



• **2 operation modes - "Hammering with Rotation" and "Rotation" only**  
2 mod operasi - "Mengetuk dengan Putaran" dan "Putaran" sahaja  
2种操作模式 - "旋转锤击" 和 "旋转"

Standard Equipment: Side Grip, Depth Gauge



<b>Continuous Rating Input</b> Input Kuasa Berterusan 额定输入功率	470W
<b>Impact Energy</b> Kekuatan Impak 单次最大锤击力	EPTA-Procedure 05/2009: 1.4J Our experimental conditions: 1.4J
<b>Capacity</b> Kapasiti 能力	Concrete: 18mm (11/16") Core Bit: 35mm (1-3/8") Diamond Core Bit (Dry Type): 65mm (2-9/16") Steel: 13mm (1/2") Wood: 24mm (15/16")
<b>Impacts Per Minute (IPM)</b> Impak Per Minit 冲击数	0 - 4,800
<b>No Load Speed (RPM)</b> Kelajuan Tanpa Beban 回转数	0 - 2,100
<b>Dimensions (L x W x H)</b> Dimensi 体积	285x75x208mm (11-1/4"x3"x8-3/16")
<b>Net Weight</b> Berat Bersih 净重	2.0 - 2.5kg (4.5 - 5.4lbs)
<b>Power Supply Cord</b> Kabel Wayar 电源线	2.5m (8.2ft)

## HR2020 20mm (3/4") 419 W

**Rotary Hammer**  
Tukul Putar  
电锤



• **2-Mode operation for Rotation Only or Hammering with Rotation**  
Operasi 2-Mod untuk hanya putaran, penukulan dengan putaran sahaja  
仅旋转或旋转锤击的双模式操作

Standard Equipment: Side Grip, Depth Gauge



<b>Continuous Rating Input</b> Input Kuasa Berterusan 额定输入功率	710W
<b>Capacity</b> Kapasiti 能力	Concrete: 20mm (3/4") Steel: 13mm (1/2") Wood: 32mm (1-1/4")
<b>Impacts Per Minute (IPM)</b> Impak Per Minit 冲击数	0 - 4,050
<b>No Load Speed (RPM)</b> Kelajuan Tanpa Beban 回转数	0 - 1,050
<b>Overall Length</b> Panjang Keseluruhan 总长度	352mm (13-7/8")
<b>Net Weight</b> Berat Bersih 净重	2.3kg (5.1lbs)
<b>Power Supply Cord</b> Kabel Wayar 电源线	4.0m (13.1ft)



# IMPACT DRILLING | DEMOLITION

## HR2320T / X2 23mm (7/8") 325 WATT

**Combination Hammer**  
Tukul Kombinasi  
电冲击钻锤



• **3-Mode operation; rotation only, hammering with rotation and hammering only**  
operasi 3 mod: hanya putaran, penukulan dengan putaran, penukulan sahaja  
3档模式变换: 仅旋转, 旋转并锤击, 仅锤击

**Standard Equipment:**  
HR2320T: Side Handle, Depth Gauge, Quick Change Drill Chuck (194079-2)  
HR2320TX2: Side Handle, Depth Gauge, Quick Change Drill Chuck (194079-2), SDS-Plus Drill & Chisel Set (D-46361)

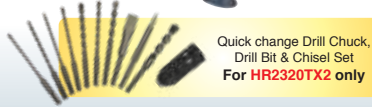

<b>Continuous Rating Input</b> Input Kuasa Berterusan 额定输入功率	720W
<b>Impact Energy</b> Kekuatan Impak 单次最大冲击力	EPTA-Procedure 05/2009: 2.3J Our experimental conditions: 2.6J
<b>Capacity</b> Kapasiti 能力	Concrete: 23mm (7/8") Steel: 13mm (1/2")/ Wood: 32mm (1-1/4") 0 - 4,600
<b>Impacts Per Minute (IPM)</b> Impak Per Minit 冲击数	0 - 1,200
<b>No Load Speed (RPM)</b> Kelajuan Tanpa Beban 回转数	380x77x209mm (15-1/8"x3"x8-1/4")
<b>Dimensions (L x W x H)</b> Dimensi 体积	2.9 - 3.2kg (6.4 - 7.0 lbs)
<b>Net Weight</b> Berat Bersih 净重	2.5m (8.2 ft)
<b>Power Supply Cord</b> Kabel Wayar 电源线	

## HR2470X5 24mm (15/16") 325 WATT

**Combination Hammer**  
Tukul Kombinasi  
电冲击钻锤



• **3-Mode operation; rotation only, hammering with rotation and hammering only**  
operasi 3 mod: hanya putaran, penukulan dengan putaran, penukulan sahaja  
3档模式变换: 仅旋转, 旋转并锤击, 仅锤击

**Standard Equipment:** Side Handle, Depth Gauge, Drill Chuck (194041-7), SDS-Plus Bit Set (D-17784), Bull Point (D-08713)



<b>Continuous Rating Input</b> Input Kuasa Berterusan 额定输入功率	780W
<b>Impact Energy</b> Kekuatan Impak 单次最大冲击力	EPTA-Procedure 05/2009: 2.4J Our experimental conditions: 2.7J
<b>Capacity</b> Kapasiti 能力	Concrete: 24mm (15/16") Core Bit: 54mm (2-1/8") Steel: 13mm (1/2") Wood: 32mm (1-1/4") 0 - 4,500
<b>Impacts Per Minute (IPM)</b> Impak Per Minit 冲击数	0 - 1,100
<b>No Load Speed (RPM)</b> Kelajuan Tanpa Beban 回转数	370x84x214mm (14-1/2"x3-5/16"x8-3/8")
<b>Dimensions (L x W x H)</b> Dimensi 体积	2.9 - 3.3kg (6.4 - 7.3lbs)
<b>Net Weight</b> Berat Bersih 净重	4.0m (13.1ft)
<b>Power Supply Cord</b> Kabel Wayar 电源线	

## HR2631FTX2 26mm (1") 325 WATT

**Combination Hammer**  
Tukul Kombinasi  
电冲击钻锤



• **3-Mode operation; rotation only, hammering with rotation and hammering only**  
operasi 3 mod: hanya putaran, penukulan dengan putaran, penukulan sahaja  
3档模式变换: 仅旋转, 旋转并锤击, 仅锤击

**Standard Equipment:** Side Handle, Depth Gauge, Quick Change Drill Chuck, SDS-Plus Drill & Chisel Set

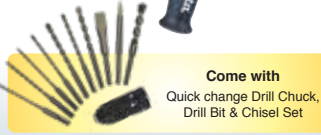

<b>Continuous Rating Input</b> Input Kuasa Berterusan 额定输入功率	800W
<b>Impact Energy</b> Kekuatan Impak 单次最大冲击力	EPTA-Procedure 05/2009: 2.4J Our experimental conditions: 2.9J
<b>Capacity</b> Kapasiti 能力	Concrete: 26mm (1") Core Bit: 68mm (2-11/16") Diamond Core Bit (Dry Type): 80mm (3-1/8") Steel: 13mm (1/2")/ Wood: 32mm (1-1/4") 0 - 4,600
<b>Impacts Per Minute (IPM)</b> Impak Per Minit 冲击数	0 - 1,200
<b>No Load Speed (RPM)</b> Kelajuan Tanpa Beban 回转数	385x77x209mm (15-1/8"x3"x8-1/4")
<b>Dimensions (L x W x H)</b> Dimensi 体积	3.1 - 3.6kg (6.8 - 7.9lbs)
<b>Net Weight</b> Berat Bersih 净重	2.5m (8.2ft)
<b>Power Supply Cord</b> Kabel Wayar 电源线	

## HR2611FT 26mm (1") 325 WATT

**Combination Hammer**  
Tukul Kombinasi  
电冲击钻锤



• **Extremely low vibration achieved by Anti-Vibration Technology**  
Getaran rendah dengan Teknologi anti-getaran AVT  
AVT防震技术降低振动

**Standard Equipment:** Side Grip, Depth Gauge, Quick Change Drill Chuck

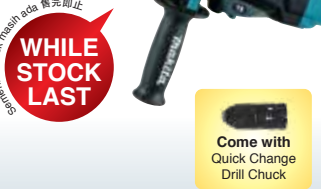

Senantiasa stok penuh ada 售完即止  
**WHILE STOCK LAST**

<b>Continuous Rating Input</b> Input Kuasa Berterusan 额定输入功率	800W
<b>Impact Energy</b> Kekuatan Impak 单次最大冲击力	2.4J
<b>Capacity</b> Kapasiti 能力	Concrete: 26mm (1") Steel: 13mm (1/2")/ Wood: 32mm (1-1/4") 0-4,600
<b>Impacts Per Minute (IPM)</b> Impak Per Minit 冲击数	0-1,200
<b>No Load Speed (RPM)</b> Kelajuan Tanpa Beban 回转数	385x77x209mm (15-1/8"x3"x8-1/4")
<b>Dimensions (L x W x H)</b> Dimensi 体积	3.0kg (6.6lbs)
<b>Net Weight</b> Berat Bersih 净重	2.5m (8.2ft)
<b>Power Supply Cord</b> Kabel Wayar 电源线	

## HR2630X3 26mm (1") 325 WATT

**Combination Hammer**  
Tukul Kombinasi  
电冲击钻锤



• **3-Mode operation; rotation only, hammering with rotation and hammering only**  
operasi 3 mod: hanya putaran, penukulan dengan putaran, penukulan sahaja  
3档模式变换: 仅旋转, 旋转并锤击, 仅锤击

**Standard Equipment:** Side Handle, Depth Gauge, Drill Chuck, SDS-Plus Drill & Chisel Set



<b>Continuous Rating Input</b> Input Kuasa Berterusan 额定输入功率	800W
<b>Impact Energy</b> Kekuatan Impak 单次最大冲击力	EPTA-Procedure 05/2009: 2.4J Our experimental conditions: 2.9J
<b>Capacity</b> Kapasiti 能力	Concrete: 26mm (1") Core Bit: 68mm (2-11/16") Diamond Core Bit (Dry Type): 80mm (3-1/8") Steel: 13mm (1/2") Wood: 32mm (1-1/4") 0 - 4,600
<b>Impacts Per Minute (IPM)</b> Impak Per Minit 冲击数	0 - 1,200
<b>No Load Speed (RPM)</b> Kelajuan Tanpa Beban 回转数	385x77x209mm (15-1/8"x3"x8-1/4")
<b>Dimensions (L x W x H)</b> Dimensi 体积	2.8 - 3.3kg (6.3 - 7.2lbs)
<b>Net Weight</b> Berat Bersih 净重	2.5m (8.2ft)
<b>Power Supply Cord</b> Kabel Wayar 电源线	

Cordless  
Tempa Akut 充电式

LED Flashlight  
Lampu Suluh LED  
LED照明灯

Vacuum Cleaner  
Penyedut Debu  
吸尘器

Drilling / Fastening  
Cepat / Pengikat  
钻孔 / 紧固

Impact Drilling / Demolition  
Ganda / Pemusnah  
冲击钻孔 / 拆除

Cutting  
Pemotong  
切割

Grinding / Sanding  
Pengkilan / Pasukan  
打磨 / 砂磨

Sawing  
Cergas  
锯切

Planing / Routing  
Pegyalan / Tampam  
刨削 / 压边

Others  
Lain-lain  
其他

Outdoor Power Equipment  
Alatan Kuasa Luar  
户外动力工具

Makita  
1915

# IMPACT DRILLING | DEMOLITION

## Large Fan Provides Incredibly High Dust Extraction Power

Kipas besar untuk kuasa ekstraksi habuk yang sangat tinggi  
大风扇提供令人难以置信的高除尘能力



65 mm

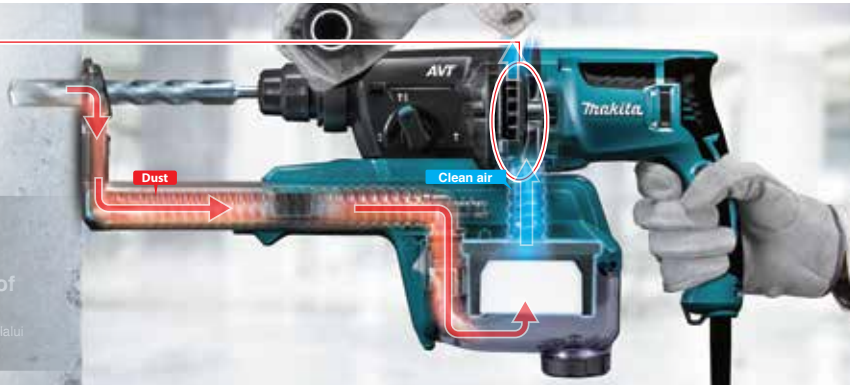

## Equipped with HEPA Filter

Dilengkapi dengan Penapis HEPA 配备 HEPA 过滤器

which removes particles with an efficiency rating of 99.75% from the air passing through

yang menghilangkan zarah dengan penarafan kecekapan 99.75% dari udara yang melalui  
从通过的空气中去除效率等级为99.75%的颗粒

### HR2652 26mm (1")

325 W

#### Combination Hammer with Self Dust Collection

Tukul Kombinasi dengan Sistem Pengumpulan Habuk  
电冲击钻锤与集尘系统

#### • See-through dust case for easy checking of collected dust amount

Tahap pengumpulan habuk mudah dilihat dengan kotak habuk lutsinar  
透视集尘盒方便检查集尘量



Standard Equipment: Side Grip, Depth Gauge, Sealing Cap



<b>Continuous Rating Input</b> Input Kuasa Berterusan 额定输入功率	800W
<b>Impact Energy</b> Kekuatan Impak 单次最大锤击力	EPTA-Procedure 05/2009: 2.2J Our experimental conditions: 2.9J
<b>Capacity</b> Kapasiti 能力	Concrete: 26mm (1") Core Bit: 68mm (2-11/16") Diamond Core Bit: 80mm (3-1/8") Steel: 13mm (1/2") Wood: 32mm (1-1/4")
<b>Impacts Per Minute (IPM)</b> Impak Per Minit 冲击数	0 - 4,600
<b>No Load Speed (RPM)</b> Kelajuan Tanpa Beban 回转数	0 - 1,200
<b>Dimensions (L x W x H)</b> Dimensi 体积	604x89x260mm (23-3/4"x3-1/2"x10-1/4")
<b>Net Weight</b> Berat Bersih 净重	3 - 4.3kg (6.7 - 9.4lbs.)
<b>Power Supply Cord</b> Kabel Wayar 电源线	2.5m (8.2ft.)

### HR2810 28mm (1-1/8")

325 W

#### Combination Hammer

Tukul Kombinasi  
电冲击钻锤

#### • 3-Mode operation; rotation only, hammering with rotation and hammering only

operasi 3 mod: hanya putaran, penukulan dengan putaran, penukulan sahaja  
3档模式变换: 仅旋转, 旋转并锤击, 仅锤击



Standard Equipment: Depth Gauge, Side Grip



<b>Continuous Rating Input</b> Input Kuasa Berterusan 额定输入功率	800W
<b>Impact Energy</b> Kekuatan Impak 单次最大锤击力	EPTA-Procedure 05/2009: 2.8J Our experimental conditions: 2.9J
<b>Capacity</b> Kapasiti 能力	Concrete (T.C.T. bit): 28mm (1-1/8") Steel: 13mm (1/2") Wood: 32mm (1-1/4")
<b>Impacts Per Minute (IPM)</b> Impak Per Minit 冲击数	0 - 4,500
<b>No Load Speed (RPM)</b> Kelajuan Tanpa Beban 回转数	0 - 1,100
<b>Dimensions (L x W x H)</b> Dimensi 体积	314x89x225mm (12-3/8"x3-1/2"x8-7/8")
<b>Net Weight</b> Berat Bersih 净重	3.4 - 3.8kg (7.5 - 8.5lbs)
<b>Power Supply Cord</b> Kabel Wayar 电源线	2.5m (8.2ft.)

### HR3210C 32mm (1-1/4")

350 W

#### Combination Hammer

Tukul Kombinasi  
电冲击钻锤

#### • 3-Mode operation; rotation only, hammering with rotation and hammering only

operasi 3 mod: hanya putaran, penukulan dengan putaran, penukulan sahaja  
3档模式变换: 仅旋转, 旋转并锤击, 仅锤击



Standard Equipment: Depth Gauge, Side Grip, Grease vessel

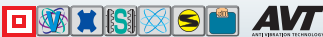

<b>Continuous Rating Input</b> Input Kuasa Berterusan 额定输入功率	850W
<b>Impact Energy</b> Kekuatan Impak 单次最大锤击力	EPTA-Procedure 05/2009: 5J Our experimental conditions: 5.5J
<b>Capacity</b> Kapasiti 能力	Concrete (T.C.T. bit): 32mm (1-1/4") Steel: 13mm (1/2") Wood: 32mm (1-1/4") Concrete (Core bit): 90mm (3-1/2")
<b>Impacts Per Minute (IPM)</b> Impak Per Minit 冲击数	1,650 - 3,300
<b>No Load Speed (RPM)</b> Kelajuan Tanpa Beban 回转数	315 - 630
<b>Dimensions (L x W x H)</b> Dimensi 体积	398x114x239mm (15-5/8"x4-1/2"x9-3/8")
<b>Net Weight</b> Berat Bersih 净重	5.2 - 5.6kg (11.4 - 12.4lbs)
<b>Power Supply Cord</b> Kabel Wayar 电源线	5.0m (16.4ft)

### HR3200C 32mm (1-1/4")

350 W

#### Combination Hammer

Tukul Kombinasi  
冲击电钻电锤

#### • 3-Mode operation; rotation only, hammering with rotation and hammering only

operasi 3 mod: hanya putaran, penukulan dengan putaran, penukulan sahaja  
3档模式变换: 仅旋转, 旋转并锤击, 仅锤击



Standard Equipment: Depth Gauge, Side Grip, Grease Vessel (181573-3)



<b>Continuous Rating Input</b> Input Kuasa Berterusan 额定输入功率	850W
<b>Impact Energy</b> Kekuatan Impak 单次最大锤击力	EPTA-Procedure 05/2009: 5.1J Our experimental conditions: 5.5J
<b>Capacity</b> Kapasiti 能力	Concrete (T.C.T. bit): 32mm (1-1/4") Steel: 13mm (1/2") Wood: 32mm (1-1/4")
<b>Impacts Per Minute (IPM)</b> Impak Per Minit 冲击数	1,650 - 3,300
<b>No Load Speed (RPM)</b> Kelajuan Tanpa Beban 回转数	315 - 630
<b>Dimensions (L x W x H)</b> Dimensi 体积	398x108x239mm (15-5/8"x4-1/4"x9-3/8")
<b>Net Weight</b> Berat Bersih 净重	4.8 - 5.2kg (10.5 - 11.5lbs)
<b>Power Supply Cord</b> Kabel Wayar 电源线	5.0m (16.4ft)

Cordless  
Tahap Kuasa Berterusan

LED Flashlight  
Lampu Suhu LED  
LED 照明灯

Vacuum Cleaner  
Penapis Vakuum  
吸尘器

Drilling | Fastening  
Operasi Pengikat  
钻孔 | 紧固

Impact Drilling | Demolition  
Operasi Penaklukan  
冲击钻孔 | 拆卸加工

Cutting  
Pemotongan  
切割

Grinding | Sanding  
Pengamiran | Pemoiran  
打磨 | 磨光

Sawing  
Gergaji  
锯切

Planing | Routing  
Pengamiran | Tumpang  
刨削 | 雕刻

Others  
Lain-lain  
其他

Outdoor Power Equipment  
Alat-alat Kuasa Luar  
户外动力设备

Makita  
MAKITA

# IMPACT DRILLING | DEMOLITION

## HR3530 35mm (1-3/8") 350 W

**Rotary Hammer**  
Tukul Putar  
电锤



- **Compact and lightweight design**  
Kompak dan ringan  
小巧轻便

Standard Equipment: Side Grip, Depth Gauge



<b>Continuous Rating Input</b> Input Kuasa Berterusan 额定输入功率	1,010W
<b>Impact Energy</b> Kekuatan Impak 单次最大冲击力	Our experimental conditions: 6.2J
<b>Capacity</b> Kapasiti 能力	Concrete (T.C.T. bit) : 35mm (1-3/8") Concrete (Core bit) : 105mm (4-1/8")
<b>Impacts Per Minute (IPM)</b> Impak Per Minit 冲击数	3,100
<b>No Load Speed (RPM)</b> Kelajuan Tanpa Beban 回转数	760
<b>Dimensions (L x W x H)</b> Dimensi 体积	374x100x243mm (14-3/4"x3-15/16"x9-9/16")
<b>Net Weight</b> Berat Bersih 净重	5.8kg (12.8lbs)
<b>Power Supply Cord</b> Kabel Wayar 电源线	5.0m (16.4ft)

## HR4001C 40mm (1-9/16") 350 W

**Rotary Hammer**  
Tukul Putar  
电锤



- **2-Mode operation for Rotation with Hammering or Hammering only**  
Operasi 2-Mod untuk penukulan dengan putaran, penukulan sahaja  
仅锤击或旋转锤击的双模式操作

Standard Equipment: Depth Gauge, Side Grip, Grease vessel



<b>Continuous Rating Input</b> Input Kuasa Berterusan 额定输入功率	1,100W
<b>Impact Energy</b> Kekuatan Impak 单次最大冲击力	EPTA-Procedure 05/2009: 6.8J Our experimental conditions: 9.5J
<b>Capacity</b> Kapasiti 能力	Concrete (T.C.T. bit): 40mm (1-9/16") Concrete (Core bit): 105mm (4-1/8")
<b>Impacts Per Minute (IPM)</b> Impak Per Minit 冲击数	1,350-2,750
<b>No Load Speed (RPM)</b> Kelajuan Tanpa Beban 回转数	235-480
<b>Dimensions (L x W x H)</b> Dimensi 体积	468x106x261mm (18-1/2"x4-3/16"x10-1/4")
<b>Net Weight</b> Berat Bersih 净重	5.9kg (13.0lbs)
<b>Power Supply Cord</b> Kabel Wayar 电源线	5.0m (16.4ft)

## HR4002 40mm (1-9/16") 350 W

**Rotary Hammer**  
Tukul Putar  
电锤



- **2-Mode operation for Rotation with Hammering or Hammering only**  
Operasi 2-Mod untuk penukulan dengan putaran, penukulan sahaja  
仅锤击或旋转锤击的双模式操作

Standard Equipment: Side Grip, Bit Grease, Depth Gauge



<b>Continuous Rating Input</b> Input Kuasa Berterusan 额定输入功率	1,050W
<b>Impact Energy</b> Kekuatan Impak 单次最大冲击力	EPTA-Procedure 05/2009: 6.1J Our experimental conditions: 6.2J
<b>Capacity</b> Kapasiti 能力	Concrete (T.C.T. bit) : 40mm (1-9/16") Concrete (Core bit) : 105mm (4-1/8")
<b>Impacts Per Minute (IPM)</b> Impak Per Minit 冲击数	2,500
<b>No Load Speed (RPM)</b> Kelajuan Tanpa Beban 回转数	680
<b>Dimensions (L x W x H)</b> Dimensi 体积	458x114x256mm (18"x4-1/2"x10-1/8")
<b>Net Weight</b> Berat Bersih 净重	6.6 - 6.8kg (14.6 - 15.0lbs)
<b>Power Supply Cord</b> Kabel Wayar 电源线	5.0m (16.4ft)

## HR4003C 40mm (1-9/16") 350 W

**Rotary Hammer**  
Tukul Putar  
电锤



- **2-Mode operation for Rotation with Hammering or Hammering only**  
Operasi 2-Mod untuk penukulan dengan putaran, penukulan sahaja  
仅锤击或旋转锤击的双模式操作

Standard Equipment: Depth Gauge, Side Handle, Bit Grease, Cloth



<b>Continuous Rating Input</b> Input Kuasa Berterusan 额定输入功率	1,100W
<b>Impact Energy</b> Kekuatan Impak 单次最大冲击力	EPTA-Procedure 05/2009: 8.3J Our experimental conditions: 11.4J
<b>Capacity</b> Kapasiti 能力	Concrete (T.C.T. bit) : 40mm (1-9/16") Concrete (Core bit) : 105mm (4-1/8")
<b>Impacts Per Minute (IPM)</b> Impak Per Minit 冲击数	1,450 - 2,900
<b>No Load Speed (RPM)</b> Kelajuan Tanpa Beban 回转数	250 - 500
<b>Dimensions (L x W x H)</b> Dimensi 体积	479x106x263mm (18-11/16"x4-3/16"x10-3/8")
<b>Net Weight</b> Berat Bersih 净重	6.2 - 6.4kg (13.7 - 14.1lbs)
<b>Power Supply Cord</b> Kabel Wayar 电源线	5.0m (16.4ft)

## HR4013C 40mm (1-9/16") 350 W

**Rotary Hammer**  
Tukul Putar  
电锤



- **2-Mode operation for Rotation with Hammering or Hammering only**  
Operasi 2-Mod untuk penukulan dengan putaran, penukulan sahaja  
仅锤击或旋转锤击的双模式操作

Standard Equipment: Depth Gauge, Side Handle (D), Side Grip, Bit Grease, Cloth



<b>Continuous Rating Input</b> Input Kuasa Berterusan 额定输入功率	1,100W
<b>Impact Energy</b> Kekuatan Impak 单次最大冲击力	EPTA-Procedure 05/2009: 8J Our experimental conditions: 11.4J
<b>Capacity</b> Kapasiti 能力	Concrete (T.C.T. bit) : 40mm (1-9/16") Concrete (Core bit) : 105mm (4-1/8")
<b>Impacts Per Minute (IPM)</b> Impak Per Minit 冲击数	1,450 - 2,900
<b>No Load Speed (RPM)</b> Kelajuan Tanpa Beban 回转数	250 - 500
<b>Dimensions (L x W x H)</b> Dimensi 体积	479x112x263mm (18-11/16"x4-3/8"x10-3/8")
<b>Net Weight</b> Berat Bersih 净重	6.8 - 6.9kg (14.9 - 15.3lbs)
<b>Power Supply Cord</b> Kabel Wayar 电源线	5.0m (16.4ft)



Cordless  
Tenggakord 无线式

LED Flashlight  
Lampu Suhu LED  
LED照灯

Vacuum Cleaner  
Pembersih Vakuam  
吸尘器

Drilling | Fastening  
Gergaji | Pasang  
钻孔 | 紧固

Impact Drilling | Demolition  
Gergaji | Pasang  
冲击钻孔 | 拆除施工

Cutting  
Pemotong  
切割

Grinding | Sanding  
Penghalus | Pasah  
打磨 | 打磨

Sawing  
Gergaji  
锯切

Planing | Routing  
Penghalus | Tumpang  
刨平 | 刨平

Others  
Lain-lain  
其他

Outdoor Power Equipment  
Alatan Kerja Luar  
户外动力设备



# IMPACT DRILLING | DEMOLITION

Cordless  
Tangkal Kord Listrik

LED Flashlight  
Lampu Suhu LED  
LECO/LED

Vacuum Cleaner  
Pembersih Vakum  
真流式

Drilling | Fastening  
Drill / Pengikat  
钻头 / 螺丝

Impact Drilling | Demolition  
Drill / Pemecah  
石工钻头 / 墙壁加工

Cutting  
Pemotong  
切割机

Grinding | Sanding  
Pengam / Poles  
研磨 / 打磨

Sawing  
Gergaji  
锯切

Planing | Routing  
Pengam / Tergam  
刨削 / 雕刻



Others  
Lain-lain  
其他

Outdoor Power Equipment  
Alat-alat Tenaga Luar  
园林/户外

Makita  
真流式

**HR4030C** 40mm (1-9/16") 350

**Rotary Hammer**  
Tukul Putar  
电锤

**2 modes**

- **2-Mode operation for Rotation with Hammering or Hammering only**  
Operasi 2-Mod untuk penukulan dengan putaran, penukulan sahaja  
仅锤击或旋转锤击的双模式操作

**Standard Equipment:** Depth Gauge, Side Grip



<b>Continuous Rating Input</b> Input Kuasa Berterusan 额定输入功率	1,100W
<b>Impact Energy</b> Kekuatan Impak 单次最大锤击力	Our experimental conditions: 9.2J
<b>Capacity</b> Kapasiti 能力	Concrete (T.C.T. bit) : 40mm (1-9/16")/ Concrete (Core bit) : 118mm (4-5/8")
<b>Impacts Per Minute (IPM)</b> Impak Per Minit 冲击数	1,300 - 2,600
<b>No Load Speed (RPM)</b> Kelajuan Tanpa Beban 回转数	230 - 460
<b>Dimensions (L x W x H)</b> Dimensi 体积	413x107x247mm (16-1/4"x4-1/4"x9-3/4")
<b>Net Weight</b> Berat Bersih 净重	6.9kg (15.2lbs)
<b>Power Supply Cord</b> Kabel Wayar 电源线	5.0m (16.4ft)

**HR4501C** 45mm (1-3/4") 175

**Rotary Hammer**  
Tukul Putar  
电锤



**2 modes**

- **High performance and durability**  
Prestasi dan ketahanan tinggi  
高性能兼耐用



**Standard Equipment:** Side Handle (D), Side Grip, Depth Gauge, Grease Vessel, Cloth



<b>Continuous Rating Input</b> Input Kuasa Berterusan 额定输入功率	1,350W
<b>Impact Energy</b> Kekuatan Impak 单次最大锤击力	EPTA-Procedure 05/2009: 10.1J Our experimental conditions: 12.5J
<b>Capacity</b> Kapasiti 能力	Concrete (T.C.T. bit) : 45mm (1-3/4")/ Concrete (Core bit) : 125mm (5")
<b>Impacts Per Minute (IPM)</b> Impak Per Minit 冲击数	1,250 - 2,750
<b>No Load Speed (RPM)</b> Kelajuan Tanpa Beban 回转数	130 - 280
<b>Dimensions (L x W x H)</b> Dimensi 体积	458x121x288mm (18"x4-3/4"x11-3/8")
<b>Net Weight</b> Berat Bersih 净重	8.2 - 8.4kg (18.1 - 18.5lbs)
<b>Power Supply Cord</b> Kabel Wayar 电源线	5.0m (16.4ft)

**HR4511C** 45mm (1-3/4") 175

**Rotary Hammer**  
Tukul Putar  
电锤

**2 modes**

- **2-Mode operation for Rotation with Hammering or Hammering only**  
Operasi 2-Mod untuk penukulan dengan putaran, penukulan sahaja  
仅锤击或旋转锤击的双模式操作



**Standard Equipment:** Side handle (D), Side Grip, Depth Gauge, Grease Vessel, Cloth



<b>Continuous Rating Input</b> Input Kuasa Berterusan 额定输入功率	1,350W
<b>Impact Energy</b> Kekuatan Impak 单次最大锤击力	EPTA-Procedure 05/2009: 9.4J Our experimental conditions: 12.5J
<b>Capacity</b> Kapasiti 能力	Concrete (T.C.T. bit) : 45mm (1-3/4")/ Concrete (Core bit) : 125mm (5")
<b>Impacts Per Minute (IPM)</b> Impak Per Minit 冲击数	1,250 - 2,750
<b>No Load Speed (RPM)</b> Kelajuan Tanpa Beban 回转数	130 - 280
<b>Dimensions (L x W x H)</b> Dimensi 体积	458x136x288mm (18"x5-3/8"x11-3/8")
<b>Net Weight</b> Berat Bersih 净重	9.0 - 9.1kg (19.8 - 20.1lbs)
<b>Power Supply Cord</b> Kabel Wayar 电源线	5.0m (16.4ft)

**HR5202C** 52mm (2-1/16") 175

**Rotary Hammer**  
Tukul Putar  
电锤

**2 modes**

- **2-Mode operation for Rotation with Hammering or Hammering only**  
Operasi 2-Mod untuk penukulan dengan putaran, penukulan sahaja  
仅锤击或旋转锤击的双模式操作



**Standard Equipment:** Side handle (D), Side Grip, Depth Gauge, Grease Vessel, Cloth



<b>Continuous Rating Input</b> Input Kuasa Berterusan 额定输入功率	1,510W
<b>Impact Energy</b> Kekuatan Impak 单次最大锤击力	EPTA-Procedure 05/2009: 19.1J Our experimental conditions: 21J
<b>Capacity</b> Kapasiti 能力	Concrete (T.C.T. bit) : 52mm (2")/ Concrete (Core bit) : 160mm (6-5/16")
<b>Impacts Per Minute (IPM)</b> Impak Per Minit 冲击数	1,100 - 2,250
<b>No Load Speed (RPM)</b> Kelajuan Tanpa Beban 回转数	150 - 310
<b>Dimensions (L x W x H)</b> Dimensi 体积	599x134x287mm (23-1/2"x5-1/4"x11-1/4")
<b>Net Weight</b> Berat Bersih 净重	10.9 - 11.1kg (24.1 - 24.4lbs)
<b>Power Supply Cord</b> Kabel Wayar 电源线	5.0m (16.4ft)

**HR5211C** 52mm (2-1/16") 175

**Rotary Hammer**  
Tukul Putar  
电锤

**2 modes**

- **2-Mode operation for Rotation with Hammering or Hammering only**  
Operasi 2-Mod untuk penukulan dengan putaran, penukulan sahaja  
仅锤击或旋转锤击的双模式操作

**Standard Equipment:** Side handle (D), Side Grip, Depth Gauge, Grease Vessel



<b>Continuous Rating Input</b> Input Kuasa Berterusan 额定输入功率	1,500W
<b>Impact Energy</b> Kekuatan Impak 单次最大锤击力	EPTA-Procedure 05/2009: 18.9J Our experimental conditions: 20J
<b>Capacity</b> Kapasiti 能力	Concrete (T.C.T. bit) : 52mm (2")/ Concrete (Core bit) : 160mm (6-1/4")
<b>Impacts Per Minute (IPM)</b> Impak Per Minit 冲击数	1,075 - 2,150
<b>No Load Speed (RPM)</b> Kelajuan Tanpa Beban 回转数	130 - 260
<b>Dimensions (L x W x H)</b> Dimensi 体积	599x149x287mm (23-1/2"x5-7/8"x11-1/4")
<b>Net Weight</b> Berat Bersih 净重	12.2kg (26.8lbs)
<b>Power Supply Cord</b> Kabel Wayar 电源线	5.0m (16.4ft)

# IMPACT DRILLING | DEMOLITION

## HR5212C 52mm (2-1/16")

175

### Rotary Hammer Tukul Putar 电锤



- 2-Mode operation for Rotation with Hammering or Hammering only  
Operasi 2-Mod untuk penukulan dengan putaran, penukulan sahaja  
仅锤击或旋转锤击的双模式操作



Standard Equipment: Side Handle, Side Grip, Depth Gauge, Grease Vessel, Cloth



<b>Continuous Rating Input</b> Input Kuasa Berterusan 额定输入功率	1,510W
<b>Impact Energy</b> Kekuatan Impak 单次最大冲击力	EPTA-Procedure 05/2009: 20J Our experimental conditions: 21J
<b>Capacity</b> Kapasiti 能力	Concrete (T.C.T. bit) : 52mm (2") Concrete (Core bit) : 160mm (6-5/16")
<b>Impacts Per Minute (IPM)</b> Impak Per Minit 冲击数	1,100 - 2,250
<b>No Load Speed (RPM)</b> Kelajuan Tanpa Beban 回转数	150 - 310
<b>Dimensions (L x W x H)</b> Dimensi 体积	599x140x287mm (23-1/2"x5-1/2"x11-1/4")
<b>Net Weight</b> Berat Bersih 净重	11.9 - 12.0kg (26.2 - 26.5lbs)
<b>Power Supply Cord</b> Kabel Wayar 电源线	5.0m (16.4ft)

## HM0810TA 17mm (11/16") Hex Shank

105

### Demolition Hammer Pemahat Tukul Elektrik 电动槌



- Ideal for light chiseling, chipping and scaling operations  
Sesuai untuk operasi ringan untuk pahatan, penyerpihan dan perkalaan  
适用于轻凿击、碎击和铲除原有表面等操作



Standard Equipment: Bull Point, Hex Wrench, Side Grip



<b>Continuous Rating Input</b> Input Kuasa Berterusan 额定输入功率	900W
<b>Impact Energy</b> Kekuatan Impak 单次最大冲击力	EPTA-Procedure 05/2009: 7.2J Our experimental conditions: 7.6J
<b>Impacts Per Minute (IPM)</b> Impak Per Minit 冲击数	2,900
<b>Overall Length</b> Panjang Keseluruhan 总长度	428mm (16-7/8")
<b>Net Weight</b> Berat Bersih 净重	6.3kg (13.9lbs)
<b>Power Supply Cord</b> Kabel Wayar 电源线	5.0m (16.4ft)

## HM0870C

350

### Demolition Hammer Pemahat Tukul Elektrik 电动槌



- Compact Power with Less Weight  
Kompak dan ringan  
紧凑更重



Standard Equipment: Grease for bit, Side Handle, Cloth



<b>Continuous Rating Input</b> Input Kuasa Berterusan 额定输入功率	1,100W
<b>Impact Energy</b> Kekuatan Impak 单次最大冲击力	EPTA-Procedure 05/2009: 7.6J Our experimental conditions: 11.4J
<b>Impacts Per Minute (IPM)</b> Impak Per Minit 冲击数	1,100 - 2,650
<b>Dimensions (L x W x H)</b> Dimensi 体积	449x109x230mm (17-3/4"x4-1/4"x9")
<b>Net Weight</b> Berat Bersih 净重	5.1 - 5.3kg (11.1 - 11.6lbs)
<b>Power Supply Cord</b> Kabel Wayar 电源线	5.0m (16.4ft)

## HM0871C

350

### Demolition Hammer Pemahat Tukul Elektrik 电动槌



- High durability and excellent demolition performance  
Ketahanan dan prestasi yang tinggi  
高耐用性



Standard Equipment: Grease for bit, Side Handle, Cloth



<b>Continuous Rating Input</b> Input Kuasa Berterusan 额定输入功率	1,100W
<b>Impact Energy</b> Kekuatan Impak 单次最大冲击力	EPTA-Procedure 05/2009: 8.1J Our experimental conditions: 11.6J
<b>Impacts Per Minute (IPM)</b> Impak Per Minit 冲击数	1,100 - 2,650
<b>Dimensions (L x W x H)</b> Dimensi 体积	466x116x230mm (18-3/8"x4-9/16"x9")
<b>Net Weight</b> Berat Bersih 净重	5.6 - 5.8kg (12.4 - 12.8lbs)
<b>Power Supply Cord</b> Kabel Wayar 电源线	5.0m (16.4ft)



Cordless  
Tenggakord 无线式

LED Flashlight  
Lampu Suluh LED  
LED照明灯

Vacuum Cleaner  
Pembersih Vakuam  
吸尘器

Drilling | Fastening  
Cepat | Pengikat  
钻孔 | 紧固

Impact Drilling | Demolition  
Cepat | Pemusnah  
冲击钻孔 | 拆除施工

Cutting  
Pemotong  
切割

Grinding | Sanding  
Pengkilan | Pasukan  
打磨 | 砂磨

Sawing  
Cepat  
锯切

Planing | Routing  
Pengkilan | Tanggapan  
刨削 | 雕刻

Others  
Lain-lain  
其他

Outdoor Power Equipment  
Alatan Kerja Luar  
户外动力工具

Makita  
1915

# IMPACT DRILLING | DEMOLITION

## HM1201 21mm (13/16") Hex Shank

155

**Demolition Hammer**  
Pemahat Tukul Elektrik  
电动槌



- **Powerful impact from durable aluminum body**  
Tahan lama dan berkuasa  
耐用铝合金机身提供强大的冲击力

Standard Equipment: Bull Point, Hex Wrench, Side Grip



<b>Continuous Rating Input</b> Input Kuasa Berterusan 额定输入功率	1,130W
<b>Impact Energy</b> Kekuatan Impak 单次最大锤击力	Our experimental conditions: 13J
<b>Impacts Per Minute (IPM)</b> Impak Per Minit 冲击数	2,000
<b>Overall Length</b> Panjang Keseluruhan 总长度	480mm (18-7/8")
<b>Net Weight</b> Berat Bersih 净重	9.1kg (20.1lbs)
<b>Power Supply Cord</b> Kabel Wayar 电源线	5.0m (16.4ft)

## HM1213C

175

**Demolition Hammer**  
Pemahat Tukul Elektrik  
电动槌



- **Vibration absorbing handle provides comfortable operation**  
Pemegang menyerap getaran untuk operasi yang selesa  
吸振手柄提供舒适的操作

Standard Equipment: Bull Point, Bit Grease, Side Handle, Cloth



<b>Continuous Rating Input</b> Input Kuasa Berterusan 额定输入功率	1,510W
<b>Impact Energy</b> Kekuatan Impak 单次最大锤击力	EPTA-Procedure 05/2009: 18.6J Our experimental conditions: 25.5J
<b>Impacts Per Minute (IPM)</b> Impak Per Minit 冲击数	950 - 1,900
<b>Dimensions (L x W x H)</b> Dimensi 体积	576x149x265mm (22-3/4"x5-7/8"x10-3/8")
<b>Net Weight</b> Berat Bersih 净重	10.8kg (23.7lbs)
<b>Power Supply Cord</b> Kabel Wayar 电源线	5.0m (16.4ft)

## HM1203C

175

**Demolition Hammer**  
Pemahat Tukul Elektrik  
电动槌



- **Increasing energy transfer for more power**  
Meningkatkan pemindahan tenaga untuk lebih banyak kuasa  
增加能量传递以获得更多电力

Standard Equipment: Bull Point, Bit Grease, Side Handle



<b>Continuous Rating Input</b> Input Kuasa Berterusan 额定输入功率	1,510W
<b>Impact Energy</b> Kekuatan Impak 单次最大锤击力	EPTA-Procedure 05/2009: 19.1J Our experimental conditions: 25.5J
<b>Impacts Per Minute (IPM)</b> Impak Per Minit 冲击数	950 - 1,900
<b>Dimensions (L x W x H)</b> Dimensi 体积	576x128x265mm (22-3/4"x5-1/8"x10-3/8")
<b>Net Weight</b> Berat Bersih 净重	9.7kg (21.5lbs)
<b>Power Supply Cord</b> Kabel Wayar 电源线	5.0m (16.4ft)

## HM1214C

175

**Demolition Hammer**  
Pemahat Tukul Elektrik  
电动槌



- **Powerful 1,510W motor**  
Motor berkuasa 1,510W  
强大马达1.510W

Standard Equipment: Bull Point, Bit Grease, Side Handle, Cloth



<b>Continuous Rating Input</b> Input Kuasa Berterusan 额定输入功率	1,510W
<b>Impact Energy</b> Kekuatan Impak 单次最大锤击力	EPTA-Procedure 05/2009: 19.9J Our experimental conditions: 26J
<b>Impacts Per Minute (IPM)</b> Impak Per Minit 冲击数	950 - 1,900
<b>Dimensions (L x W x H)</b> Dimensi 体积	700x129x265mm (27-1/2"x5-1/8"x10-3/8")
<b>Net Weight</b> Berat Bersih 净重	12.3kg (27.1lbs)
<b>Power Supply Cord</b> Kabel Wayar 电源线	5.0m (16.4ft)

## HM1306 30mm (1-3/16") Hex Shank

204

**Demolition Hammer**  
Pemahat Tukul Elektrik  
电动槌



- **Powerful 1,510W motor**  
Motor berkuasa 1,510W  
强大马达1.510W

Standard Equipment: Bull Point, Wrench, Side Handle, Oil Supply 100ml



<b>Continuous Rating Input</b> Input Kuasa Berterusan 额定输入功率	1,510W
<b>Impact Energy</b> Kekuatan Impak 单次最大锤击力	EPTA-Procedure 05/2009: 21.7J Our experimental conditions: 28.8J
<b>Impacts Per Minute (IPM)</b> Impak Per Minit 冲击数	1,450
<b>Dimensions (L x W x H)</b> Dimensi 体积	652x121x231mm (25-3/4"x4-3/4"x9-1/8")
<b>Net Weight</b> Berat Bersih 净重	15.1kg (33.3lbs)
<b>Power Supply Cord</b> Kabel Wayar 电源线	5.0m (16.4ft)

Cordless  
Tahan Kord 无绳式

LED Flashlight  
Lampu Suhu LED  
LED 照明灯

Vacuum Cleaner  
Pembersih Vakuum  
吸尘器

Drilling | Fastening  
Gasing | Pengikat  
钻孔 | 紧固

Impact Drilling | Demolition  
Gasing | Pembersih  
冲击钻孔 | 拆除施工

Cutting  
Pemotong  
切割

Grinding | Sanding  
Hengap | Habis  
打磨 | 磨光

Sawing  
Gasing  
锯切

Planing | Routing  
Pengaliran | Tinggah  
刨削 | 雕刻

Others  
Lain-lain  
其他

Outdoor Power Equipment  
Alatan Kuasa Luar  
户外动力设备

Makita  
Makita

# IMPACT DRILLING | DEMOLITION

## HM1317C 30mm (1-3/16") Hex Shank

175

### Electric Breaker

Tukul Elektrik  
电动链



- High durability and excellent demolition performance  
Ketahanan dan berprestasi tinggi  
高耐用性



Standard Equipment: Side Handle



<b>Continuous Rating Input</b> Input Kuasa Berterusan 额定输入功率	1,510W
<b>Impact Energy</b> Kekuatan Impak 单次最大冲击力	EPTA-Procedure 05/2009: 25 (100-127 V: 21) J Our experimental conditions: 33.8 J
<b>Impacts Per Minute (IPM)</b> Impak Per Minit 冲击数	730 - 1,450
<b>Dimensions (L x W x H)</b> Dimensi 体积	715x129x266mm (28-1/8"x5-1/8"x10-1/2")
<b>Net Weight</b> Berat Bersih 净重	17kg (37.5lbs)
<b>Power Supply Cord</b> Kabel Wayar 电源线	5.0m (16.4ft)

## HM1307C 30mm (1-3/16") Hex Shank

175

### Electric Breaker

Tukul Elektrik  
电动链



- Electronic Controller for Operator Convenience  
Kawalan Elektronik memudahkan pengguna  
电子控制方便使用



Standard Equipment: Side Handle, Bull Point



<b>Continuous Rating Input</b> Input Kuasa Berterusan 额定输入功率	1,510W
<b>Impact Energy</b> Kekuatan Impak 单次最大冲击力	EPTA-Procedure 05/2009: 25.5J Our experimental conditions: 33.8J
<b>Impacts Per Minute (IPM)</b> Impak Per Minit 冲击数	730 - 1,450
<b>Dimensions (L x W x H)</b> Dimensi 体积	715x129x266mm (28-1/8"x5-1/8"x10-1/2")
<b>Net Weight</b> Berat Bersih 净重	15.3kg (33.8lbs)
<b>Power Supply Cord</b> Kabel Wayar 电源线	5.0m (16.4ft)

## HM1810 28.6mm (1-1/8") Hex Shank

204

### Electric Breaker

Tukul Elektrik  
电动链



- Powerful 2,000W motor  
Motor berkuasa 2,000W  
强大马达2,000W



Standard Equipment: Hex Wrench



<b>Continuous Rating Input</b> Input Kuasa Berterusan 额定输入功率	2,000W
<b>Impact Energy</b> Kekuatan Impak 单次最大冲击力	EPTA-Procedure 05/2009: 44.9J Our experimental conditions: 63J
<b>Impacts Per Minute (IPM)</b> Impak Per Minit 冲击数	1,100
<b>Dimensions (L x W x H)</b> Dimensi 体积	824x146x633mm (32-1/2"x5-3/4"x25")
<b>Net Weight</b> Berat Bersih 净重	32.0kg (70.6lbs)
<b>Power Supply Cord</b> Kabel Wayar 电源线	5.0m (16.4ft)

## HM1812 28.6mm (1-1/8") Hex Shank

218

### Electric Breaker

Tukul Elektrik  
电动链



- Hits like air without the vibration  
Tukulan mudah  
轻易撞击



Standard Equipment: Bull Point, Hex Wrench



<b>Continuous Rating Input</b> Input Kuasa Berterusan 额定输入功率	2,000W
<b>Impact Energy</b> Kekuatan Impak 单次最大冲击力	EPTA-Procedure 05/2009: 72.8J Our experimental conditions: 62J
<b>Impacts Per Minute (IPM)</b> Impak Per Minit 冲击数	870
<b>Dimensions (L x W x H)</b> Dimensi 体积	843x210x608mm (33-1/4"x8-1/4"x24")
<b>Net Weight</b> Berat Bersih 净重	31.3kg (69lbs)
<b>Power Supply Cord</b> Kabel Wayar 电源线	5.0m (16.4ft)

## HK1820

350

### Power Scraper

Pengikis Elektrik  
电动刮剥机



- Large trigger switch with variable speed control function  
Suis pencetus yang besar dengan fungsi kawalan kelajuan  
备用变速控制功能的大型触发开关



Standard Equipment: Bull Point, Scaling Chisel, Scaling chisel (for tile), Hook complete

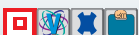

<b>Continuous Rating Input</b> Input Kuasa Berterusan 额定输入功率	550W
<b>Impact Energy</b> Kekuatan Impak 单次最大冲击力	EPTA-Procedure 05/2009: 3.1J Our experimental conditions: 3.9J
<b>Impacts Per Minute (IPM)</b> Impak Per Minit 冲击数	0 - 3,200
<b>Dimensions (L x W x H)</b> Dimensi 体积	351x102x203mm (13-3/4"x4"x8")
<b>Net Weight</b> Berat Bersih 净重	3.4kg (7.5lbs)
<b>Power Supply Cord</b> Kabel Wayar 电源线	5.0m (16.4ft)

Cordless  
Tenggakord 无线式

LED Flashlight  
Lampu Suhu LED  
LED照明灯

Vacuum Cleaner  
Pembersih Vakuam  
吸尘器

Drilling | Fastening  
Cairul | Pengikat  
钻孔 | 紧固

Impact Drilling | Demolition  
Cairul | Penebuk  
冲击钻孔 | 拆除施工

Cutting  
Pemotong  
切割

Grinding | Sanding  
Pengkilan | Palsan  
打磨 | 砂磨

Sawing  
Cergah  
锯切

Planing | Routing  
Pegyalan | Tanggam  
刨削 | 压嵌

Others  
Lain-lain  
其他

Outdoor Power Equipment  
Alatan Keraf Luar  
户外动力工具

Makita  
MAKITA





				EPTA Weight (kg)	0 10 20 30 40 50 60 70 80 90 100 110 120 130 140 150 160																	MATERIAL FOR DRILLING			
																						Highly reinforced concrete	Concrete, granite, stone, brick	Metal/wood	Working direction
26mm series	DHR263		4.1 - 5.1	3.2-26 4-18																	✓	✓✓✓	✓	↕	
	SDS-plus			35-54																					Diamond core 32 ~ 65 (dry type)
26mm series	HR2651		3.0 - 3.2	3.2-26 4-18																	✓	✓✓✓	✓	↕	
	SDS-plus			35-68																					Diamond core 32 ~ 80 (dry type)
26mm series	HR2650		3.0 - 3.2	3.2-26 4-18																	✓	✓✓✓	✓	↕	
	SDS-plus			35-68																					Diamond core 32 ~ 80 (dry type)
26mm series	HR2631FT		2.8 - 3.5	3.2-26 4-18																	✓	✓✓✓	✓	↕	
	SDS-plus			35-68																					Diamond core 32 ~ 80 (dry type)
26mm series	HR2630		2.8 - 3.5	3.2-26 4-18																	✓	✓✓✓	✓	↕	
	SDS-plus			35-68																					Diamond core 32 ~ 80 (dry type)
26mm series	HR2611FT		2.8 - 3.0	3.2-26 4-18																	✓	✓✓✓	✓	↕	
	SDS-plus			35-68																					Diamond core 32 ~ 80 (dry type)

				EPTA Weight (kg)	0 10 20 30 40 50 60 70 80 90 100 110 120 130 140 150 160																	MATERIAL FOR DRILLING			
																						Highly reinforced concrete	Concrete, granite, stone, brick	Metal/wood	Working direction
28mm series	HR2810		3.4 - 3.9	3.2-28 6-20																	✓	✓✓✓	✓	↕	
	SDS-plus			35-80																					Diamond core 32 ~ 80 (dry type)

				EPTA Weight (kg)	0 10 20 30 40 50 60 70 80 90 100 110 120 130 140 150 160																	MATERIAL FOR DRILLING			
																						Highly reinforced concrete	Concrete, granite, stone, brick	Metal/wood	Working direction
32mm series	HR3210C		4.8 - 5.6	4-32 10-22																	✓	✓✓✓	✓	↕	
	SDS-plus			35-90																					Diamond core 32 ~ 90 (dry type)
32mm series	HR3200C		4.8 - 5.6	4-32 10-22																	✓	✓✓✓	✓	↕	
	SDS-plus			35-90																					Diamond core 32 ~ 90 (dry type)

				EPTA Weight (kg)	0 10 20 30 40 50 60 70 80 90 100 110 120 130 140 150 160																	MATERIAL FOR DRILLING			
																						Highly reinforced concrete	Concrete, granite, stone, brick	Metal/wood	Working direction
35mm series	HR3530		5.8	10-35 12-25																	✓✓✓	✓✓✓		↕	
	17mm Hex			25-105																					

				EPTA Weight (kg)	0 10 20 30 40 50 60 70 80 90 100 110 120 130 140 150 160																	MATERIAL FOR DRILLING			
																						Highly reinforced concrete	Concrete, granite, stone, brick	Metal/wood	Working direction
40mm series	HR4013C		6.2 - 6.9	10-40 16-35																	✓✓✓	✓✓✓		↙	
	SDS-max			20-105																					
40mm series	HR4003C		6.2 - 6.9	10-40 16-35																	✓✓✓	✓✓✓		↙	
	SDS-max			20-105																					
40mm series	HR4001C		6.3 - 6.7	10-40 16-35																	✓✓✓	✓✓✓		↙	
	SDS-max			20-105																					
40mm series	HR4002		6.6 - 6.8	10-40 16-32																	✓✓✓	✓✓✓		↙	
	SDS-max			20-105																					
40mm series	HR4030C		6.9	10-40 22-35																	✓✓✓	✓✓✓		↙	
	17mm Hex			25-118																					

				EPTA Weight (kg)	0 10 20 30 40 50 60 70 80 90 100 110 120 130 140 150 160																	MATERIAL FOR DRILLING			
																						Highly reinforced concrete	Concrete, granite, stone, brick	Metal/wood	Working direction
45mm series	HR4511C		8.9 - 9.1	10-45 22-40																	✓✓✓	✓✓✓		↙	
	SDS-max			20-125																					
45mm series	HR4501C		8.9 - 9.1	10-45 22-40																	✓✓✓	✓✓✓		↙	
	SDS-max			20-125																					

				EPTA Weight (kg)	0 10 20 30 40 50 60 70 80 90 100 110 120 130 140 150 160																	MATERIAL FOR DRILLING			
																						Highly reinforced concrete	Concrete, granite, stone, brick	Metal/wood	Working direction
52mm series	HR5212C		11 - 12	19-52 25-45																	✓✓✓	✓✓✓		↙	
	SDS-max			20-160																					
52mm series	HR5202C		11 - 12	19-52 25-45																	✓✓✓	✓✓✓		↙	
	SDS-max			20-160																					
52mm series	HR5211C		11.3 - 12.2	19-52 25-45																	✓✓✓	✓✓✓		↙	
	SDS-max			20-160																					

# CUTTING

Pemotong 切割



## CUTTING (New Material | Masonry | Metal)

### 4112HS 305mm (12")

204 W

#### Angle Cutter

Mesin Pemotong  
切割机



- **Smooth and comfortable cutting**  
Pemotongan lancar dan selesa  
平滑切割

Standard Equipment: **Socket Wrench**



<b>Continuous Rating Input</b> Input Kuasa Berterusan 额定输入功率	2,400W
<b>Capacity</b> Kapasiti 能力	<b>Max cutting : 100mm (4")</b>
<b>Blade Diameter</b> Diameter Bilah 锯片直径	305mm (12")
<b>No Load Speed (RPM)</b> Kelajuan Tanpa Beban 回转数	5,000
<b>Overall Length</b> Panjang Keseluruhan 总长度	648mm (25-1/2")
<b>Net Weight</b> Berat Bersih 净重	10.4kg (22.9lbs)
<b>Power Supply Cord</b> Kabel Wayar 电源线	2.5m (8.2ft)

### 4114S 355mm (14")

204 W

#### Angle Cutter

Mesin Pemotong  
切割机



- **Faster cutting for increased productivity**  
Pemotongan cepat meningkatkan produktiviti  
更快的切割提高生产力

Standard Equipment: **Wrench**



<b>Continuous Rating Input</b> Input Kuasa Berterusan 额定输入功率	2,400W
<b>Capacity</b> Kapasiti 能力	<b>Max cutting : 125mm (5")</b>
<b>Wheel Diameter</b> Diameter Bilah 锯片直径	355mm (14")
<b>Hole Diameter</b> Diameter Lubang 孔直径	25.4mm (1")
<b>No Load Speed (RPM)</b> Kelajuan Tanpa Beban 回转数	3,500
<b>Dimensions (L x W x H)</b> Dimensi 体积	673x240x329mm (26-1/2"x9-1/2"x13")
<b>Net Weight</b> Berat Bersih 净重	10.8kg (23.9lbs)
<b>Power Supply Cord</b> Kabel Wayar 电源线	2.5m (8.2ft)

### SG1251J 125mm (5")

318 W

#### Wall Chaser

Mesin Pemotong Dinding  
石材开槽切割机



- **Clean, compact and comfortable**  
Bersih, padat dan selesa  
干净, 紧凑, 舒适

Standard Equipment: **Diamond Wheel x2, Hex Wrench,  
Lock Nut Wrench**



<b>Continuous Rating Input</b> Input Kuasa Berterusan 额定输入功率	1,400W
<b>Capacity</b> Kapasiti 能力	<b>Depth : 0-30mm (0 - 1-3/16") Width: 6-30mm (1/4 - 1-3/16")</b>
<b>Blade Diameter</b> Diameter Bilah 锯片直径	125mm (5")
<b>No Load Speed (RPM)</b> Kelajuan Tanpa Beban 回转数	10,000
<b>Dimensions (L x W x H)</b> Dimensi 体积	350x151x178mm (13-3/4"x5-15/16"x7")
<b>Net Weight</b> Berat Bersih 净重	4.3kg (9.5lbs)
<b>Power Supply Cord</b> Kabel Wayar 电源线	5.0m (16.4ft)

### 4131 185mm (7-1/4")

303 W

#### Metal Cutter

Mesin Memotong Logam  
金属切割机



- **Powerful 1,100W motor cuts through various types of metal**  
Motor berkuasa 1,100W sesuai untuk memotong pelbagai jenis logam  
强力1,100W马达可切割多种金属

Standard Equipment: **Carbide-Tipped Saw Blade (B-04628),  
Hex Wrench, Safety Goggles**



<b>Continuous Rating Input</b> Input Kuasa Berterusan 额定输入功率	1,100W
<b>Blade Diameter</b> Diameter Bilah 锯片直径	185mm (7-1/4")
<b>Capacity</b> Kapasiti 能力	<b>Max cutting : 63mm (2-1/2")</b>
<b>No Load Speed (RPM)</b> Kelajuan Tanpa Beban 回转数	3,500
<b>Overall Length</b> Panjang Keseluruhan 总长度	358mm (14-1/8")
<b>Net Weight</b> Berat Bersih 净重	4.8kg (11.3lbs)
<b>Power Supply Cord</b> Kabel Wayar 电源线	2.5m (8.2ft)

# CUTTING (New Material | Masonry)

## 4100NH 110mm (4-3/8")

303

### Cutter

Mesin Pemotong  
切割机



- **Powerful cutting in stone, masonry, tile & concrete**  
Berkuasa untuk memotong batu, masonri, jubin & konkrit  
有力的切割石材, 砖石, 瓷砖和混凝土

Standard Equipment: Wrench, Socket Wrench



<b>Continuous Rating Input</b> Input Kuasa Berterusan 额定输入功率	1,300W
<b>Blade Diameter</b> Diameter Bilah 锯片直径	110mm (4-3/8")
<b>Max Cutting Capacity</b> Kapasiti Pemotongan Maksimum 最大切割能力	90°: 34mm (1-3/8")
<b>No Load Speed (RPM)</b> Kelajuan Tanpa Beban 回转数	14,500
<b>Dimensions (L x W x H)</b> Dimensi 体积	234x210x165mm (9-1/4"x8-1/4"x6-1/2")
<b>Net Weight</b> Berat Bersih 净重	2.9kg (6.5lbs)
<b>Power Supply Cord</b> Kabel Wayar 电源线	2.5m (8.2ft)

## 4100NH2Z 110mm (4-3/8")

303

### Cutter

Mesin Pemotong  
切割机



- **Bevel-cuts up to 45 degrees**  
Potongan serong hingga 45°  
45° 斜角切割

Standard Equipment: Wrench, Hex Wrench



<b>Continuous Rating Input</b> Input Kuasa Berterusan 额定输入功率	1,400W
<b>Blade Diameter</b> Diameter Bilah 锯片直径	Max 125mm (Max 5")
<b>Max Cutting Capacity w/ 110mm (4-3/8") wheel</b> Kapasiti Pemotongan Maksimum 最大切割能力	90°: 32.5mm (1-1/4") 45°: 21.5mm (7/8")
<b>Max Cutting Capacity w/ 125mm (5") wheel</b> Kapasiti Pemotongan Maksimum 最大切割能力	90°: 40.0mm (1-9/16") 45°: 27.0mm (1-1/16")
<b>No Load Speed (RPM)</b> Kelajuan Tanpa Beban 回转数	12,200
<b>Dimensions (L x W x H)</b> Dimensi 体积	238x214x169mm (9-3/8"x8-3/8"x6-5/8")
<b>Net Weight</b> Berat Bersih 净重	3kg (6.6lbs)
<b>Power Supply Cord</b> Kabel Wayar 电源线	2.5m (8.2ft.)

## 4100NH3Z 110mm (4-3/8")

303

### Cutter

Mesin Pemotong  
切割机



- **Specialized for right angle cutting only**  
Khusus untuk pemotongan sudut kanan sahaja  
专为右斜角切割而设

Standard Equipment: Wrench, Hex Wrench



<b>Continuous Rating Input</b> Input Kuasa Berterusan 额定输入功率	1,300W
<b>Blade Diameter</b> Diameter Bilah 锯片直径	110mm (4-3/8")
<b>Max Cutting Capacity</b> Kapasiti Pemotongan Maksimum 最大切割能力	90°: 32mm (1-1/4")
<b>No Load Speed (RPM)</b> Kelajuan Tanpa Beban 回转数	13,800
<b>Dimensions (L x W x H)</b> Dimensi 体积	227x209x166mm (8-15/16"x8-1/4"x6-1/2")
<b>Net Weight</b> Berat Bersih 净重	2.8kg (6.2lbs)
<b>Power Supply Cord</b> Kabel Wayar 电源线	2.0m (6.6ft.)

## 4100KB 125mm (5")

303

### Dustless Cutter

Mesin Pemotong  
切割机



- **Powerful 1,400W motor, cutting in stone, masonry, tile, concrete & more**  
Motor berkuasa 1,400W, untuk memotong batu, masonri, jubin, konkrit dll  
强力1,400W马达适合切割石材, 砖石, 瓷砖, 混凝土等

Standard Equipment: Diamond Wheel (D-38261),  
Dust Bag (1267380), Wrench, Hex Wrench



<b>Continuous Rating Input</b> Input Kuasa Berterusan 额定输入功率	1,400W
<b>Blade Diameter</b> Diameter Bilah 锯片直径	125mm (5")
<b>Max Cutting Capacity</b> Kapasiti Pemotongan Maksimum 最大切割能力	40.0mm (1-9/16")
<b>No Load Speed (RPM)</b> Kelajuan Tanpa Beban 回转数	12,200
<b>Dimensions (L x W x H)</b> Dimensi 体积	231x220x179mm (9-1/8"x8-5/8"x7")
<b>Net Weight</b> Berat Bersih 净重	3.0kg (6.6lbs.)
<b>Power Supply Cord</b> Kabel Wayar 电源线	2.5m (8.2ft.)

## 4107R 180mm (7-1/8")

153

### Cutter

Mesin Pemotong  
切割机



- **Ideal for stone materials (such as granite and marble), concrete and asphalt**  
Sesuai untuk bahan batu seperti granit, marmo, konkrit dan asfalt bahan  
适用于石材如花岗岩, 大理石, 混凝土和沥青

Standard Equipment: Socket Wrench, Offset Wrench,  
Water plug & tube



<b>Continuous Rating Input</b> Input Kuasa Berterusan 额定输入功率	1,400W
<b>Capacity</b> Kapasiti 能力	Max cutting : 60mm (2-3/8")
<b>Blade Diameter</b> Diameter Bilah 锯片直径	180mm (7-1/8")
<b>No Load Speed (RPM)</b> Kelajuan Tanpa Beban 回转数	5,000
<b>Overall Length</b> Panjang Keseluruhan 总长度	370mm (14-9/16")
<b>Net Weight</b> Berat Bersih 净重	6.3kg (14.5lbs)
<b>Power Supply Cord</b> Kabel Wayar 电源线	5.0m (16.4ft)

Cordless  
Tepat Kod 无线电

LED Flashlight  
Lampu Suhu LED  
LED 闪光灯

Vacuum Cleaner  
Pembersih Vakuum  
吸尘器

Drilling | Fastening  
Cairul | Pengikat  
钻孔 | 紧固

Impact Drilling | Demolition  
Cairul | Penceroboh  
冲击钻孔 | 拆除施工

Cutting  
Pemotong  
切割

Grinding | Sanding  
Pengijil | Palsan  
打磨 | 砂磨

Sawing  
Gergaji  
锯切

Planing | Routing  
Pengijil | Tanggapan  
刨削 | 雕刻

Others  
Lain-lain  
其他

Outdoor Power Equipment  
Alatan Kuasa Luar  
户外动力设备

Makita  
MAKITA

# CUTTING (New Material | Masonry | Metal)

**LC1230** 305mm (12")

203

**Metal Cutting Saw**  
Mesin Memotong Logam  
金属型材切割机



- For Cutting in Pipe, Angle Iron, Conduit and More  
Untuk pemotongan paip, sesiku besi, konduit dan banyak lagi  
用于切割管道, 角铁, 导管等

**Standard Equipment:** Carbide-Tipped Saw Blade, Socket Wrench, Safety Goggles



<b>Continuous Rating Input</b> Input Kuasa Berterusan 额定输入功率	1,750W
<b>Blade Diameter</b> Diameter Bilah 锯片直径	305mm (12")
<b>Max Cutting Capacity</b> Kapasiti Pemotongan Maksimum 最大切割能力	90°: 115mm (4-1/2") 90°: 75 x 150mm (2-15/16" x 5-7/8") 45°: 90mm (3-1/2") 45°: 85 x 85mm (3-5/16" x 3-5/16")
<b>No Load Speed (RPM)</b> Kelajuan Tanpa Beban 回转数	1,300
<b>Dimensions (L x W x H)</b> Dimensi 体积	516x306x603mm (20-1/4"x12"x23-3/4")
<b>Net Weight</b> Berat Bersih 净重	19.3kg (42.5lbs)
<b>Power Supply Cord</b> Kabel Wayar 电源线	2.5m (8.2ft)

## Why Makita Carbide-tipped Metal Cutting saw VS. Abrasive Cutting Saw



Carbide-Tipped Blades make Virtually Spark-Free Cuts

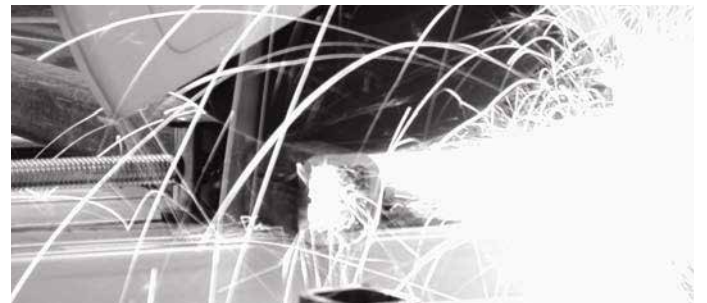

Abrasive Blades make Cuts with Sparks

## Makita's Carbide-Tipped Metal Blades Cuts Cleaner

Tubing	Threaded Rod	UNISTRUT™	Angle Iron	Pipe
<b>Makita Carbide-Tipped Blade</b>	<b>Makita Carbide-Tipped Blade</b>	<b>Makita Carbide-Tipped Blade</b>	<b>Makita Carbide-Tipped Blade</b>	<b>Makita Carbide-Tipped Blade</b>
Abrasive Blade	Abrasive Blade	Abrasive Blade	Abrasive Blade	Abrasive Blade

## Carbide-Tipped Metal Blades for Many Applications

Applications				Angle		Tubing		Channel		Round Pipe	Stainless Angle	Stainless Tubing
Size (mm)	Tip thickness	Part No.	Nominal thickness	6mm	4mm	3mm	4.5mm	2.3mm	3.2mm	3.8mm	4mm	1.5mm
305 x 60T (Mild steel)	2.1mm	A-87242		○	○	○	△	×	◎	◎	×	×
305 x 60T (Mild steel)	2.5mm	A-81860		○	○	◎	○	×	◎	◎	×	×
305 x 60T (Mild steel) lessend noise	2.4mm	A-86723		◎	◎	◎	○	×	◎	◎	×	×
305 x 78T (Thin steel)	2.3mm	A-87127		△	△	△	×	○	△	△	×	×
305 x 76T (Stainless)	1.95mm	A-87579		○	○	△	×	◎	△	◎	○	○

Cordless 无绳式  
LED Flashlight 内置LED灯  
Vacuum Cleaner 吸尘器  
Drilling / Fastening 钻孔 / 紧固  
Impact Drilling / Demolition 冲击钻孔 / 拆除加工  
Cutting 切割  
Grinding / Sanding 研磨 / 打磨  
Sawing 锯切  
Planing / Routing 刨削 / 铣削  
Others 其他  
Outdoor Power Equipment 户外动力设备



# CUTTING (New Material | Masonry | Metal)

## Metal Cutting Process

### Carbide-Tipped Metal Blade Cutting Tips

- Always wear safety glasses, gloves, protective equipment and follow instructions provided with power tool
- Do not apply excessive pressure on the handle when cutting as damage to the carbide-tips can be a result
- Too little or too much pressure on the handle may result in more sparks and premature blade wear
- Use block spacers when cutting square/rectangle tubing as well as channel and UNISTRUT™ for longer blade life
- When cutting long pieces of metal always use support blocks on both sides so the metal will be level with the saw base
- Do not touch blade or metal immediately after cut

### Carbide-Tipped Metal Blade Cutting Tips

- 1 Ensure metal is properly placed on saw base and firmly secured in the saw
- 2 Hold the saw handle firmly and wait until full speed is obtained
- 3 Lower the handle gently to bring the blade close to the metal
- 4 Gently ease the blade into the metal and add minimal pressure (reduce pressure if sparks appear)
- 5 After completed cut, turn off power tool and wait until blade has come to a complete stop then raise the handle back (if handle is raised back with blade still rotating then the blade may be caught)

### Metal Cutting Process

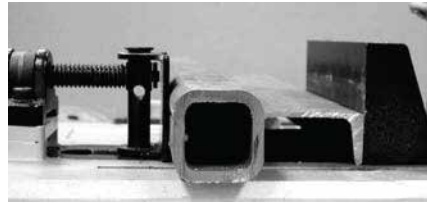

Square & Rectangle Tubing (use block spacer)

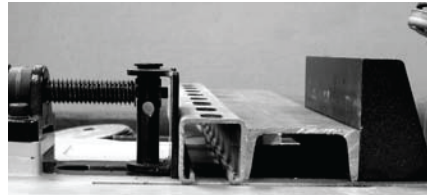

Channels & UNISTRUT™ (use block spacer)

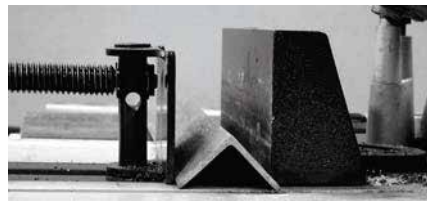

Angle

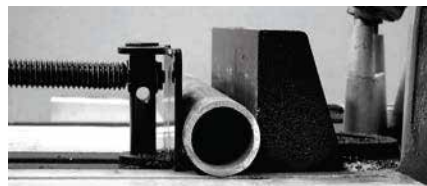

Round Pipe

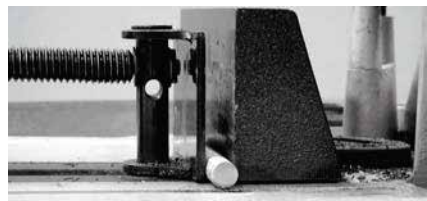

Threaded Rod

## Block Spacer Reference Chart

Applications	Square & Rectangle Tubing				Round Pipe		Square & Rectangle Tubing		Round Pipe		
	Up to 75 mm		Up to 100 mm		—		Up to 85 mm		—		
The height of material	A	B	A	B	A	B	A	B	A	B	
<p>Block Spacer</p> <p>Material</p> <p>A B</p> <p>(mm)</p>	90 Degree Cutting	25	125	25	75	25	90	25	60	25	65
		50	100	50	50	50	65	50	35	50	40
		75	75	75	25	75	40	75	10	75	15
		100	50	100	0	100	15	85	0	90	0
		125	25	—	—	115	0	—	—	—	—
		*150	0	—	—	—	—	—	—	—	—
	45 Degree Cutting										

\*Hint: Block Spacer should be determined by subtracting the metal width from 150 mm.

Cordless  
Target Model 10.8V

LED Flashlight  
Lampu Saku LED  
LED03B02

Vacuum Cleaner  
Penyedot Vakum  
020301

Drilling / Fastening  
Cairan / Pengikat  
020301

Impact Drilling / Demolition  
Cairan / Perusak  
020301

Cutting  
Pemotong  
020301

Grinding / Sanding  
Pengkilan / Pasir  
020301

Sawing  
Gergaji  
020301

Planing / Routing  
Pengkilan / Tumpang  
020301

Others  
Lain-lain  
020301

Outdoor Power Equipment  
Alat-alat Luar  
020301

Makita  
1946

# CUTTING (Metal)

Cordless  
Tangki food 充电式

LED Flashlight  
Lampu Suhu LED  
LED 照明灯

Vacuum Cleaner  
Pembersih Vakum  
吸尘器

Drilling / Fastening  
Gardu / Pengikat  
钻孔 / 紧固

Impact Drilling / Demolition  
Gardu / Pemecah  
起工钻孔 / 拆墙加工

Cutting  
Pemotong  
切割

Grinding / Sanding  
Pengkilan / Pasiran  
打磨 / 砂磨

Sawing  
Gergaji  
锯切

Planing / Routing  
Pengaliran / Tunggaman  
刨削 / 雕刻

Others  
Lain-lain  
其他

Outdoor Power Equipment  
Alat-alat Kerja Luar  
户外动力设备

Makita  
Makita



## 2107F

### Portable Band Saw Pemotong Ringan 轻便带锯



- Built-in fluorescent job light for clear view  
Lampu kerja fluoresen terbina dalam untuk penglihatan jelas  
内置荧光工作灯，确保清晰视野

#### ACCESSORIES (Optional)



Standard Equipment:  
Band Saw Blade, Hex Wrench



Portable Band Saw  
Stand & Cover  
Part No. 196326-7

303

<b>Continuous Rating Input</b> Input Kuasa Berterusan 额定输入功率	710W
<b>Capacity</b> Kapasiti 能力	Round: 120mm (4-3/4") Rectangular workpiece w/o stand: 120x120mm (4-3/4"x4-3/4")
<b>Blade Speed</b> Kelajuan Bilah 刀片速度	60m (200ft) - 105m (350ft) / min
<b>Dimensions (L x W x H)</b> Dimensi 体积	508x188x256mm (20"x7-3/8"x10-1/8")
<b>Net Weight</b> Berat Bersih 净重	6.3kg (13.9lbs)
<b>Power Supply Cord</b> Kabel Wayar 电源线	2.5m (8.2ft)

## LW1400 355mm (14")

### Portable Cut-off Mesin Pemotong 型材切割机



- Large spark guard prevents backward scattering of spark  
Pengawal pencucuh menghalang hamburan mundur dari percikan api  
大的火花防护装置可防止火花向后散射

Standard Equipment: Abrasive Cut-Off Wheel



203

<b>Continuous Rating Input</b> Input Kuasa Berterusan 额定输入功率	2,200W
<b>Wheel Diameter</b> Diameter Bilah 锯片直径	355mm (14")
<b>No Load Speed (RPM)</b> Kelajuan Tanpa Beban 回转数	3,800
<b>Capacity at 45°</b> Kapasiti 能力	Round: 127mm (5") Rectangular: 115x103mm (4-1/2"x4-1/16") Square: 106x106mm (4-3/16"x4-3/16") Triangular: 100x100x10mm (4"x4"x3/8")
<b>Dimensions (L x W x H)</b> Dimensi 体积	530x295x640mm (20-7/8"x11-5/8"x25-1/4")
<b>Net Weight</b> Berat Bersih 净重	18.7kg (41.2lbs)
<b>Power Supply Cord</b> Kabel Wayar 电源线	2.5m (8.2ft)

## LW1401 355mm (14")

### Portable Cut-off Mesin Pemotong 型材切割机



- Powerful 2,200W motor  
Motor berkuasa 2,200W  
强力2200W马达

Standard Equipment: Abrasive Cut-Off Wheel, Socket Wrench



203

<b>Continuous Rating Input</b> Input Kuasa Berterusan 额定输入功率	2,200W
<b>Wheel Diameter</b> Diameter Bilah 锯片直径	355mm (14")
<b>No Load Speed (RPM)</b> Kelajuan Tanpa Beban 回转数	3,800
<b>Capacity at 45°</b> Kapasiti 能力	Round: 127mm (5") Rectangular: 115x103mm (4-1/2"x4-1/16") Square: 106x106mm (4-3/16"x4-3/16") Triangular: 100x100x10mm (4"x4"x3/8")
<b>Dimensions (L x W x H)</b> Dimensi 体积	500x295x640mm (19-3/4"x11-5/8"x25-1/4")
<b>Net Weight</b> Berat Bersih 净重	18.3kg (40.3lbs)
<b>Power Supply Cord</b> Kabel Wayar 电源线	2.5m (8.2ft)

Makita  
Makita

# CUTTING (Metal)

## 2416S 405mm (16")

**Portable Cut-off**  
Mesin Pemotong  
型材切割机



- **Mitres 45° Left And Right**  
Potongan miter 45° kiri dan kanan  
左右45°斜切割



Standard Equipment: Abrasive Cut-Off Wheel, Socket Wrench

153 mm

<b>Continuous Rating Input</b> Input Kuasa Berterusan 额定输入功率	1,430W
<b>Wheel Diameter</b> Diameter Bilah 锯片直径	405mm (16")
<b>Hole Diameter</b> Diameter Lubang 孔直径	25.4mm (1")
<b>No Load Speed (RPM)</b> Kelajuan Tanpa Beban 回转数	2,300
<b>Dimensions (L x W x H)</b> Dimensi 体积	610x265x535mm (24"x10-3/8"x21")
<b>Net Weight</b> Berat Bersih 净重	19.2kg (42.3lbs)
<b>Power Supply Cord</b> Kabel Wayar 电源线	2.5m (8.2ft)

Model No. 型号	Cutting Angle Sudut Pemotongan 切割角度	Round Pipe Tiub Bulat 圆管	Rectangular Metal Logam Segi Empat Tepat 长方形金属	Square Metal Logam Segi Empat 方形金属	Angle Bar Besi Sudut 角铁
LC1230	90°	115mm	150 x 75mm	100mm	100mm
	45°	90mm	85 x 85mm	85mm	85mm
LW1400	90°	127mm	233 x 70mm	119mm	137mm
	45°	127mm	115 x 103mm	106mm	100mm
LW1401	90°	127mm	233 x 70mm	119mm	137mm
	45°	127mm	115 x 103mm	106mm	100mm
2416S	90°	115mm	230 x 80mm	120mm	150mm
	45°	115mm	110 x 110mm	110mm	110mm

## JN1601 1.6mm (16Ga)

**Nibbler**  
Pemotong Elektrik  
电冲剪



- **2,200 SPM for faster and smooth cutting**  
2,200 SPM untuk pemotongan cepat dan lancar  
2200 SPM更快更顺畅地切割



Standard Equipment: Hex Wrench, Wrench, Punch, Die

411 mm

<b>Continuous Rating Input</b> Input Kuasa Berterusan 额定输入功率	550W
<b>Capacity</b> Kapasiti 能力	Steel up to 400 N/mm <sup>2</sup> : 1.6mm Steel up to 600 N/mm <sup>2</sup> : 1.2mm Steel up to 800 N/mm <sup>2</sup> : 0.8mm Aluminum up to 200 N/mm <sup>2</sup> : 2.5mm
<b>Min. Cutting Radius</b> Radius Pemotongan Minimum 最小切割半径	Outside edge : 50mm (2") Inside edge : 45mm (1-3/4")
<b>Strokes Per Minute (SPM)</b> Kelajuan Strok 冲程速度	2,200
<b>Overall Length</b> Panjang Keseluruhan 总长度	261mm (10-1/4")
<b>Net Weight</b> Berat Bersih 净重	1.6kg (3.6lbs)
<b>Power Supply Cord</b> Kabel Wayar 电源线	2.0m (6.6ft)



## JN3201 3.2mm (10Ga)

**Nibbler**  
Pemotong Elektrik  
电冲剪



- **Built-in thickness gauge for operator convenience**  
Penyukat ketebalan terbina dalam memudahkan pengguna  
内置厚度仪方便使用



Standard Equipment:  
Punch, Die, Wrench 50, Hex Wrench, Washer

303 mm

<b>Continuous Rating Input</b> Input Kuasa Berterusan 额定输入功率	710W
<b>Capacity</b> Kapasiti 能力	Steel up to 400 N/mm <sup>2</sup> : 3.2mm Steel up to 600 N/mm <sup>2</sup> : 2.5mm Steel up to 800 N/mm <sup>2</sup> : 1.0mm Aluminum up to 200 N/mm <sup>2</sup> : 3.5mm
<b>Min. Cutting Radius</b> Radius Pemotongan Minimum 最小切割半径	Outside edge : 128mm (5-1/16") Inside edge : 120mm (4-3/4")
<b>Strokes Per Minute (SPM)</b> Kelajuan Strok 冲程速度	1,300
<b>Dimensions (L x W x H)</b> Dimensi 体积	225x90x254mm (8-7/8"x1-1/2"x10")
<b>Net Weight</b> Berat Bersih 净重	3.4kg (7.4lbs)
<b>Power Supply Cord</b> Kabel Wayar 电源线	2.5m (8.2ft)



Cordless  
Tepat Kecek 充电式

LED Flashlight  
Lampu Suluh LED  
LED照明灯

Vacuum Cleaner  
Pembersih Vakuum  
吸尘器

Drilling | Fastening  
Cepat | Pasang  
钻孔 | 紧固

Impact Drilling | Demolition  
Gertak | Pecutan  
打桩机 | 拆除工具

Cutting  
Pemotong  
切割

Grinding | Sanding  
Pengkilan | Palsan  
打磨 | 砂磨

Sawing  
Gergaji  
锯切

Planing | Routing  
Pengkilan | Tinggung  
刨削 | 雕刻

Others  
Lain-lain  
其他

Outdoor Power Equipment  
Alatan Kuasa Luar  
户外动力工具



# CUTTING (Metal)

## JS1601 1.6mm (16Ga)

459 

### Straight Metal Shear

Pemotong Elektrik  
电剪刀



- **Fast Cutting Action in Steel and Aluminum**  
Pemotongan Cepat untuk Keluli dan Aluminium  
快速切割钢和铝



Standard Equipment: Hex Wrench, Thickness Gauge



<b>Continuous Rating Input</b> Input Kuasa Berterusan 额定输入功率	380W
<b>Capacity</b> Kapasiti 能力	Steel up to 400N/mm <sup>2</sup> : 1.6mm Steel up to 600N/mm <sup>2</sup> : 1.2mm Steel up to 800N/mm <sup>2</sup> : 0.8mm Aluminum up to 200N/mm <sup>2</sup> : 2.5mm 250mm (9-7/8")
<b>Min. Cutting Radius</b> Radius Pemotongan Minimum 最小切割半径	
<b>Strokes Per Minute (SPM)</b> Kelajuan Strok 冲程速度	4,500
<b>Dimensions (L x W x H)</b> Dimensi 体积	320x70x78mm (12-5/8"x2-3/4"x3-1/16")
<b>Net Weight</b> Berat Bersih 净重	1.4kg (3.2lbs)
<b>Power Supply Cord</b> Kabel Wayar 电源线	2.5m (8.2ft)

## JS1300 1.3mm

419 

### Straight Shear

Pemotong Elektrik  
电剪刀



- **Shear head attachment rotates 360°**  
Kepala pemotong boleh berputar 360°  
剪切头附件可旋转360°



Standard Equipment: Hex Wrench



<b>Continuous Rating Input</b> Input Kuasa Berterusan 额定输入功率	570W
<b>Capacity</b> Kapasiti 能力	Steel up to 400N/mm <sup>2</sup> : 1.3mm Steel up to 600N/mm <sup>2</sup> : 1.0mm Steel up to 800N/mm <sup>2</sup> : 0.5mm Aluminum up to 200N/mm <sup>2</sup> : 2.5mm 0-2,500
<b>Strokes Per Minute (SPM)</b> Kelajuan Strok 冲程速度	0-2,500
<b>Overall Length</b> Panjang Keseluruhan 总长度	302mm (11-7/8")
<b>Net Weight</b> Berat Bersih 净重	1.8kg (3.9lbs)
<b>Power Supply Cord</b> Kabel Wayar 电源线	2.5m (8.2ft)

## JS1602 1.6mm (16Ga)

459 

### Metal Shear

Pemotong Elektrik  
电剪刀



- **Fast and efficient cutting**  
Pemotongan cepat dan cekap  
快速高效的切割



Standard Equipment: Hex Wrench, Shear Blade Set



<b>Continuous Rating Input</b> Input Kuasa Berterusan 额定输入功率	380W
<b>Capacity</b> Kapasiti 能力	Steel up to 400N/mm <sup>2</sup> : 1.6mm Steel up to 600N/mm <sup>2</sup> : 1.2mm Steel up to 800N/mm <sup>2</sup> : 0.8mm Aluminum up to 200N/mm <sup>2</sup> : 2.5mm 30mm (1-3/16")
<b>Min. Cutting Radius</b> Radius Pemotongan Minimum 最小切割半径	
<b>Strokes Per Minute (SPM)</b> Kelajuan Strok 冲程速度	4,000
<b>Dimensions (L x W x H)</b> Dimensi 体积	255x74x146mm (10"x2-15/16"x5-3/4")
<b>Net Weight</b> Berat Bersih 净重	1.6kg (3.4lbs)
<b>Power Supply Cord</b> Kabel Wayar 电源线	2.5m (8.2ft)

## JS3201 3.2mm (10Ga)

303 

### Metal Shear

Pemotong Elektrik  
电剪刀



- **Powerful 710W Motor**  
Motor berkuasa 710W  
强力710W马达



Standard Equipment: Shear Blade Set, Hex Wrench, Thickness Gauge



<b>Continuous Rating Input</b> Input Kuasa Berterusan 额定输入功率	710W
<b>Capacity</b> Kapasiti 能力	Steel up to 400N/mm <sup>2</sup> : 3.2mm Steel up to 600N/mm <sup>2</sup> : 2.5mm Steel up to 800N/mm <sup>2</sup> : 1.5mm Aluminum up to 200N/mm <sup>2</sup> : 4.0mm 50mm (2")
<b>Min. Cutting Radius</b> Radius Pemotongan Minimum 最小切割半径	
<b>Strokes Per Minute (SPM)</b> Kelajuan Strok 冲程速度	1,600
<b>Dimensions (L x W x H)</b> Dimensi 体积	213x90x239mm (8-3/8"x3-1/2"x9-3/8")
<b>Net Weight</b> Berat Bersih 净重	3.4kg (7.5lbs)
<b>Power Supply Cord</b> Kabel Wayar 电源线	2.5m (8.2ft)

## CA5000X 118mm (4-5/8")

303 

### Aluminum Groove Cutter

Mesin Memotong Aluminium  
铝板开槽切割机



- **Cutter blade for 135 degrees V shaped groove as an option**  
Bilah pemotong alur 135° berbentuk V pemilihan  
可选135° V形槽的锯片



Standard Equipment: Cutter Blade, Plate, Hex Wrench

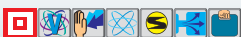

<b>Continuous Rating Input</b> Input Kuasa Berterusan 额定输入功率	1,300W
<b>Blade</b> Bilah 锯片	Type: Cutter blade/ TCT saw blade
<b>Max Cutting Capacity w/ Cutter blade</b> Kapasiti Pemotongan Maksimum 最大切割能力	w/ Guide rail: 11mm (7/16")
<b>Max Cutting Capacity w/ TCT Saw blade</b> Kapasiti Pemotongan Maksimum 最大切割能力	w/ Guide rail: 36mm (1-7/16") w/o Guide rail: 41mm (1-5/8") 2,200-6,400
<b>No Load Speed (RPM)</b> Kelajuan Tanpa Beban 回转数	
<b>Dimensions (L x W x H)</b> Dimensi 体积	346x250x250mm (13-5/8"x9-7/8"x9-7/8")
<b>Net Weight</b> Berat Bersih 净重	4.7kg (10.4lbs)
<b>Power Supply Cord</b> Kabel Wayar 电源线	2.5m (8.2ft)

Cordless  
Tangkas Kuasa BerterusanLED Flashlight  
Lampu Suluh LED  
LED 照明灯Vacuum Cleaner  
Pembersih Vakuum  
吸尘器Drilling / Fastening  
Ganda / Pengikat  
钻孔 / 紧固Impact Drilling / Demolition  
Ganda / Persekit  
钻孔 / 拆除加工Cutting  
Pemotong  
切割Grinding / Sanding  
Pengkilan / Polesan  
研磨 / 砂磨Sawing  
Ganda  
锯切Planing / Routing  
Pengkilan / Tenggang  
刨削 / 雕刻Others  
Lain-lain  
其他Outdoor Power Equipment  
Alatan Kuasa Luar  
户外动力设备Makita  
MAKITA



# GRINDING SANDING

Pengisar | Pelicin 研削 | 研磨



## 9553HNG 100mm (4")

325

### Angle Grinder Pengisar Sudut 角向磨光机



#### Slide Switch

Suis Gelangsar 滑动开关

- **Spiral bevel gears for smoother rotations**  
Gear serong lingkaran untuk putaran yang licin  
螺旋锥齿轮更平滑的旋转



**Standard Equipment:** Depressed Center Wheel (A-80852), Side Grip, Wheel Cover, Lock Nut Wrench



<b>Continuous Rating Input</b> Input Kuasa Berterusan 额定输入功率	710W
<b>Wheel Diameter</b> Diameter Roda 轮片直径	100mm (4")
<b>No Load Speed (RPM)</b> Kelajuan Tanpa Beban 回转数	11,000
<b>Dimensions (L x W x H)</b> Dimensi 体积	258x118x97mm (10-1/8"x4-5/8"x3-13/16")
<b>Net Weight</b> Berat Bersih 净重	1.5 - 1.8kg (3.2 - 4.1lbs)
<b>Power Supply Cord</b> Kabel Wayar 电源线	2.5m (8.2ft.)

## 9553HBG 100mm (4")

325

### Angle Grinder Pengisar Sudut 角向磨光机



#### Toggle Switch

Suis Togol 后盖式开关

- **Compact design and lightweight**  
Reka bentuk padat dan ringan  
设计紧凑, 轻量



**Standard Equipment:** Depressed Center Wheel (A-80852), Wheel Cover, Lock Nut Wrench



<b>Continuous Rating Input</b> Input Kuasa Berterusan 额定输入功率	710W
<b>Wheel Diameter</b> Diameter Roda 轮片直径	100mm (4")
<b>No Load Speed (RPM)</b> Kelajuan Tanpa Beban 回转数	11,000
<b>Dimensions (L x W x H)</b> Dimensi 体积	258x118x97mm (10-1/8"x4-5/8"x3-13/16")
<b>Net Weight</b> Berat Bersih 净重	1.5 - 1.9kg (3.3 - 4.1lbs)
<b>Power Supply Cord</b> Kabel Wayar 电源线	2.5m (8.2ft.)

## GA4030R 100mm (4")

459

### Angle Grinder Pengisar Sudut 角向磨光机



#### Slide Switch

Suis Gelangsar 滑动开关

- **Machined bevel gears provide up to 2x longer service life**  
Gear bevel machined memanjangkan hayat penggunaan 2x lebih lama  
加工锥齿轮延长了长达 2x 的使用寿命



**Standard Equipment:** Depressed Center Wheel (A-80852), Side Grip, Wheel Cover, Lock Nut Wrench



<b>Continuous Rating Input</b> Input Kuasa Berterusan 额定输入功率	720W
<b>Wheel Diameter</b> Diameter Roda 轮片直径	100mm (4")
<b>No Load Speed (RPM)</b> Kelajuan Tanpa Beban 回转数	11,000
<b>Dimensions (L x W x H)</b> Dimensi 体积	266x118x102mm (10-1/2"x4-5/8"x4")
<b>Net Weight</b> Berat Bersih 净重	1.72 - 2.01kg (3.79 - 4.43lbs)
<b>Power Supply Cord</b> Kabel Wayar 电源线	2.5m (8.2ft)

**Cordless**  
Tanpa Kord 无绳式

**LED Flashlight**  
Lampu Suhu LED  
LED照明灯

**Vacuum Cleaner**  
Pembersih Vakuum  
吸尘器

**Drilling / Fastening**  
Cairul / Pengisar  
钻孔 / 紧固

**Impact Drilling / Demolition**  
Cairul / Pengisar  
石工钻孔 / 摧毁动工

**Cutting**  
Pemotong  
切割

**Grinding / Sanding**  
Pengisar / Pelicin  
研削 / 研磨

**Sanding / Grind**  
磨光

**Planing / Routing**  
Pengisar / Tunggam  
刨削 / 雕刻

**Others**  
Lain-lain  
其他

**Outdoor Power Equipment**  
Alatan Kuat Luar  
园林户外

**Makita**  
工具之王

# GRINDING | SANDING

## GA4030 100mm (4")

459 

### Angle Grinder Pengisar Sudut 角向磨光机



#### Slide Switch

Suis Gelangsar 滑动开关

- All ball bearing construction for durability and longer tool life  
Struktur galas bola untuk memanjangkan hayat alat  
滚珠轴承结构延长工具寿命



**Standard Equipment:** Depressed Center Wheel (A-80852), Side Grip, Wheel Cover, Lock Nut Wrench



<b>Continuous Rating Input</b> Input Kuasa Berterusan 额定输入功率	720W
<b>Wheel Diameter</b> Diameter Roda 轮片直径	100mm (4")
<b>No Load Speed (RPM)</b> Kelajuan Tanpa Beban 回转速数	11,000
<b>Dimensions (L x W x H)</b> Dimensi 体积	266x117x95mm (10-1/2"x4-5/8"x3-3/4")
<b>Net Weight</b> Berat Bersih 淨重	1.73 - 2.02kg (3.81 - 4.45lbs)
<b>Power Supply Cord</b> Kabel Wayar 电源线	2.5m (8.2ft)

## GA4031 100mm (4")

459 

### Angle Grinder Pengisar Sudut 角向磨光机



#### Toggle Switch

Suis Togol 后置式开关

- Toggle switch for easy operation  
Suis togol untuk operasi lebih mudah  
后置式开关方便操作



**Standard Equipment:** Depressed Center Wheel (A-80852), Wheel Cover, Lock Nut Wrench



<b>Continuous Rating Input</b> Input Kuasa Berterusan 额定输入功率	720W
<b>Wheel Diameter</b> Diameter Roda 轮片直径	100mm (4")
<b>No Load Speed (RPM)</b> Kelajuan Tanpa Beban 回转速数	11,000
<b>Dimensions (L x W x H)</b> Dimensi 体积	259x118x104mm (10-1/4"x4-5/8"x4-1/8")
<b>Net Weight</b> Berat Bersih 淨重	1.71 - 2.00kg (3.77 - 4.41lbs)
<b>Power Supply Cord</b> Kabel Wayar 电源线	2.5m (8.2ft)

## GA4034 100mm (4")

459 

### Angle Grinder Pengisar Sudut 角向磨光机



#### Paddle Switch

Suis Pemicu 扳机开关

- Machined bevel gears provide up to 2x longer service life  
Gear bevel machined memanjangkan hayat penggunaan 2x lebih lama  
加工锥齿轮延长了长达 2x 的使用寿命



**Standard Equipment:** Depressed Center Wheel (A-80852), Side Grip, Wheel Cover, Lock Nut Wrench



<b>Continuous Rating Input</b> Input Kuasa Berterusan 额定输入功率	720W
<b>Wheel Diameter</b> Diameter Roda 轮片直径	100mm (4")
<b>No Load Speed (RPM)</b> Kelajuan Tanpa Beban 回转速数	11,000
<b>Dimensions (L x W x H)</b> Dimensi 体积	265x118x95mm (10-3/8"x4-5/8"x3-3/4")
<b>Net Weight</b> Berat Bersih 淨重	1.77 - 2.06kg (3.90 - 4.54lbs)
<b>Power Supply Cord</b> Kabel Wayar 电源线	2.5m (8.2ft)

## 9556HNG / HN / NB 100mm (4")

325 

### Angle Grinder Pengisar Sudut 角向磨光机



#### Slide Switch

Suis Gelangsar 滑动开关

- Powerful 840W motor  
Motor berkuasa 840W  
强力840W马达



**Standard Equipment:** Depressed Center Wheel (A-80852), Side Grip, Wheel Cover, Lock Nut Wrench



<b>Continuous Rating Input</b> Input Kuasa Berterusan 额定输入功率	840W
<b>Wheel Diameter</b> Diameter Roda 轮片直径	100mm (4")
<b>No Load Speed (RPM)</b> Kelajuan Tanpa Beban 回转速数	11,000
<b>Dimensions (L x W x H)</b> Dimensi 体积	271x118x97mm (10-5/8"x4-5/8"x3-13/16")
<b>Net Weight</b> Berat Bersih 淨重	1.6 - 2.0kg (3.6 - 4.4lbs)
<b>Power Supply Cord</b> Kabel Wayar 电源线	2.5m (8.2ft.)

## 9556HPG / PB 100mm (4")

325 

### Angle Grinder Pengisar Sudut 角向磨光机



#### Paddle Switch

Suis Pemicu 扳机开关

- Powerful 840W motor  
Motor berkuasa 840W  
强力840W马达



**Standard Equipment:** Depressed Center Wheel (A-80852), Side Grip, Wheel Cover, Lock Nut Wrench



<b>Continuous Rating Input</b> Input Kuasa Berterusan 额定输入功率	840W
<b>Wheel Diameter</b> Diameter Roda 轮片直径	100mm (4")
<b>No Load Speed (RPM)</b> Kelajuan Tanpa Beban 回转速数	11,000
<b>Dimensions (L x W x H)</b> Dimensi 体积	273x118x97mm (10-3/4"x4-5/8"x3-13/16")
<b>Net Weight</b> Berat Bersih 淨重	1.6 - 2.0kg (3.6 - 4.5lbs)
<b>Power Supply Cord</b> Kabel Wayar 电源线	2.5m (8.2ft.)

# GRINDING | SANDING

## GA4040 100mm (4") 325 mm

**Angle Grinder**  
Pengisar Sudut  
角向磨光机



**Slide Switch**  
Suis Gelangsar 滑动开关

- **Spiral bevel gears for smoother rotations and a more efficient transfer of energy**  
gear serong lingkaran untuk pemindahan tenaga yang lebih cekap  
螺旋锥齿轮高效输送能源



**Standard Equipment:** Depressed Center Wheel (A-80852), Side Grip, Wheel Cover, Lock Nut Wrench



<b>Continuous Rating Input</b> Input Kuasa Berterusan 额定输入功率	1,100W
<b>Wheel Diameter</b> Diameter Roda 轮片直径	100mm (4")
<b>No Load Speed (RPM)</b> Kelajuan Tanpa Beban 回转数	11,000
<b>Dimensions (L x W x H)</b> Dimensi 体积	303x117x111mm (11-7/8"x4-5/8"x4-3/8")
<b>Net Weight</b> Berat Bersih 净重	2.2 - 2.5kg (4.9 - 5.6lbs)
<b>Power Supply Cord</b> Kabel Wayar 电源线	2.5m (8.2ft)

## GA4041C 100mm (4") 318 mm

**Angle Grinder**  
Pengisar Sudut  
角向磨光机



**Slide Switch**  
Suis Gelangsar 滑动开关

- **Super Joint System II developed for effective vibration absorption**  
SJS generasi kedua berkesan untuk menyerap getaran  
第二代 SJS 有效抑止震动



**Standard Equipment:** Depressed Center Wheel (A-80852), Side Grip, Wheel Cover, Lock Nut Wrench



<b>Continuous Rating Input</b> Input Kuasa Berterusan 额定输入功率	1,400W
<b>Wheel Diameter</b> Diameter Roda 轮片直径	100mm (4")
<b>No Load Speed (RPM)</b> Kelajuan Tanpa Beban 回转数	2,800-11,000
<b>Dimensions (L x W x H)</b> Dimensi 体积	325x117x117mm (12-3/4"x4-5/8"x4-5/8")
<b>Net Weight</b> Berat Bersih 净重	2.5 - 2.8kg (5.6 - 6.2lbs)
<b>Power Supply Cord</b> Kabel Wayar 电源线	2.5m (8.2ft)

## GA4040C 100mm (4") 318 mm

**Angle Grinder**  
Pengisar Sudut  
角向磨光机



**Slide Switch**  
Suis Gelangsar 滑动开关

- **Super Joint System II developed for effective vibration absorption**  
SJS generasi kedua berkesan untuk menyerap getaran  
第二代 SJS 有效抑止震动



**Standard Equipment:** Depressed Center Wheel (A-80852), Side Grip, Wheel Cover, Lock Nut Wrench



<b>Continuous Rating Input</b> Input Kuasa Berterusan 额定输入功率	1,400W
<b>Wheel Diameter</b> Diameter Roda 轮片直径	100mm (4")
<b>No Load Speed (RPM)</b> Kelajuan Tanpa Beban 回转数	2,800-11,000
<b>Dimensions (L x W x H)</b> Dimensi 体积	303x117x111mm (11-7/8"x4-5/8"x4-3/8")
<b>Net Weight</b> Berat Bersih 净重	2.3 - 2.6kg (5.1 - 5.7lbs)
<b>Power Supply Cord</b> Kabel Wayar 电源线	2.5m (8.2ft)

## 9563C 100mm (4") 318 mm

**Angle Grinder**  
Pengisar Sudut  
角向磨光机



**Slide Switch**  
Suis Gelangsar 滑动开关

- **High power anti-dust motor**  
Motor tahan debu tinggi  
大功率防尘马达



**Standard Equipment:** Depressed Center Wheel (D-18443), Side Grip, Wheel Cover, Lock Nut Wrench



<b>Continuous Rating Input</b> Input Kuasa Berterusan 额定输入功率	1,400W
<b>Wheel Diameter</b> Diameter Roda 轮片直径	100mm (4")
<b>No Load Speed (RPM)</b> Kelajuan Tanpa Beban 回转数	12,000
<b>Overall Length</b> Dimensi 体积	299mm (11-3/4")
<b>Net Weight</b> Berat Bersih 净重	2.1kg (4.6lbs)
<b>Power Supply Cord</b> Kabel Wayar 电源线	2.5m (8.2ft)



Cordless  
Tanpa Kord 无绳式

LED Flashlight  
Lampu Suhu LED  
LED照明灯

Vacuum Cleaner  
Pembersih Vakuum  
吸尘器

Drilling / Fastening  
Cairul / Pengisar  
钻孔 / 紧固

Impact Drilling / Demolition  
Cairul / Pengisar  
石工钻孔 / 拆毁动工

Cutting  
Pemotong  
切割

Grinding / Sanding  
Pengisar / Piskah  
研磨 / 砂磨

Sanding  
Gergaji  
锯切

Planing / Routing  
Pengisar / Tanggam  
刨削 / 雕刻

Others  
Lain-lain  
其他

Outdoor Power Equipment  
Alatan Kuasa Luar  
园林户外

**Makita**  
MAKITA

# GRINDING | SANDING

## GA4530 115mm (4-1/2")

459 W

### Angle Grinder Pengisar Sudut 角向磨光机



#### Slide Switch

Suis Gelangsar 滑动开关

- **Small diameter barrel grip for added comfort**  
Genggaman barrel diameter kecil meningkatkan keselesaan  
小直径桶形手柄，增加手握舒适度



**Standard Equipment:** Depressed Center Wheel (A-80640), Side Grip, Wheel Cover, Lock Nut Wrench



<b>Continuous Rating Input</b> Input Kuasa Berterusan 额定输入功率	720W
<b>Wheel Diameter</b> Diameter Roda 轮片直径	115mm (4-1/2")
<b>No Load Speed (RPM)</b> Kelajuan Tanpa Beban 回转数	11,000
<b>Dimensions (L x W x H)</b> Dimensi 体积	266x128x103mm (10-1/2"x5"x4-1/16")
<b>Net Weight</b> Berat Bersih 净重	1.89 - 2.23kg (4.17 - 4.91lbs)
<b>Power Supply Cord</b> Kabel Wayar 电源线	2.5m (8.2ft)

## GA4530R 115mm (4-1/2")

459 W

### Angle Grinder Pengisar Sudut 角向磨光机



#### Slide Switch

Suis Gelangsar 滑动开关

- **Anti-restart function prevents accidental start-up**  
Fungsi anti-restart menghalang penghidupan yang tidak disengajakan  
防重启功能可防止意外启动



**Standard Equipment:** Depressed Center Wheel (A-80640), Side Grip, Wheel Cover, Lock Nut Wrench



<b>Continuous Rating Input</b> Input Kuasa Berterusan 额定输入功率	720W
<b>Wheel Diameter</b> Diameter Roda 轮片直径	115mm (4-1/2")
<b>No Load Speed (RPM)</b> Kelajuan Tanpa Beban 回转数	11,000
<b>Dimensions (L x W x H)</b> Dimensi 体积	266x130x108mm (10-1/2"x5-1/2"x4-1/4")
<b>Net Weight</b> Berat Bersih 净重	1.88 - 2.22kg (4.14 - 4.89lbs)
<b>Power Supply Cord</b> Kabel Wayar 电源线	2.5m (8.2ft)

## 9557HNG / NBG 115mm (4-1/2")

325 W

### Angle Grinder Pengisar Sudut 角向磨光机



#### Slide Switch

Suis Gelangsar 滑动开关

- **Powerful 840W motor**  
Motor berkuasa 840W  
强力840W马达



**Standard Equipment:** Depressed Center Wheel, Side Grip, Wheel Cover, Lock Nut Wrench



<b>Continuous Rating Input</b> Input Kuasa Berterusan 额定输入功率	840W
<b>Wheel Diameter</b> Diameter Roda 轮片直径	115mm (4-1/2")
<b>No Load Speed (RPM)</b> Kelajuan Tanpa Beban 回转数	11,000
<b>Dimensions (L x W x H)</b> Dimensi 体积	271x129x106mm (10-5/8"x5-1/8"x4-3/16")
<b>Net Weight</b> Berat Bersih 净重	1.7 - 2.2kg (3.8 - 4.8lbs)
<b>Power Supply Cord</b> Kabel Wayar 电源线	2.5m (8.2ft)

## 9557HPG 115mm (4-1/2")

325 W

### Angle Grinder Pengisar Sudut 角向磨光机



#### Paddle Switch

Suis Pemacu 扳机开关

- **Large Flush-Mount Paddle Switch for Comfortable Operation**  
Suis Flush-mount mudah digunakan  
大型平装式扳机开关易于操作



**Standard Equipment:** Depressed Center Wheel, Side Grip, Wheel Cover, Lock Nut Wrench



<b>Continuous Rating Input</b> Input Kuasa Berterusan 额定输入功率	840W
<b>Wheel Diameter</b> Diameter Roda 轮片直径	115mm (4-1/2")
<b>No Load Speed (RPM)</b> Kelajuan Tanpa Beban 回转数	11,000
<b>Dimensions (L x W x H)</b> Dimensi 体积	273x129x106mm (10-3/4"x5-1/8"x4-3/16")
<b>Net Weight</b> Berat Bersih 净重	1.8 - 2.2kg (3.9 - 4.8lbs)
<b>Power Supply Cord</b> Kabel Wayar 电源线	2.5m (8.2ft)

## GA4540R 115mm (4-1/2")

325 W

### Angle Grinder Pengisar Sudut 角向磨光机



#### Slide Switch

Suis Gelangsar 滑动开关

- **Super Joint System II developed for effective vibration absorption**  
SJS generasi kedua berkesan untuk menyerap getaran  
第二代 SJS 有效抑制震动



**Standard Equipment:** Depressed Center Wheel (A-80640), Side Grip, Wheel Cover, Lock Nut Wrench



<b>Continuous Rating Input</b> Input Kuasa Berterusan 额定输入功率	1,100W
<b>Wheel Diameter</b> Diameter Roda 轮片直径	115mm (4-1/2")
<b>No Load Speed (RPM)</b> Kelajuan Tanpa Beban 回转数	11,000
<b>Dimensions (L x W x H)</b> Dimensi 体积	303x130x116mm (11-7/8"x5-1/8"x4-9/16")
<b>Net Weight</b> Berat Bersih 净重	2.4 - 2.8kg (5.4 - 6.1lbs)
<b>Power Supply Cord</b> Kabel Wayar 电源线	2.5m (8.2ft)

# GRINDING | SANDING

## GA4540 115mm (4-1/2")

325

### Angle Grinder Pengisar Sudut 角向磨光机



#### Slide Switch

Suis Gelangsar 滑动开关

- Super Joint System II developed for effective vibration absorption  
SJS generasi kedua berkesan untuk menyerap getaran  
第二代 SJS 有效抑止震动



**Standard Equipment:** Depressed Center Wheel (A-80640), Side Grip, Wheel Cover, Lock Nut Wrench



<b>Continuous Rating Input</b> Input Kuasa Berterusan 额定输入功率	1,100W
<b>Wheel Diameter</b> Diameter Roda 轮片直径	115mm (4-1/2")
<b>No Load Speed (RPM)</b> Kelajuan Tanpa Beban 回转数	11,000
<b>Dimensions (L x W x H)</b> Dimensi 体积	303x130x116mm (11-7/8"x5-1/8"x4-9/16")
<b>Net Weight</b> Berat Bersih 净重	2.3 - 2.7kg (5.2 - 5.9lbs)
<b>Power Supply Cord</b> Kabel Wayar 电源线	2.5m (8.2ft)

## GA4541C 115mm (4-1/2")

318

### Angle Grinder Pengisar Sudut 角向磨光机



#### Slide Switch

Suis Gelangsar 滑动开关

- Super Joint System II developed for effective vibration absorption  
SJS generasi kedua berkesan untuk menyerap getaran  
第二代 SJS 有效抑止震动



**Standard Equipment:** Depressed Center Wheel (D-18459), Side Grip, Wheel Cover, Lock Nut Wrench



<b>Continuous Rating Input</b> Input Kuasa Berterusan 额定输入功率	1,400W
<b>Wheel Diameter</b> Diameter Roda 轮片直径	115mm (4-1/2")
<b>No Load Speed (RPM)</b> Kelajuan Tanpa Beban 回转数	2,800-11,000
<b>Dimensions (L x W x H)</b> Dimensi 体积	325x130x121mm (12-3/4"x5-1/8"x4-3/4")
<b>Net Weight</b> Berat Bersih 净重	2.7 - 3.0kg (5.9 - 6.7lbs)
<b>Power Supply Cord</b> Kabel Wayar 电源线	2.5m (8.2ft)



## GA5030 125mm (5")

459

### Angle Grinder Pengisar Sudut 角向磨光机



#### Slide Switch

Suis Gelangsar 滑动开关

- Machined bevel gears provide up to 2x longer service life  
Gear bevel machined memajukan hayat penggunaan 2x lebih lama  
加工锥齿轮延长了长达 2x 的使用寿命



**Standard Equipment:** Depressed Center Wheel (A-80656), Side Grip, Wheel Cover, Lock Nut Wrench



<b>Continuous Rating Input</b> Input Kuasa Berterusan 额定输入功率	720W
<b>Wheel Diameter</b> Diameter Roda 轮片直径	125mm (5")
<b>No Load Speed (RPM)</b> Kelajuan Tanpa Beban 回转数	11,000
<b>Dimensions (L x W x H)</b> Dimensi 体积	266x138x103mm (10-1/2"x5-7/16"x4-1/16")
<b>Net Weight</b> Berat Bersih 净重	1.92 - 3.07kg (4.23 - 6.77lbs)
<b>Power Supply Cord</b> Kabel Wayar 电源线	2.5m (8.2ft)

## GA5030R 125mm (5")

459

### Angle Grinder Pengisar Sudut 角向磨光机



#### Slide Switch

Suis Gelangsar 滑动开关

- Anti-restart function prevents accidental start-up  
Fungsi anti-restart menghalang penghidupan yang tidak disengajakan  
防重启功能可防止意外启动



**Standard Equipment:** Depressed Center Wheel (A-80656), Side Grip, Wheel Cover, Lock Nut Wrench



<b>Continuous Rating Input</b> Input Kuasa Berterusan 额定输入功率	720W
<b>Wheel Diameter</b> Diameter Roda 轮片直径	125mm (5")
<b>No Load Speed (RPM)</b> Kelajuan Tanpa Beban 回转数	11,000
<b>Dimensions (L x W x H)</b> Dimensi 体积	266x140x108mm (10-1/2"x5-1/2"x4-1/4")
<b>Net Weight</b> Berat Bersih 净重	1.91 - 3.06kg (4.21 - 6.75lbs)
<b>Power Supply Cord</b> Kabel Wayar 电源线	2.5m (8.2ft)

Cordless  
Tangkas Akad 充电式LED Flashlight  
Lampu Suhu LED  
LED 照明灯Vacuum Cleaner  
Pembersih Vakuum  
吸尘器Drilling / Fastening  
Cairul / Pengisar  
钻孔 / 紧固Impact Drilling / Demolition  
Cairul / Pengisar  
石工钻孔 / 摧毁动工Cutting  
Pemotong  
切割Grinding / Sanding  
Pengisar / Poles  
研磨 / 打磨Sawing  
Gergaji  
锯切Planing / Routing  
Penghalus / Tunggam  
刨削 / 雕刻Others  
Lain-lain  
其他Outdoor Power Equipment  
Alatan Kuasa Luar  
户外动力工具Makita  
MAKITA

# GRINDING | SANDING

Cordless  
Tangki Roda Baterai

LED Flashlight  
Lampu Suhu LED  
LED 照明灯

Vacuum Cleaner  
Pembersih Vakum  
吸尘器

Drilling | Fastening  
Gardu | Pengikat  
钻孔 | 紧固

Impact Drilling | Demolition  
Gardu | Perusak  
冲击钻孔 | 拆除加工

Cutting  
Pemotong  
切割

Grinding | Sanding  
Pengisar | Pasir  
打磨 | 磨光

Sawing  
Gergaji  
锯切

Planing | Routing  
Pengaliran | Tanggapan  
刨削 | 雕刻

Others  
Lain-lain  
其他

Outdoor Power Equipment  
Alat-alat Luar  
园林-户外

Makita  
MAKITA

## GA5034 125mm (5")

459 W

### Angle Grinder Pengisar Sudut 角向磨光机



#### Paddle Switch Suis Pemicu 扳机开关

- **Small Diameter Barrel Grip**  
Genggamannya Barel Diameter Kecil  
小直径握把



**Standard Equipment:** Depressed Center Wheel (A-80656), Side Grip, Wheel Cover, Lock Nut Wrench



<b>Continuous Rating Input</b> Input Kuasa Berterusan 额定输入功率	720W
<b>Wheel Diameter</b> Diameter Roda 轮片直径	125mm (5")
<b>No Load Speed (RPM)</b> Kelajuan Tanpa Beban 回转数	11,000
<b>Dimensions (L x W x H)</b> Dimensi 体积	265x139x103mm (10-3/8"x5-1/2"x4-1/16")
<b>Net Weight</b> Berat Bersih 净重	2.00 - 3.15kg (4.41 - 6.94lbs)
<b>Power Supply Cord</b> Kabel Wayar 电源线	2.5m (8.2ft)

## 9558HNG / NBG 125mm (5")

325 W

### Angle Grinder Pengisar Sudut 角向磨光机



#### Slide Switch Suis Gelasar 滑动开关

- **Slide switch with lock-on for continuous use**  
Suis gelangsar dengan fungsi mengunci untuk kegunaan berterusan  
备有锁定功能的滑动按钮可连续无间断的使用



**Standard Equipment:** Depressed Center Wheel, Side Grip, Wheel Cover, Lock Nut Wrench



<b>Continuous Rating Input</b> Input Kuasa Berterusan 额定输入功率	840W
<b>Wheel Diameter</b> Diameter Roda 轮片直径	125mm (5")
<b>No Load Speed (RPM)</b> Kelajuan Tanpa Beban 回转数	11,000
<b>Dimensions (L x W x H)</b> Dimensi 体积	271x139x106mm (10-5/8"x5-1/2"x4-3/16")
<b>Net Weight</b> Berat Bersih 净重	1.7 - 3.2kg (3.8 - 6.6lbs)
<b>Power Supply Cord</b> Kabel Wayar 电源线	2.5m (8.2ft)

## 9558HPG 125mm (5")

325 W

### Angle Grinder Pengisar Sudut 角向磨光机



#### Paddle Switch Suis Pemicu 扳机开关

- **Large Flush-Mount Paddle Switch for Comfortable Operation**  
Suis Flush-mount mudah digunakan  
大型平装式扳机开关易于操作



**Standard Equipment:** Depressed Center Wheel, Side Grip, Wheel Cover, Lock Nut Wrench



<b>Continuous Rating Input</b> Input Kuasa Berterusan 额定输入功率	840W
<b>Wheel Diameter</b> Diameter Roda 轮片直径	125mm (5")
<b>No Load Speed (RPM)</b> Kelajuan Tanpa Beban 回转数	11,000
<b>Dimensions (L x W x H)</b> Dimensi 体积	273x139x106mm (10-3/4"x5-1/2"x4-3/16")
<b>Net Weight</b> Berat Bersih 净重	1.8 - 3.0kg (3.9 - 6.7lbs)
<b>Power Supply Cord</b> Kabel Wayar 电源线	2.5m (8.2ft)

## GA5020 125mm (5")

303 W

### Angle Grinder Pengisar Sudut 角向磨光机



#### Trigger Switch Suis Pemicu 扳机开关

- **SJS Mechanical Clutch System Helps Prevent Motor and Gear Damage**  
Sistem SJS mencegah kerosakan pada motor dan gear  
SJS 系统有助于防止马达和齿轮损坏



**Standard Equipment:** Depressed Center Wheel (A-80656), Side Grip, Wheel Cover, Lock Nut Wrench



<b>Continuous Rating Input</b> Input Kuasa Berterusan 额定输入功率	1,050W
<b>Wheel Diameter</b> Diameter Roda 轮片直径	125mm (5")
<b>No Load Speed (RPM)</b> Kelajuan Tanpa Beban 回转数	12,000
<b>Dimensions (L x W x H)</b> Dimensi 体积	356x139x120mm (14"x5-1/2"x4-3/4")
<b>Net Weight</b> Berat Bersih 净重	2.7 - 3.9kg (6.0 - 8.6lbs)
<b>Power Supply Cord</b> Kabel Wayar 电源线	2.5m (8.2ft)

## GA5010 125mm (5")

303 W

### Angle Grinder Pengisar Sudut 角向磨光机



#### Trigger Switch Suis Pemicu 扳机开关

- **Powerful 1,050W motor**  
Motor berkuasa 1,050W  
强力1,050W马达



**Standard Equipment:** Depressed Center Wheel (A-80656), Side Grip, Wheel Cover, Lock Nut Wrench



<b>Continuous Rating Input</b> Input Kuasa Berterusan 额定输入功率	1,050W
<b>Wheel Diameter</b> Diameter Roda 轮片直径	125mm (5")
<b>No Load Speed (RPM)</b> Kelajuan Tanpa Beban 回转数	12,000
<b>Dimensions (L x W x H)</b> Dimensi 体积	356x139x112mm (14"x5-1/2"x4-3/8")
<b>Net Weight</b> Berat Bersih 净重	2.6 - 3.8kg (5.8 - 8.4lbs)
<b>Power Supply Cord</b> Kabel Wayar 电源线	2.5m (8.2ft)

# GRINDING | SANDING

## GA5040 125mm (5") 325

**Angle Grinder**  
Pengisar Sudut  
角向磨光机



**Slide Switch**  
Suis Gelangsar 滑动开关



- **Connectable to Makita vacuum cleaner with optional dust collecting wheel guard**  
Boleh bersambung dengan pembersih vakum Makita dengan alat pilihan pengumpul debu  
可选附件轮状集尘罩以连接 Makita 吸尘器

**Standard Equipment:** Depressed Center Wheel, Side Grip, Wheel Cover, Lock Nut Wrench



<b>Continuous Rating Input</b> Input Kuasa Berterusan 额定输入功率	1,100W
<b>Wheel Diameter</b> Diameter Roda 轮片直径	125mm (5")
<b>No Load Speed (RPM)</b> Kelajuan Tanpa Beban 回转数	11,000
<b>Dimensions (L x W x H)</b> Dimensi 体积	303x140x116mm (11-7/8"x5-1/2"x4-9/16")
<b>Net Weight</b> Berat Bersih 净重	2.4 - 3.5kg (5.2 - 7.8lbs)
<b>Power Supply Cord</b> Kabel Wayar 电源线	2.5m (8.2ft)

## GA5041C 125mm (5") 318

**Angle Grinder**  
Pengisar Sudut  
角向磨光机



**Slide Switch**  
Suis Gelangsar 滑动开关



- **Super Joint System II developed for effective vibration absorption**  
SJS generasi kedua berkesan untuk menyerap getaran  
第二代 SJS 有效抑止震动

**Standard Equipment:** Depressed Center Wheel, Side Grip, Wheel Cover, Lock Nut Wrench



<b>Continuous Rating Input</b> Input Kuasa Berterusan 额定输入功率	1,400W
<b>Wheel Diameter</b> Diameter Roda 轮片直径	125mm (5")
<b>No Load Speed (RPM)</b> Kelajuan Tanpa Beban 回转数	2,800-11,000
<b>Dimensions (L x W x H)</b> Dimensi 体积	325x140x121mm (12-3/4"x5-1/2"x4-3/4")
<b>Net Weight</b> Berat Bersih 净重	2.7 - 3.8kg (5.9 - 8.4lbs)
<b>Power Supply Cord</b> Kabel Wayar 电源线	2.5m (8.2ft)

## 9565CR / PC 125mm (5") 318

**Angle Grinder**  
Pengisar Sudut  
角向磨光机



**9565CR**  
**Slide Switch**  
Suis Gelangsar 滑动开关



- **SJS Mechanical Clutch System Helps Prevent Motor and Gear Damage**  
Sistem SJS mencegah kerosakan pada motor dan gear  
SJS 系统有助于防止马达和齿轮损坏

**Standard Equipment:**  
9565CR: Depressed Center Wheel (B-56390), Side Grip, Wheel Cover, Lock Nut Wrench  
9565PC: Side Grip, Wheel Cover, Lock Nut Wrench



<b>Continuous Rating Input</b> Input Kuasa Berterusan 额定输入功率	1,400W
<b>Wheel Diameter</b> Diameter Roda 轮片直径	125mm (5")
<b>No Load Speed (RPM)</b> Kelajuan Tanpa Beban 回转数	12,000
<b>Dimensions (L x W x H)</b> Dimensi 体积	299x139x103mm <b>9565CR</b> (11-3/4"x5-1/2"x4-1/16") 307x139x103mm <b>9565PC</b> (12-1/8"x5-1/2"x4")
<b>Net Weight</b> Berat Bersih 净重	2.4 - 3.5kg (5.2 - 7.7lbs)
<b>Power Supply Cord</b> Kabel Wayar 电源线	2.5m (8.2ft)

**Recommended Accessories**  
Grinding Wheel for Heavy Industries



## GA6010 150mm (6") 303

**Angle Grinder**  
Pengisar Sudut  
角向磨光机



**Trigger Switch**  
Suis Pemacu 扳机开关



- **Powerful 1,050W motor**  
Motor berkuasa 1,050W  
强力1,050W马达

**Standard Equipment:** Depressed Center Wheel (A-80846), Side Grip, Wheel Cover, Lock Nut Wrench



<b>Continuous Rating Input</b> Input Kuasa Berterusan 额定输入功率	1,050W
<b>Wheel Diameter</b> Diameter Roda 轮片直径	150mm (6")
<b>No Load Speed (RPM)</b> Kelajuan Tanpa Beban 回转数	10,000
<b>Dimensions (L x W x H)</b> Dimensi 体积	356x169x112mm (14"x6-5/8"x4-3/8")
<b>Net Weight</b> Berat Bersih 净重	2.7 - 3.1kg (5.9 - 6.9lbs)
<b>Power Supply Cord</b> Kabel Wayar 电源线	2.5m (8.2ft)

Cordless  
Tanggap Kord 无绳式

LED Flashlight  
Lampu Cahaya LED  
LED照明灯

Vacuum Cleaner  
Pembersih Vakum  
吸尘器

Drilling / Fastening  
Cairul / Pasang  
钻孔 / 紧固

Impact Drilling / Demolition  
Cairul / Pasang  
石工钻孔 / 摧毁施工

Cutting  
Pemotong  
切割

Grinding / Sanding  
Pangkas / Poles  
研磨 / 打磨

Sanding  
Giling  
打磨

Planing / Routing  
Perataan / Tonggam  
刨削 / 雕刻

Others  
Lain-lain  
其他

Outdoor Power Equipment  
Alatan Kuat Luar  
户外动力工具

**Makita**  
工具

# GRINDING | SANDING

Cordless  
Tangas Tanpa Kabel

LED Flashlight  
Lampu Sinar LED  
LED 照灯

Vacuum Cleaner  
Pembersih Vakum  
吸尘器

Drilling | Fastening  
Gardu | Pengikat  
钻孔 | 紧固

Impact Drilling | Demolition  
Gardu | Perusakan  
冲击钻孔 | 拆除加工

Cutting  
Pemotong  
切割

Grinding | Sanding  
Pengisar | Poles  
磨削 | 打磨

Sawing  
Gergaji  
锯切

Planing | Routing  
Pengaliran | Tanggapan  
刨削 | 雕刻

Others  
Lain-lain  
其他

Outdoor Power Equipment  
Alat-alat Tenaga Luar  
园机-户外

Makita  
MAKITA

## GA6040 150mm (6")

325 W

### Angle Grinder Pengisar Sudut 角向磨光机



#### Slide Switch Suis Gelangsar 滑动开关

- Super Joint System II developed for effective vibration absorption  
SJS generasi kedua berkesan untuk menyerap getaran  
第二代 SJS 有效防止震动



Standard Equipment: Depressed Center Wheel (A-80846), Side Grip, Wheel Cover, Lock Nut Wrench



Continuous Rating Input Input Kuasa Berterusan 额定输入功率	1,100W
Wheel Diameter Diameter Roda 轮片直径	150mm (6")
No Load Speed (RPM) Kelajuan Tanpa Beban 回转数	9,000
Dimensions (L x W x H) Dimensi 体积	303x171x116mm (11-7/8"x6-3/4"x4-9/16")
Net Weight Berat Bersih 净重	2.4 - 2.8kg (5.3 - 6.2lbs)
Power Supply Cord Kabel Wayar 电源线	2.5m (8.2ft)

## GA6020C 150mm (6")

253 W

### Angle Grinder Pengisar Sudut 角向磨光机



#### Trigger Switch Suis Pemicu 扳机开关

- Electric current limiter protects motor from overload  
Pembatasan arus elektrik melindungi motor dari kelebihan beban  
电流限制器保护马达免超负荷



Standard Equipment: Depressed Center Wheel (A-80846), Side Grip, Wheel Cover, Lock Nut Wrench



Continuous Rating Input Input Kuasa Berterusan 额定输入功率	1,450W
Wheel Diameter Diameter Roda 轮片直径	150mm (6")
No Load Speed (RPM) Kelajuan Tanpa Beban 回转数	9,000
Dimensions (L x W x H) Dimensi 体积	390x169x120mm (15-3/8"x6-5/8"x4-3/4")
Net Weight Berat Bersih 净重	3.0 - 3.5kg (6.7 - 7.6lbs)
Power Supply Cord Kabel Wayar 电源线	2.5m (8.2ft)



## GA7050 180mm (7")

204 W

### Angle Grinder Pengisar Sudut 角向磨光机



#### Trigger Switch Suis Pemicu 扳机开关

- Most compact in its class  
Paling padat dalam kelasnya  
在同类中最紧凑



Standard Equipment: Side Grip, Wheel Cover, Lock Nut Wrench



Continuous Rating Input Input Kuasa Berterusan 额定输入功率	2,000W
Wheel Diameter Diameter Roda 轮片直径	180mm (7")
No Load Speed (RPM) Kelajuan Tanpa Beban 回转数	8,500
Dimensions (L x W x H) Dimensi 体积	432x200x132mm (17"x7-7/8"x5-3/16")
Net Weight Berat Bersih 净重	3.98 - 5.00kg (8.8 - 11.0lbs)
Power Supply Cord Kabel Wayar 电源线	2.5m (8.2ft)

## GA7063R 180mm (7")

218 W

### Angle Grinder Pengisar Sudut 角向磨光机

#### Trigger Switch Suis Pemicu 扳机开关

- D-Handle protects operator's hand from materials  
Pemegang D melindungi tangan pengguna dari bahan  
D型把手保护使用者的手远离物料



Standard Equipment: Side Grip, Wheel Cover, Lock Nut Wrench



Continuous rating input Panjang Strok 冲程长度	2,200W
Wheel Diameter Kelajuan Strok 冲程速度	180mm (7")
No Load Speed (RPM) Kapasiti 能力	8,500
Dimensions (L x W x H) Dimensi 体积	450x200x145mm (17-3/4"x7-7/8"x5-3/4")
Net weight Berat Bersih 净重	5.70 - 6.21kg (12.6 - 13.7lbs)
Power supply cord	2.5m (8.2ft.)



# GRINDING | SANDING

## GA7062 180mm (7") 218

**Angle Grinder**  
Pengisar Sudut  
角向磨光机

**Trigger Switch**  
Suis Pemicu 扳机开关

- Developed for heavy duty applications such as **foundry grinding**  
Sesuai untuk aplikasi tugas berat  
适合重型应用，如铸造磨削加工



Standard Equipment: Side Grip, Wheel Cover, Lock Nut Wrench



<b>Continuous Rating Input</b> Input Kuasa Berterusan 额定输入功率	2,200W
<b>Wheel Diameter</b> Diameter Roda 轮片直径	180mm (7")
<b>No Load Speed (RPM)</b> Kelajuan Tanpa Beban 回转数	8,500
<b>Dimensions (L x W x H)</b> Dimensi 体积	450x200x144mm (17-3/4"x7-7/8"x5-5/8")
<b>Net Weight</b> Berat Bersih 净重	5.51 - 6.02kg (12.2 - 13.3lbs)
<b>Power Supply Cord</b> Kabel Wayar 电源线	2.5m (8.2ft.)

## GA7061R 180mm (7") 218

**Angle Grinder**  
Pengisar Sudut  
角向磨光机

**Trigger Switch**  
Suis Pemicu 扳机开关

- Developed for heavy duty applications such as **foundry grinding**  
Ringan untuk mengurangkan keletihan, meningkatkan produksi dengan berkesan  
轻量不易引起疲劳，有效的增加工作量



Standard Equipment: Side Grip, Wheel Cover, Lock Nut Wrench



<b>Continuous Rating Input</b> Input Kuasa Berterusan 额定输入功率	2,200W
<b>Wheel Diameter</b> Diameter Roda 轮片直径	180mm (7")
<b>No Load Speed (RPM)</b> Kelajuan Tanpa Beban 回转数	8,500
<b>Dimensions (L x W x H)</b> Dimensi 体积	450x200x145mm (17-3/4"x7-7/8"x5-3/4")
<b>Net Weight</b> Berat Bersih 净重	5.57 - 6.08kg (12.3 - 13.4lbs)
<b>Power Supply Cord</b> Kabel Wayar 电源线	2.5m (8.2ft)

## GA7060R 180mm (7") 218

**Angle Grinder**  
Pengisar Sudut  
角向磨光机

**Trigger Switch**  
Suis Pemicu 扳机开关

- Developed for heavy duty applications such as **foundry grinding**  
Sesuai untuk aplikasi tugas berat  
适合重型应用，如铸造磨削加工



Standard Equipment: Side Grip, Wheel Cover, Lock Nut Wrench



<b>Continuous Rating Input</b> Input Kuasa Berterusan 额定输入功率	2,200W
<b>Wheel Diameter</b> Diameter Roda 轮片直径	180mm (7")
<b>No Load Speed (RPM)</b> Kelajuan Tanpa Beban 回转数	8,500
<b>Dimensions (L x W x H)</b> Dimensi 体积	450x200x144mm (17-3/4"x7-7/8"x5-5/8")
<b>Net Weight</b> Berat Bersih 净重	5.42 - 5.93kg (12 - 13.1lbs)
<b>Power Supply Cord</b> Kabel Wayar 电源线	2.5m (8.2ft)

## GA7060 180mm (7") 218

**Angle Grinder**  
Pengisar Sudut  
角向磨光机

**Trigger Switch**  
Suis Pemicu 扳机开关

- **Motor more durable for heavy duty applications**  
Motor lebih tahan lama untuk aplikasi tugas berat  
马达更耐用



Standard Equipment: Side Grip, Wheel Cover, Lock Nut Wrench



<b>Continuous Rating Input</b> Input Kuasa Berterusan 额定输入功率	2,200W
<b>Wheel Diameter</b> Diameter Roda 轮片直径	180mm (7")
<b>No Load Speed (RPM)</b> Kelajuan Tanpa Beban 回转数	8,500
<b>Dimensions (L x W x H)</b> Dimensi 体积	450x200x144mm (17-3/4"x7-7/8"x5-5/8")
<b>Net Weight</b> Berat Bersih 净重	5.38 - 5.89kg (11.9 - 13lbs)
<b>Power Supply Cord</b> Kabel Wayar 电源线	2.5m (8.2ft)

## GA7020 180mm (7") 204

**Angle Grinder**  
Pengisar Sudut  
角向磨光机

**Trigger Switch**  
Suis Pemicu 扳机开关

- **Powerful 2,200W Motor for Faster Material Removal**  
Motor berkuasa 2,200W untuk pengisaran yang lebih cepat  
功率强大的 2,200W 马达提供更快的研磨



Standard Equipment: Side Grip, Wheel Cover, Lock Nut Wrench



<b>Continuous Rating Input</b> Input Kuasa Berterusan 额定输入功率	2,200W
<b>Wheel Diameter</b> Diameter Roda 轮片直径	180mm (7")
<b>No Load Speed (RPM)</b> Kelajuan Tanpa Beban 回转数	8,500
<b>Dimensions (L x W x H)</b> Dimensi 体积	473x200x140mm (18-5/8"x7-7/8"x5-1/2")
<b>Net Weight</b> Berat Bersih 净重	5.56 - 6.06kg (12.26 - 13.36lbs)
<b>Power Supply Cord</b> Kabel Wayar 电源线	2.5m (8.2ft)

Cordless  
Tanpa Kord 无绳式

LED Flashlight  
Lampu Suluh LED  
LED照明灯

Vacuum Cleaner  
Pembersih Vakuum  
吸尘器

Drilling / Fastening  
Cairul / Pengikat  
钻孔 / 紧固

Impact Drilling / Demolition  
Cairul / Pembuat  
石工钻孔 / 拆毁施工

Cutting  
Pemotong  
切割

Grinding / Sanding  
Pangkas / Poles  
研磨 / 砂磨

Sawing  
Gergaji  
锯切

Planing / Routing  
Pegyalan / Tunggam  
刨削 / 雕刻

Others  
Lain-lain  
其他

Outdoor Power Equipment  
Alatan Kuasa Luar  
户外动力工具



# GRINDING | SANDING

## GA7040R 180mm (7")

204 W

### Angle Grinder Pengisar Sudut 角向磨光机



#### Trigger Switch Suis Pemicu 扳机开关

- Superior heavy duty motor with outstanding durability  
Motor tugas berat unggul dengan ketahanan yang luar biasa  
耐用性卓越的马达



Standard Equipment: Side Grip, Wheel Cover, Lock Nut Wrench



<b>Continuous Rating Input</b> Input Kuasa Berterusan 额定输入功率	2,600W
<b>Wheel Diameter</b> Diameter Roda 轮片直径	180mm (7")
<b>No Load Speed (RPM)</b> Kelajuan Tanpa Beban 回转速数	8,500
<b>Dimensions (L x W x H)</b> Dimensi 体积	503x200x140mm (19-3/4"x7-7/8"x5-1/2")
<b>Net Weight</b> Berat Bersih 净重	6.48 - 6.98kg (14.3 - 15.4lbs)
<b>Power Supply Cord</b> Kabel Wayar 电源线	2.5m (8.2ft)



## GA9050 230mm (9")

204 W

### Angle Grinder Pengisar Sudut 角向磨光机



#### Trigger Switch Suis Pemicu 扳机开关

- Compact gear housing increases maximum cutting depth by 4mm  
Kotak gear padat untuk meningkatkan kedalaman pemotongan maksimum kepada 4mm  
紧凑的齿轮箱增加最大切割深度至4mm



Standard Equipment: Side Grip, Wheel Cover, Lock Nut Wrench



<b>Continuous Rating Input</b> Input Kuasa Berterusan 额定输入功率	2,000W
<b>Wheel Diameter</b> Diameter Roda 轮片直径	230mm (9")
<b>No Load Speed (RPM)</b> Kelajuan Tanpa Beban 回转速数	6,600
<b>Dimensions (L x W x H)</b> Dimensi 体积	432x250x132mm (17"x9-7/8"x5-3/16")
<b>Net Weight</b> Berat Bersih 净重	4.64 - 6.94kg (10.2 - 15.3lbs)
<b>Power Supply Cord</b> Kabel Wayar 电源线	2.5m (8.2ft)

## GA9061R 230mm (9")

218 W

### Angle Grinder Pengisar Sudut 角向磨光机



#### Trigger Switch Suis Pemicu 扳机开关

- Motor more durable for heavy duty applications  
Motor lebih tahan lama untuk aplikasi tugas berat  
马达更耐用



Standard Equipment: Side Grip, Wheel Cover, Lock Nut Wrench



<b>Continuous Rating Input</b> Input Kuasa Berterusan 额定输入功率	2,200W
<b>Wheel Diameter</b> Diameter Roda 轮片直径	230mm (9")
<b>No Load Speed (RPM)</b> Kelajuan Tanpa Beban 回转速数	6,600
<b>Dimensions (L x W x H)</b> Dimensi 体积	450x250x145mm (17-3/4"x9-7/8"x5-3/4")
<b>Net Weight</b> Berat Bersih 净重	5.68 - 8.04kg (12.5 - 17.7lbs)
<b>Power Supply Cord</b> Kabel Wayar 电源线	2.5m (8.2ft)

## GA9060R 230mm (9")

218 W

### Angle Grinder Pengisar Sudut 角向磨光机



#### Trigger Switch Suis Pemicu 扳机开关

- Powerful 2,200W motor  
Motor berkuasa 2,200W  
强力2,200W马达



Standard Equipment: Side Grip, Wheel Cover, Lock Nut Wrench



<b>Continuous Rating Input</b> Input Kuasa Berterusan 额定输入功率	2,200W
<b>Wheel Diameter</b> Diameter Roda 轮片直径	230mm (9")
<b>No Load Speed (RPM)</b> Kelajuan Tanpa Beban 回转速数	6,600
<b>Dimensions (L x W x H)</b> Dimensi 体积	450x250x144mm (17-3/4"x9-7/8"x5-5/8")
<b>Net Weight</b> Berat Bersih 净重	5.52 - 7.88kg (12.8 - 17.4lbs)
<b>Power Supply Cord</b> Kabel Wayar 电源线	2.5m (8.2ft)

Cordless  
Tanggap Hood 角磨机

LED Flashlight  
Lampu Suluh LED  
LED 照明灯

Vacuum Cleaner  
Pembersih Vakuum  
吸尘器

Drilling | Fastening  
Ganda | Pengikat  
钻孔 | 紧固

Impact Drilling | Demolition  
Ganda | Pemusnah  
冲击钻孔 | 拆除加工

Cutting  
Pemotong  
切割

Grinding | Sanding  
Pengisar | Pasir  
打磨 | 打磨

Sawing  
Ganda  
锯切

Planing | Routing  
Pengaliran | Tanggapan  
刨削 | 雕刻

Others  
Lain-lain  
其他

Outdoor Power Equipment  
Alatan Kuasa Luar  
园机-户外

Makita  
INT

# GRINDING | SANDING

## GA9060 230mm (9") 218 W

**Angle Grinder**  
Pengisar Sudut  
角向磨光机



**Trigger Switch**  
Suis Pemacu 扳机开关

- **Motor more durable for heavy duty applications**  
Motor lebih tahan lama untuk aplikasi tugas berat  
马达更耐用



Standard Equipment: Side Grip, Wheel Cover, Lock Nut Wrench



<b>Continuous Rating Input</b> Input Kuasa Berterusan 额定输入功率	2,200W
<b>Wheel Diameter</b> Diameter Roda 轮片直径	230mm (9")
<b>No Load Speed (RPM)</b> Kelajuan Tanpa Beban 回转数	6,600
<b>Dimensions (L x W x H)</b> Dimensi 体积	450x250x144mm (17-3/4"x9-7/8"x5-5/8")
<b>Net Weight</b> Berat Bersih 净重	5.50 - 7.86kg (12.1 - 17.3lbs)
<b>Power Supply Cord</b> Kabel Wayar 电源线	2.5m (8.2ft)

## GA9020 230mm (9") 204 W

**Angle Grinder**  
Pengisar Sudut  
角向磨光机



**Trigger Switch**  
Suis Pemacu 扳机开关

- **Spiral bevel gears more efficient transfer of energy**  
Gear serong lingkaran untuk pemindahan tenaga yang lebih cekap  
螺旋锥齿轮高效输送能源



Standard Equipment: Side Grip, Wheel Cover, Lock Nut Wrench



<b>Continuous Rating Input</b> Input Kuasa Berterusan 额定输入功率	2,200W
<b>Wheel Diameter</b> Diameter Roda 轮片直径	230mm (9")
<b>No Load Speed (RPM)</b> Kelajuan Tanpa Beban 回转数	6,000
<b>Dimensions (L x W x H)</b> Dimensi 体积	473x249x140mm (18-5/8"x9-3/4"x5-1/2")
<b>Net Weight</b> Berat Bersih 净重	5.76 - 8.05kg (12.7 - 17.8lbs)
<b>Power Supply Cord</b> Kabel Wayar 电源线	2.5m (8.2ft)



## SA5040C 125mm (5") 318 W

**Angle Sander**  
Pengampelas Sudut  
角向抛光机



- **Electronic current limiter prevents motor burnout due to overloading**  
Pengehad arus elektronik mencegah motor dari terbakar yang disebabkan oleh beban lampau  
电子电流限制器可防止超负荷引起的马达烧毁



Standard Equipment: Pad, Side Grip, Head Cover

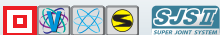

<b>Continuous Rating Input</b> Input Kuasa Berterusan 额定输入功率	1,400W
<b>Wheel Diameter</b> Diameter Roda 轮片直径	125mm (5")
<b>Capacity</b> Kapasiti 能力	Pad : 115mm (4-1/2")
<b>No Load Speed (RPM)</b> Kelajuan Tanpa Beban 回转数	2,000-7,800
<b>Dimensions (L x W x H)</b> Dimensi 体积	315x115x121mm (12-3/8"x4-1/2"x4-3/4")
<b>Net Weight</b> Berat Bersih 净重	2.5 - 3.7kg (5.5 - 8.2lbs)
<b>Power Supply Cord</b> Kabel Wayar 电源线	2.5m (8.2ft)

## PK5001C 125mm (5") 318 W

**Angle Sander**  
Pengampelas Sudut  
角向抛光机



- **Ideal one for effective stone polishing**  
Untuk penggilap batu yang berkesan  
有效的石材抛光



Standard Equipment: Side Grip, Lock Nut Wrench



<b>Continuous Rating Input</b> Input Kuasa Berterusan 额定输入功率	1,400W
<b>Wheel Diameter</b> Diameter Roda 轮片直径	125mm (5")
<b>Capacity</b> Kapasiti 能力	Pad : 115mm (4-1/2")
<b>No Load Speed (RPM)</b> Kelajuan Tanpa Beban 回转数	2,000-6,800
<b>Dimensions (L x W x H)</b> Dimensi 体积	328x80x126mm (12-7/8"x3-1/8"x5")
<b>Net Weight</b> Berat Bersih 净重	2.4 - 2.9kg (5.3 - 6.4lbs)
<b>Power Supply Cord</b> Kabel Wayar 电源线	4.0m (13.1ft)

Cordless  
Tangkas Akad 充电式

LED Flashlight  
Lampu Suhu LED  
LED照明灯

Vacuum Cleaner  
Pembersih Vakuum  
吸尘器

Drilling / Fastening  
Cairul / Pengikat  
钻孔 / 紧固

Impact Drilling / Demolition  
Cairul / Penusuk  
石工钻孔 / 拆毁动工

Cutting  
Pemotong  
切割

Grinding / Sanding  
Penggilap / Poles  
研磨 / 打磨

Sanding  
Gergaji  
锯切

Planing / Routing  
Pengaliran / Tunggam  
刨削 / 雕刻

Others  
Lain-lain  
其他

Outdoor Power Equipment  
Alatan Kuat Luar  
户外动力设备

**makita**  
MAKITA

# GRINDING | SANDING

## GV5010 125mm (5")

64 W

### Disc Sander

Pelicin Piring  
盘式砂光机



- **For faster and easier removal of paint/ rust**  
Untuk penyingkiran cat / karat yang lebih cepat dan mudah  
更快、更容易去除油漆/锈蚀

**Standard Equipment:** Abrasive Disc, Plastic Pad, Side Grip,  
Hex socket head bolt, Washer, Hex Wrench



<b>Continuous Rating Input</b> Input Kuasa Berterusan 额定输入功率	440W
<b>Abrasive Disc Size</b> Saiz Cakera 磨盘尺寸	125mm (5")
<b>Capacity</b> Kapasiti 能力	Pad: 120mm (4-3/4")
<b>No Load Speed (RPM)</b> Kelajuan Tanpa Beban 回转数	4,500
<b>Dimensions (L x W x H)</b> Dimensi 体积	200x74x181mm (7-7/8"x2-15/16"x7-1/8")
<b>Net Weight</b> Berat Bersih 净重	1.2kg (2.6lbs)
<b>Power Supply Cord</b> Kabel Wayar 电源线	2.5m (8.2ft)

## GV6010 150mm (6")

64 W

### Disc Sander

Pelicin Piring  
盘式砂光机



- **Powerful 440W motor for fast material removal**  
Motor berkuasa 440W untuk penyingkiran bahan cepat  
功率强劲的440W马达

**Standard Equipment:** Abrasive Disc, Plastic Pad, Side Grip,  
Hex socket head bolt, Washer, Hex Wrench



<b>Continuous Rating Input</b> Input Kuasa Berterusan 额定输入功率	440W
<b>Abrasive Disc Size</b> Saiz Cakera 磨盘尺寸	150mm (6")
<b>Capacity</b> Kapasiti 能力	Pad: 120mm (4-3/4")
<b>No Load Speed (RPM)</b> Kelajuan Tanpa Beban 回转数	4,500
<b>Dimensions (L x W x H)</b> Dimensi 体积	200x74x181mm (7-7/8"x2-15/16"x7-1/8")
<b>Net Weight</b> Berat Bersih 净重	1.2kg (2.6lbs)
<b>Power Supply Cord</b> Kabel Wayar 电源线	2.5m (8.2ft)

## GV7000C 180mm (7")

303 W

### Disc Sander

Pelicin Piring  
盘式砂光机



- **Motor-over-pad design for better balance and control**  
Reka bentuk motor-over-pad untuk keseimbangan dan kawalan yang lebih baik  
更好的平衡易于控制

**Standard Equipment:** Abrasive Disc, Rubber Pad,  
Lock Nut Wrench, Wrench, Side Grip



<b>Continuous Rating Input</b> Input Kuasa Berterusan 额定输入功率	900W
<b>Abrasive Disc Size</b> Saiz Cakera 磨盘尺寸	180mm (7")
<b>Capacity</b> Kapasiti 能力	Pad: 180mm (7")
<b>No Load Speed (RPM)</b> Kelajuan Tanpa Beban 回转数	2,500-4,700
<b>Overall Length</b> Panjang Keseluruhan 总长度	210mm (8-1/4")
<b>Net Weight</b> Berat Bersih 净重	2.1kg (4.6lbs)
<b>Power Supply Cord</b> Kabel Wayar 电源线	2.5m (8.2ft)

## 9215SB 150mm (6")

100 W

### Disc Sander

Pelicin Piring  
盘式砂光机



- **Powerful motor in well-balanced body for fast and steady sanding**  
Motor berkuasa dengan badan yang seimbang  
强劲的马达平衡良好及机身

**Standard Equipment:** Rubber Pad, Lock Nut Wrench,  
Wrench, Side Grip



<b>Continuous Rating Input</b> Input Kuasa Berterusan 额定输入功率	570W
<b>Wire Cup Brush</b> Berus Wayar Cawan 杯型钢丝刷	110mm (4-3/8")
<b>Abrasive Disc Size</b> Saiz Cakera 磨盘尺寸	150mm (6")
<b>No Load Speed (RPM)</b> Kelajuan Tanpa Beban 回转数	4,500
<b>Overall Length</b> Panjang Keseluruhan 总长度	225mm (8-7/8")
<b>Net Weight</b> Berat Bersih 净重	2.9kg (6.3lbs)
<b>Power Supply Cord</b> Kabel Wayar 电源线	2.5m (8.2ft)

## 9237C 180mm (7")

303 W

### Polisher

Penggilap  
打蜡机



- **Fast and powerful for clear coat finishes**  
Cepat dan berkuasa untuk kemasatan kot yang jelas  
快速清除涂层

**Standard Equipment:** Side Handle, Hex Wrench, Wool Pad



<b>Continuous Rating Input</b> Input Kuasa Berterusan 额定输入功率	1,200W
<b>Capacity</b> Kapasiti 能力	Wool Pad: 180mm (7") Wool Bonnet: 180mm (7")
<b>No Load Speed (RPM)</b> Kelajuan Tanpa Beban 回转数	0 - 3,200
<b>Dimensions (L x W x H)</b> Dimensi 体积	431x198x187mm (17"x7-3/4"x7-3/8")
<b>Net Weight</b> Berat Bersih 净重	3.2 - 3.4kg (7.0 - 7.5lbs)
<b>Power Supply Cord</b> Kabel Wayar 电源线	2.5m (8.2ft)

# GRINDING | SANDING

## PO5000C 125mm (5")

318

### Random Orbit Sander Pelicin Orbit 砂光机



- **Wide variety of optional accessories (Pad, Sponge pad, Felt pad, Wool pad)**  
Pelbagai aksesori pilihan (pad, pad sponge, pad felt, pad bulu)  
各种可选配件 (垫, 海绵垫, 毡垫, 羊毛垫)



PO5000C

Models and specs may vary by country

Standard Equipment: Hex Wrench



<b>Continuous Rating Input</b> Input Kuasa Berterusan 额定输入功率	900W
<b>Pad Size</b> Saiz Pad 垫大小	125mm (5")
<b>Orbits Per Minute (OPM)</b> Bilangan Putaran 轨道转速	0 - 6,800
<b>Strokes Per Minute (SPM)</b> Kelajuan Strok 冲程速度	0 - 13,600
<b>No Load Speed (RPM)</b> Kelajuan Tanpa Beban 回转数	0 - 780
<b>Orbit Diameter</b> Kelajuan Tanpa Beban 回转数	5.5 mm (7/32")
<b>Dimensions (L x W x H)</b> Dimensi 体积	451x123x134mm (17-3/4"x4-7/8"x5-1/4")
<b>Net Weight</b> Berat Bersih 净重	2.8 - 3.0kg (6.2 - 6.5lbs)
<b>Power Supply Cord</b> Kabel Wayar 电源线	4.0m (13.1ft)

## PO6000C 150mm (6")

### Random Orbit Sander Pelicin Orbit 砂光机



- **Wide variety of optional accessories (Pad, Sponge pad, Felt pad, Wool pad)**  
Pelbagai aksesori pilihan (pad, pad sponge, pad felt, pad bulu)  
各种可选配件 (垫, 海绵垫, 毡垫, 羊毛垫)



Standard Equipment: Hex Wrench



<b>Continuous Rating Input</b> Input Kuasa Berterusan 额定输入功率	900W
<b>Pad Size</b> Saiz Pad 垫大小	150mm (6")
<b>Orbits Per Minute (OPM)</b> Bilangan Putaran 轨道转速	0 - 6,800
<b>Strokes Per Minute (SPM)</b> Kelajuan Strok 冲程速度	0 - 13,600
<b>No Load Speed (RPM)</b> Kelajuan Tanpa Beban 回转数	0 - 780
<b>Orbit Diameter</b> Kelajuan Tanpa Beban 回转数	5.5mm (7/32")
<b>Dimensions (L x W x H)</b> Dimensi 体积	451x148x126mm (17-3/4"x5-7/8"x5")
<b>Net Weight</b> Berat Bersih 净重	2.8 - 3.0kg (6.2 - 6.5lbs)
<b>Power Supply Cord</b> Kabel Wayar 电源线	4.0m (13.1ft)

## PV7000C 180mm (7")

303

### Polisher Penggilap 抛光机



- **Lightweight for reduced operator fatigue**  
Ringan untuk mengurangkan keletihan pengguna  
轻量不易引起疲劳



Standard Equipment: Side Handle, Pad, Wrench



<b>Continuous Rating Input</b> Input Kuasa Berterusan 额定输入功率	900W
<b>Capacity</b> Kapasiti 能力	Pad: 180mm (7") Wool Bonnet: 180mm (7")
<b>No Load Speed (RPM)</b> Kelajuan Tanpa Beban 回转数	600 - 2,100
<b>Overall Length</b> Panjang Keseluruhan 总长度	210mm (8-1/4")
<b>Net Weight</b> Berat Bersih 净重	2.1kg (4.6lbs)
<b>Power Supply Cord</b> Kabel Wayar 电源线	2.5m (8.2ft)

## GD0600 6mm (1/4")

325

### Die Grinder Gerinda Lurus 电磨



- **Large Flush-Mount Paddle Switch for Comfortable Operation**  
Suis Flush-mount mudah digunakan  
大型平装式按钮开关易于操作



Standard Equipment: Wrench x2



<b>Continuous Rating Input</b> Input Kuasa Berterusan 额定输入功率	400W
<b>Capacity</b> Kapasiti 能力	Collet: 3,6mm or 1/8", 1/4"
<b>Wheel Diameter</b> Diameter Roda 轮片直径	38mm (1-1/2")
<b>No Load Speed (RPM)</b> Kelajuan Tanpa Beban 回转数	25,000
<b>Dimensions (L x W x H)</b> Dimensi 体积	358x82x82mm (14-1/8"x3-1/4"x3-1/4")
<b>Net Weight</b> Berat Bersih 净重	1.71 - 1.87kg (3.77 - 4.12lbs)
<b>Power Supply Cord</b> Kabel Wayar 电源线	2.5m (8.2ft)

## GD0601 6mm (1/4")

325

### Die Grinder Gerinda Lurus 电磨



- **Powerful 400W motor**  
Motor berkuasa 400W  
强力400W马达



Standard Equipment: Wrench x2



<b>Continuous Rating Input</b> Input Kuasa Berterusan 额定输入功率	400W
<b>Capacity</b> Kapasiti 能力	Collet: 3,6mm or 1/8", 1/4"
<b>Wheel Diameter</b> Diameter Roda 轮片直径	38mm (1-1/2")
<b>No Load Speed (RPM)</b> Kelajuan Tanpa Beban 回转数	25,000
<b>Dimensions (L x W x H)</b> Dimensi 体积	359x82x82mm (14-1/8"x3-1/4"x3-1/4")
<b>Net Weight</b> Berat Bersih 净重	1.68 - 1.84kg (3.70 - 4.06lbs)
<b>Power Supply Cord</b> Kabel Wayar 电源线	2.5m (8.2ft)

Cordless  
Tanpa Kabel 无线式LED Flashlight  
Lampu Cahaya LED  
LED照明灯Vacuum Cleaner  
Pembersih Vakuum  
吸尘器Drilling / Fastening  
Cairul / Pengikat  
钻孔 / 紧固Impact Drilling / Demolition  
Cairul / Pembongkaran  
冲击钻孔 / 拆毁施工Cutting  
Panasah  
切割Grinding / Sanding  
Pangkas / Poles  
研磨 / 打磨Sawing  
Gergaji  
锯切Planing / Routing  
Pegyalan / Tunggam  
刨削 / 雕刻Others  
Lain-lain  
其他Outdoor Power Equipment  
Alatan Kuasa Luar  
户外动力设备Makita  
MAKITA

# GRINDING | SANDING

## GD0603 6mm (1/4")

64

### Die Grinder

Gerinda Lurus  
电磨



- **Compact and easy handling**  
Padat dan mudah digunakan  
紧凑且易于使用



Standard Equipment: **Spanner, Wheel points**



<b>Continuous Rating Input</b> Input Kuasa Berterusan 额定输入功率	240W
<b>Capacity</b> Kapasiti 能力	Collet: 6mm or 1/4"
<b>Max Wheel Diameter</b> Diameter Roda 轮片直径	19mm (3/4")
<b>No Load Speed (RPM)</b> Kelajuan Tanpa Beban 回转数	28,000
<b>Diameter of Grip</b> Diameter Silinder 圆筒直径	65mm
<b>Dimensions (L x W x H)</b> Dimensi 体积	289x64x67mm (11-3/8"x2-1/2"x2-5/8")
<b>Net Weight</b> Berat Bersih 净重	0.98kg (2.16lbs)
<b>Power Supply Cord</b> Kabel Wayar 电源线	2.5m (8.2ft)

## GD0800C 8mm (1/4")

318

### Die Grinder

Gerinda Lurus  
电磨



- **Electronic Controller for Operator Convenience**  
Pengawal elektronik untuk kemudahan pengguna  
电子控制器方便使用者



Standard Equipment: **Wrench x2**

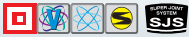

<b>Continuous Rating Input</b> Input Kuasa Berterusan 额定输入功率	750W
<b>Capacity</b> Kapasiti 能力	Collet: 3,6,8mm or 1/8", 1/4"
<b>Wheel Diameter</b> Diameter Roda 轮片直径	25mm (1")
<b>No Load Speed (RPM)</b> Kelajuan Tanpa Beban 回转数	7,000-28,000
<b>Dimensions (L x W x H)</b> Dimensi 体积	371x75x75mm (14-5/8"x2-15/16"x2-15/16")
<b>Net Weight</b> Berat Bersih 净重	1.88kg (4.14lbs)
<b>Power Supply Cord</b> Kabel Wayar 电源线	2.5m (8.2ft)

## GD0801C 8mm (1/4")

318

### Die Grinder

Gerinda Lurus  
电磨



- **Powerful 750W motor for faster material removal**  
Motor berkuasa 750W untuk pengisaran yang lebih cepat  
功率强大的 750W 马达提供更快的研磨



Standard Equipment: **Side Handle, Wrench x2**

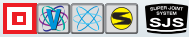

<b>Continuous Rating Input</b> Input Kuasa Berterusan 额定输入功率	750W
<b>Capacity</b> Kapasiti 能力	Collet: 8mm (1/4")
<b>Max Wheel Diameter</b> Diameter Roda 轮片直径	25mm (1")
<b>No Load Speed (RPM)</b> Kelajuan Tanpa Beban 回转数	7,000-29,000
<b>Dimensions (L x W x H)</b> Dimensi 体积	390x75x88mm (15-3/8"x2-15/16"x3-1/2")
<b>Net Weight</b> Berat Bersih 净重	1.96 - 1.97kg (4.32 - 4.34lbs)
<b>Power Supply Cord</b> Kabel Wayar 电源线	2.5m (8.2ft)

## GD0811C 8mm (1/4")

318

### Die Grinder

Gerinda Lurus  
电磨



- **Ideal for grinding internal surfaces, removing paint etc. using with flap wheel**  
Sesuai untuk mengisar permukaan dalaman, cat dan lain-lain  
适用于研磨内表面, 使用皮瓣轮去除油漆等



Standard Equipment: **Side Handle, Wrench x2**

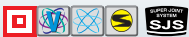

<b>Continuous Rating Input</b> Input Kuasa Berterusan 额定输入功率	750W
<b>Capacity</b> Kapasiti 能力	Collet: 8mm (1/4")
<b>Max Wheel Diameter</b> Diameter Roda 轮片直径	50mm (2")
<b>No Load Speed (RPM)</b> Kelajuan Tanpa Beban 回转数	1,800-7,000
<b>Dimensions (L x W x H)</b> Dimensi 体积	390x75x88mm (15-3/8"x2-15/16"x3-1/2")
<b>Net Weight</b> Berat Bersih 净重	1.99 - 2.00kg (4.39 - 4.41lbs)
<b>Power Supply Cord</b> Kabel Wayar 电源线	2.5m (8.2ft)

## GS5000 125mm (5")

204

### Straight Grinder

Pengisar Lurus  
直向砂轮机



- **Powerful 750W motor**  
Motor berkuasa 750W  
强力750W马达



Standard Equipment: **Hex Wrench, Wrench**



<b>Continuous Rating Input</b> Input Kuasa Berterusan 额定输入功率	750W
<b>Wheel Diameter</b> Diameter Roda 轮片直径	125mm (5")
<b>Hole Diameter</b> Diameter Lubang 孔直径	12.7, 20mm (1/2, 13/16")
<b>No Load Speed (RPM)</b> Kelajuan Tanpa Beban 回转数	5,600
<b>Dimensions (L x W x H)</b> Dimensi 体积	590x189x116mm (23-1/4"x7-7/16"x4-9/16")
<b>Net Weight</b> Berat Bersih 净重	5.0 - 5.2kg (11.0 - 11.5lbs)
<b>Power Supply Cord</b> Kabel Wayar 电源线	2.5m (8.2ft)

# GRINDING | SANDING

## GS6000 150mm (6")

204

### Straight Grinder

Pengisar Lurus  
直向砂轮机



- **Powerful 750W motor**  
Motor berkuasa 750W  
強力750W马达



Standard Equipment: Hex Wrench, Wrench



<b>Continuous Rating Input</b> Input Kuasa Berterusan 额定输入功率	750W
<b>Wheel Diameter</b> Diameter Roda 轮片直径	150mm (6")
<b>Hole Dia.</b> Diameter Lubang 孔直径	12.7, 20mm (1/2, 13/16")
<b>No Load Speed (RPM)</b> Kelajuan Tanpa Beban 回转数	5,600
<b>Dimensions (L x W x H)</b> Dimensi 体积	590x216x130mm (23-1/4"x8-1/2"x5-1/8")
<b>Net Weight</b> Berat Bersih 净重	5.2 - 5.4kg (11.4 - 12.0lbs)
<b>Power Supply Cord</b> Kabel Wayar 电源线	2.5m (8.2ft)

## TM3000C

459

### Multi Tool

Mesin Pemotong Berbilang Fungsi  
多功能切割打磨机



- **Powerful 320W motor with improved performance**  
Motor berkuasa 320W dengan prestasi yang lebih baik  
强力320W马达, 改进的性能



Standard Equipment: Hex Wrench



<b>Continuous Rating Input</b> Input Kuasa Berterusan 额定输入功率	320W
<b>Strokes Per Minute (SPM)</b> Kelajuan Strok 冲程速度	6,000-20,000
<b>Dimensions (L x W x H)</b> Dimensi 体积	275x64x92mm (10-7/8"x2-1/2"x3-5/8")
<b>Net Weight</b> Berat Bersih 净重	1.4 - 1.5kg (3.2 - 3.3lbs)
<b>Power Supply Cord</b> Kabel Wayar 电源线	5.0m (16.4ft)



## TM3010CX6

459

### Multi Tool

Mesin Pemotong Berbilang Fungsi  
多功能切割打磨机



- **Toolless clamp system for fast accessory installation**  
Sistem pemasangan aksesori tanpa alat  
免工具快速安装与更换配件



Standard Equipment: Multi Tool Plunge Cut Saw Blade 32, Segment Saw Blade 85, Sanding Pad

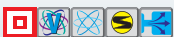

<b>Continuous Rating Input</b> Input Kuasa Berterusan 额定输入功率	320W
<b>Strokes Per Minute (SPM)</b> Kelajuan Strok 冲程速度	6,000-20,000
<b>Dimensions (L x W x H)</b> Dimensi 体积	283x68x87mm (11-1/8"x2-11/16"x3-7/16")
<b>Net Weight</b> Berat Bersih 净重	1.6 - 1.7kg (3.7 - 3.9lbs)
<b>Power Supply Cord</b> Kabel Wayar 电源线	2.5m (8.2ft)



## GB602 150mm (6")

### Bench Grinder

Pengisar  
台式砂轮机



- **Wheel covers have built-in task lights**  
Lampu tugas terbina dalam pelindung roda  
轮罩具有内置任务灯



Standard Equipment: Safety Eye Shield, Protection glasses, Wrench x2



<b>Continuous Rating Input</b> Input Kuasa Berterusan 额定输入功率	250W
<b>Wheel Diameter</b> Diameter Roda 轮片直径	150mm (6")
<b>Wheel Width</b> Lebar Roda 轮片宽度	16mm (5/8")
<b>Hole Dia.</b> Diameter Lubang 孔直径	12.7mm (1/2")
<b>H.P.</b>	1/3
<b>No Load Speed (RPM)</b> Kelajuan Tanpa Beban 回转数	2,850 (50Hz)/ 3,450 (60Hz)
<b>Dimensions (L x W x H)</b> Dimensi 体积	375x205x286mm (14-49/64"x8"x11-17/64")
<b>Net Weight</b> Berat Bersih 净重	9.31 - 9.08kg (20.02 - 20.52lbs)

## GB801 205mm (8")

### Bench Grinder

Pengisar  
台式砂轮机



- **Adjustable wheel balance feature reduces vibration**  
Pelarasanimbangan roda mengurangkan getaran  
平衡调整减少振动



Standard Equipment: Safety Eye Shield, Protection glasses, Wrench x2



<b>Continuous Rating Input</b> Input Kuasa Berterusan 额定输入功率	550W
<b>Wheel Diameter</b> Diameter Roda 轮片直径	205mm (8")
<b>Wheel Width</b> Lebar Roda 轮片宽度	19mm (3/4")
<b>Hole Dia.</b> Diameter Lubang 孔直径	15.88mm (5/8")
<b>H.P.</b>	3/4
<b>No Load Speed (RPM)</b> Kelajuan Tanpa Beban 回转数	2,850 (50Hz)/ 3,450 (60Hz)
<b>Dimensions (L x W x H)</b> Dimensi 体积	395x265x333mm (15-9/16"x10-7/16"x13-7/64")
<b>Net Weight</b> Berat Bersih 净重	19.91 - 19.63kg (43.89 - 43.28lbs)

Cordless  
Tempa Kord 无线电

LED Flashlight  
Lampu Suluh LED  
LED照明灯

Vacuum Cleaner  
Pembersih Vakuum  
吸尘器

Drilling / Fastening  
Cairul / Pengikat  
钻孔 / 紧固

Impact Drilling / Demolition  
Cairul / Hancurkan  
冲击钻孔 / 拆除施工

Cutting  
Pemotong  
切割

Grinding / Sanding  
Pangkas / Poles  
打磨 / 研磨

Sawing  
Gergaji  
锯切

Planing / Routing  
Peyataan / Tunggam  
刨削 / 雕刻

Others  
Lain-lain  
其他

Outdoor Power Equipment  
Alatan Kuat Luar  
户外动力设备

Makita  
MAKITA

# GRINDING | SANDING

## PC5010C 125mm (5")

### Concrete Planer

Pengampelas  
砂光机



- **Compact and Lightweight for High Production Work**

Kompak dan ringan untuk kerja pengeluan yang tinggi  
紧凑轻巧型，更有效率地工作

Standard Equipment: Lock Nut Wrench



<b>Continuous Rating Input</b> Input Kuasa Berterusan 额定输入功率	1,400W
<b>Wheel Diameter</b> Diameter Roda 轮片直径	125mm (5")
<b>Hole Diameter</b> Diameter Lubang 孔直径	22.23mm (7/8")
<b>No Load Speed (RPM)</b> Kelajuan Tanpa Beban 回转速	4,000 - 9,000
<b>Dimensions (L x W x H)</b> Dimensi 体积	350x231x179mm (13-3/4"x9-1/8"x7")
<b>Net Weight</b> Berat Bersih 净重	2.5 - 3.6kg (5.5 - 7.9lbs.)
<b>Power Supply Cord</b> Kabel Wayar 电源线	4.0m (13.1ft)

## PC5000C 125mm (5")

253 WMI

### Concrete Planer

Pengampelas  
砂光机



- **Electronic current limiter helps protect the motor from overload**

Penghadar arus elektronik melindungi motor daripada beban lampau  
电子电流限制器有助于防止马达超负荷

Standard Equipment: Lock Nut Wrench, Hex Wrench,  
Dust Bag Assembly



<b>Continuous Rating Input</b> Input Kuasa Berterusan 额定输入功率	1,400W
<b>Wheel Diameter</b> Diameter Roda 轮片直径	125mm (5")
<b>Hole Dia.</b> Diameter Lubang 孔直径	22.23mm (7/8")
<b>No Load Speed (RPM)</b> Kelajuan Tanpa Beban 回转速	10,000
<b>Dimensions (L x W x H)</b> Dimensi 体积	437x235x195mm (17-1/8"x9-1/4"x7-5/8")
<b>Net Weight</b> Berat Bersih 净重	4kg (8.9lbs)
<b>Power Supply Cord</b> Kabel Wayar 电源线	5.0m (16.4ft)

## PC5001C 125mm (5")

253 WMI

### Concrete Planer

Pengampelas  
砂光机



- **Soft start suppresses start-up reaction for more precision and longer tool life**

Penghidupan secara perlahan untuk ketepatan yang lebih baik dan memanjangkan hayat alat  
缓速启动提高准确性和延长工具使用寿命

Standard Equipment: Lock Nut Wrench, Hex Wrench,  
Dust Bag Assembly



<b>Continuous Rating Input</b> Input Kuasa Berterusan 额定输入功率	1,400W
<b>Wheel Diameter</b> Diameter Roda 轮片直径	125mm (5")
<b>No Load Speed (RPM)</b> Kelajuan Tanpa Beban 回转速	10,000
<b>Dimensions (L x W x H)</b> Dimensi 体积	479x182x195mm (18-13/16"x7-1/8"x7-5/8")
<b>Net Weight</b> Berat Bersih 净重	4kg (8.9lbs)
<b>Power Supply Cord</b> Kabel Wayar 电源线	5m (16.4ft)

## PW5001C 125mm (5")

318 WMI

### Stone Polisher

Penggilap Batu  
水磨石机



- **Variable speed control dial enables user to match the speed to the application**

Pilihan kawalan kelajuan berubah untuk pelbagai aplikasi  
变速控制选择适合多种应用

Standard Equipment: Rubber Pad, Side Grip, Wrench,  
Head Cover



<b>Continuous Rating Input</b> Input Kuasa Berterusan 额定输入功率	900W
<b>Capacity</b> Kapasiti 能力	Pad: 100-125mm (4-5")
<b>No Load Speed (RPM)</b> Kelajuan Tanpa Beban 回转速	2,000-4,000
<b>Overall Length</b> Panjang Keseluruhan 总长度	359mm (14-1/8")
<b>Net Weight</b> Berat Bersih 净重	2.3 - 2.6kg (5.1 - 5.7lbs)
<b>Power Supply Cord</b> Kabel Wayar 电源线	4.0m (13.1ft)

## 9404 100mm x 610mm (4" x 24")

303 WMI

### Belt Sander

Pengampelas  
带式砂光机



- **Powerful 1,010W motor for fast material removal**

Motor berkuasa 1,010W untuk pengisaran yang lebih cepat  
功率强大的 1,010W 马达提供更快的研磨

Standard Equipment: Abrasive Belt, Dust bag assembly



<b>Continuous Rating Input</b> Input Kuasa Berterusan 额定输入功率	1,010W
<b>Belt Size</b> Saiz Tali Pnggamp 皮带尺寸	100 x 610mm (4" x 24")
<b>Belt Speed</b> Kelajuan Tali Pnggamp 皮带速度	210-440m/min (690-1,440ft/min)
<b>Overall Length</b> Panjang Keseluruhan 总长度	334mm (13-1/8")
<b>Net Weight</b> Berat Bersih 净重	4.8kg (10.6lbs)
<b>Power Supply Cord</b> Kabel Wayar 电源线	5.0m (16.4ft)



# GRINDING | SANDING

## 9903 76mm x 533mm (3" x 21")

303

### Belt Sander Pengampelas 带式砂光机



- Sands wood or metal and removes paint and rust  
Melicinkan kayu atau logam, menghilangkan cat dan karat  
打磨木头或金属，去除油漆和铁锈



Standard Equipment: Abrasive Belt, Dust bag assembly



<b>Continuous Rating Input</b> Input Kuasa Berterusan 额定输入功率	1,010W
<b>Belt Size</b> Saiz Tali Pinggang 皮带尺寸	76 x 533mm (3" x 21")
<b>Belt Speed</b> Kelajuan Tali Pinggang 皮带速度	210 - 440m/min (690 - 1,440 ft/min)
<b>Overall Length</b> Panjang Keseluruhan 总长度	296mm (11-5/8")
<b>Net Weight</b> Berat Bersih 净重	4.3kg (9.5lbs)
<b>Power Supply Cord</b> Kabel Wayar 电源线	5.0m (16.4ft)

## 9401 100mm x 610mm (4" x 24")

153

### Belt Sander Pengampelas 带式砂光机



- Highly-efficient dust collection system for clean work environment  
Sistem pengumpulan habuk yang cekap untuk mewujudkan persekitaran kerja bersih  
高效的集尘系统打造清洁工作环境



Standard Equipment: Abrasive Belt, Carbon Plate, Step, Dust bag assembly



<b>Continuous Rating Input</b> Input Kuasa Berterusan 额定输入功率	940W
<b>Belt Size</b> Saiz Tali Pinggang 皮带尺寸	100 x 610mm (4" x 24")
<b>Belt Speed</b> Kelajuan Tali Pinggang 皮带速度	350m/min (1,150ft/min)
<b>Overall Length</b> Panjang Keseluruhan 总长度	374mm (14-3/4")
<b>Net Weight</b> Berat Bersih 净重	7.2kg (15.9lbs)
<b>Power Supply Cord</b> Kabel Wayar 电源线	5.0m (16.4ft)

## 9924DB 76mm x 610mm (3" x 24")

100

### Belt Sander Pengampelas 带式砂光机



- Powerful 850W for fast material removal  
Motor berkuasa 750W untuk pengiraan yang lebih cepat  
功率强大的 750W 马达提供更快的研磨



Standard Equipment: Abrasive Belt, Carbon Plate, Dust bag assembly



<b>Continuous Rating Input</b> Input Kuasa Berterusan 额定输入功率	850W
<b>Belt Size</b> Saiz Tali Pinggang 皮带尺寸	76 x 610, 620mm (3" x 24, 24-3/8")
<b>Belt Speed</b> Kelajuan Tali Pinggang 皮带速度	400m/min (1,300ft/min)
<b>Overall Length</b> Panjang Keseluruhan 总长度	355mm (14")
<b>Net Weight</b> Berat Bersih 净重	4.8kg (10.6lbs)
<b>Power Supply Cord</b> Kabel Wayar 电源线	5.0m (16.4ft)

## 9911 76mm x 457mm (3" x 18")

411

### Belt Sander Pengampelas 带式砂光机



- Compact and well balanced for easy operation  
Padat dan mudah digunakan  
紧凑且易于使用



Standard Equipment: Abrasive Belt, Dust bag assembly



<b>Continuous Rating Input</b> Input Kuasa Berterusan 额定输入功率	650W
<b>Belt Size</b> Saiz Tali Pinggang 皮带尺寸	76 x 457mm (3" x 18")
<b>Belt Speed</b> Kelajuan Tali Pinggang 皮带速度	75 - 270m/min (250 - 900ft/min)
<b>Overall Length</b> Panjang Keseluruhan 总长度	262mm (10-3/8")
<b>Net Weight</b> Berat Bersih 净重	2.7kg (6lbs)
<b>Power Supply Cord</b> Kabel Wayar 电源线	2.5m (8.2ft)

## 9031 30mm x 533mm (1-3/16" x 21")

411

### Belt Sander Pengampelas 带式砂光机



- Versatile for use on wood, metal, and fiberglass materials  
Digunakan pada bahan kayu, logam, dan gentian kaca  
多用于木材，金属和纤维玻璃材料



Standard Equipment: Abrasive Belt x10, Side Handle



<b>Continuous Rating Input</b> Input Kuasa Berterusan 额定输入功率	550W
<b>Belt Size</b> Saiz Tali Pinggang 皮带尺寸	30 x 533mm (1-1/8" x 21")
<b>Belt Speed</b> Kelajuan Tali Pinggang 皮带速度	200 - 1,000m/min (656 - 3,280ft/min)
<b>Overall Length</b> Panjang Keseluruhan 总长度	380mm (15")
<b>Net Weight</b> Berat Bersih 净重	2.1kg (4.6lbs)
<b>Power Supply Cord</b> Kabel Wayar 电源线	2.5m (8.2ft)

Cordless  
Tempa Kord 无线式

LED Flashlight  
Lampu Suluh LED  
LED照明灯

Vacuum Cleaner  
Pembersih Vakuum  
吸尘器

Drilling / Fastening  
Cairul / Pasang  
钻孔 / 紧固

Impact Drilling / Demolition  
Cairul / Hancurkan  
冲击钻孔 / 拆除施工

Cutting  
Panasah  
切割

Grinding / Sanding  
Pangkas / Poles  
研磨 / 砂磨

Sawing  
Gergaji  
锯切

Planing / Routing  
Pangkas / Tangkai  
刨削 / 雕刻

Others  
Lain-lain  
其他

Outdoor Power Equipment  
Alatan Kuasa Luar  
户外动力设备

Makita  
MAKITA

# GRINDING | SANDING

## BO3710

64

### Finishing Sander

Pengampelas  
砂光机



- **High capacity dust bag with built-in vacuum adaptor for improved dust collection**  
Beg debu kapasiti tinggi dengan penyesuai vakum terbina dalam untuk pengumpulan habuk yang lebih baik  
内置空适配器的高容量集尘袋可改进集尘效果

Standard Equipment: Dust Bag, Punch Plate



<b>Continuous Rating Input</b> Input Kuasa Berterusan 额定输入功率	190W
<b>Pad Size</b> Saiz Pad 垫大小	93 x 185mm (3-5/8" x 7-1/4")
<b>Abrasive Paper Size</b> Saiz Kertas Pasir 砂纸尺寸	93 x 228mm (3-5/8" x 9")
<b>Orbits Per Minute (OPM)</b> Bilangan Putaran 轨道转速	11,000
<b>Strokes Per Minute (SPM)</b> Kelajuan Strok 冲程速度	22,000
<b>Orbit Diameter</b> Jejaki Diameter 轨道直径	2.0mm (1/16")
<b>Dimensions (L x W x H)</b> Dimensi 体积	253x92x154mm (10"x3-5/8"x6-1/16")
<b>Net Weight</b> Berat Bersih 净重	1.6kg (3.5lbs)
<b>Power Supply Cord</b> Kabel Wayar 电源线	2.0m (6.6ft)

## 9035H

### Finishing Sander

Pengampelas  
砂光机



- **Rubberized large paper clamp levers for easy installation/removal of paper**  
Batang pengapit getah yang besar memudahkan pemasangan dan penyingkiran kertas pasir  
大号橡胶夹杆方便安装及取出砂纸

Standard Equipment: Abrasive paper x6



<b>Continuous Rating Input</b> Input Kuasa Berterusan 额定输入功率	180W
<b>Pad Size</b> Saiz Pad 垫大小	93 x 185mm (3-5/8" x 7-1/4")
<b>Abrasive Paper Size</b> Saiz Kertas Pasir 砂纸尺寸	93 x 228mm (3-5/8" x 9")
<b>Orbits Per Minute (OPM)</b> Kelajuan Ayunan 摆动速度	11,000
<b>Dimensions (L x W x H)</b> Dimensi 体积	236x93x146mm (9-1/4"x3-5/8"x5-3/4")
<b>Net Weight</b> Berat Bersih 净重	1.5kg (3.3lbs)
<b>Power Supply Cord</b> Kabel Wayar 电源线	2.5m (8.2ft)

## BO4901

419

### Finishing Sander

Pengampelas  
砂光机



- **Large clamp lever for easy install/removal of paper**  
Batang pengapit yang besar memudahkan pemasangan dan penyingkiran kertas pasir  
大夹杆方便安装及取出砂纸

Standard Equipment: Abrasive Paper



<b>Continuous Rating Input</b> Input Kuasa Berterusan 额定输入功率	330W
<b>Pad Size</b> Saiz Pad 垫大小	115 x 229mm (4-1/2" x 9")
<b>Abrasive Paper Size</b> Saiz Kertas Pasir 砂纸尺寸	115 x 280mm (4-1/2" x 11")
<b>Orbits Per Minute (OPM)</b> Kelajuan Ayunan 摆动速度	10,000
<b>Overall Length</b> Panjang Keseluruhan 总长度	289mm (11-3/8")
<b>Net Weight</b> Berat Bersih 净重	2.8kg (6.2lbs)
<b>Power Supply Cord</b> Kabel Wayar 电源线	2.5m (8.2ft)

## 9045B 114mm (4-1/2")

105

### Finishing Sander

Pengampelas  
砂光机



- **All bearing construction for smooth, long term operation**  
Konstruksi galas yang sesuai untuk operasi lancar dan jangka panjang  
适合平滑及长期运行的轴承结构

Standard Equipment: Abrasive paper x10



<b>Continuous Rating Input</b> Input Kuasa Berterusan 额定输入功率	520W
<b>Pad Size</b> Saiz Pad 垫大小	114 x 234mm (4-1/2" x 9-1/4")
<b>Abrasive Paper Size</b> Saiz Kertas Pasir 砂纸尺寸	114 x 280mm (4-1/2" x 11")
<b>Orbits Per Minute (OPM)</b> Kelajuan Ayunan 摆动速度	10,000
<b>Overall Length</b> Panjang Keseluruhan 总长度	240mm (9-1/2")
<b>Orbit Diameter</b> Jejaki Diameter 轨道直径	2.4mm (3/32")
<b>Net Weight</b> Berat Bersih 净重	2.6kg (5.7lbs)
<b>Power Supply Cord</b> Kabel Wayar 电源线	2.5m (8.2ft)

## BO4510H

### Finishing Sander

Pengampelas  
砂光机



- **Large clamp lever for easy install/removal of paper**  
Batang pengapit yang besar memudahkan pemasangan dan penyingkiran kertas pasir  
大夹杆方便安装及取出砂纸

Standard Equipment: Abrasive paper x6



<b>Continuous Rating Input</b> Input Kuasa Berterusan 额定输入功率	170W
<b>Pad Size</b> Saiz Pad 垫大小	110 x 100mm (4-5/16" x 3-15/16")
<b>Abrasive Paper Size</b> Saiz Kertas Pasir 砂纸尺寸	114 x 140mm (4-1/2" x 5-1/2")
<b>Orbits Per Minute (OPM)</b> Bilangan Putaran 轨道转速	12,000
<b>Dimensions (L x W x H)</b> Dimensi 体积	116x110x129mm (4-9/16"x4-5/16"x5-1/8")
<b>Net Weight</b> Berat Bersih 净重	1.1kg (2.4lbs)
<b>Power Supply Cord</b> Kabel Wayar 电源线	2.5m (8.2ft)

# GRINDING | SANDING

## BO4556

419

### Finishing Sander Pengampelas 砂光机



- 14,000OPM for fast and smooth finish sanding  
14,000OPM untuk pelicinan cepat dan lancar  
14,000OPM可快速平滑的打磨

Standard Equipment: Abrasive Paper, Dust Bag, Punch Plate



<b>Continuous Rating Input</b> Input Kuasa Berterusan 额定输入功率	200W
<b>Pad Size</b> Saiz Pad 垫大小	112 x 102mm (4-3/8" x 4")
<b>Abrasive Paper Size</b> Saiz Kertas Pasir 砂纸尺寸	114 x 140mm (4-1/2" x 5-1/2")
<b>Orbits Per Minute (OPM)</b> Bilangan Putaran 轨道转速	14,000
<b>Dimensions (L x W x H)</b> Dimensi 体积	131x112x141mm (5-1/8"x4-3/8"x5-9/16")
<b>Net Weight</b> Berat Bersih 净重	1.1kg (2.5lbs)
<b>Power Supply Cord</b> Kabel Wayar 电源线	2.0m (6.6ft)

## BO6050J

325

### Random Orbit Sander Pengampelas 砂光机



- Slim skirt provides higher work efficiency  
in tight spaces  
Kecekapan kerja yang lebih tinggi di ruang yang sempit  
在狭小空间中提供更高的工作效率

Standard Equipment:  
Abrasive Paper, Side Grip



BO6050

VIDEO CLIP  
Modes and specs  
may vary by country



<b>Continuous Rating Input</b> Input Kuasa Berterusan 额定输入功率	750W
<b>Pad Diameter</b> Saiz Pad 垫大小	150mm (6")
<b>Abrasive Disc Size</b> Saiz Cakera 磨盘尺寸	150mm (6")
<b>Orbits Per Minute (OPM)</b> Bilangan Putaran 轨道转速	1,600 - 6,800
<b>Sanding Strokes Per Minute (SPM)</b> Menggilap Strok Seminit 每分钟打磨冲程	3,200 - 13,600
<b>Pad Speed in Roto-orbit mode (rpm)</b> Kelajuan Pad 垫速度	140 - 600
<b>Orbit Diameter</b> Jejaki Diameter 轨道直径	5.5mm (7/32")
<b>Dimensions (L x W x H)</b> Dimensi 体积	330x155x145mm (13"x6-1/8"x5-3/4")
<b>Net Weight</b> Berat Bersih 净重	2.6kg (5.7lbs)
<b>Power Supply Cord</b> Kabel Wayar 电源线	2.5m (8.2ft)

## BO5031

419

### Random Orbit Sander Pengampelas 砂光机



- Smooth finish with variable speed control  
Kemasan lancar dengan kawalan kelajuan yang pelbagai  
变速控制

Standard Equipment: Abrasive Paper, Dust Bag



<b>Continuous Rating Input</b> Input Kuasa Berterusan 额定输入功率	300W
<b>Pad Diameter</b> Saiz Pad 垫大小	123mm (4-7/8")
<b>Abrasive Disc Size</b> Saiz Cakera 磨盘尺寸	125mm (5")
<b>Orbits Per Minute (OPM)</b> Bilangan Putaran 轨道转速	4,000-12,000
<b>Dimensions (L x W x H)</b> Dimensi 体积	153x123x153mm (6"x4-7/8"x6")
<b>Net Weight</b> Berat Bersih 净重	1.3kg (3lbs)
<b>Power Supply Cord</b> Kabel Wayar 电源线	2.0m (6.6ft)

## BO5041

64

### Random Orbit Sander Pengampelas 砂光机



- More power for faster sanding and  
a smooth finish  
Lebih berkuasa untuk pelicinan cepat dan lancar  
更快速的打磨

Standard Equipment: Abrasive Paper, Dust Bag



<b>Continuous Rating Input</b> Input Kuasa Berterusan 额定输入功率	300W
<b>Pad Diameter</b> Saiz Pad 垫大小	123mm (4-7/8")
<b>Abrasive Disc Size</b> Saiz Cakera 磨盘尺寸	125mm (5")
<b>Orbits Per Minute (OPM)</b> Bilangan Putaran 轨道转速	4,000-12,000
<b>Dimensions (L x W x H)</b> Dimensi 体积	218x123x153mm (8-5/8"x4-7/8"x6")
<b>Net Weight</b> Berat Bersih 净重	1.4kg (3.1lbs)
<b>Power Supply Cord</b> Kabel Wayar 电源线	2.0m (6.6ft)

Cordless  
Tempat Kord 无线式

LED Flashlight  
Lampu Suluh LED  
LED照明灯

Vacuum Cleaner  
Pembersih Vakuum  
吸尘器

Drilling / Fastening  
Cairul / Pengikat  
钻孔 / 紧固

Impact Drilling / Demolition  
Cairul / Penebuk  
冲击钻孔 / 拆毁动工

Cutting  
Panasah  
切割

Grinding / Sanding  
Pangkas / Poles  
研磨 / 打磨

Sawing  
Gergaji  
锯切

Planing / Routing  
Pegyalan / Tunggam  
刨削 / 雕刻

Others  
Lain-lain  
其他

Outdoor Power Equipment  
Alatan Kuasa Luar  
户外动力工具

Makita  
191111

Cordless  
Tangan Kordless

LED Flashlight  
Lampu Suhu LED  
LED 照前灯

Vacuum Cleaner  
Pembersih Vakum  
吸尘器

Drilling | Fastening  
Drill / Pengikat  
钻机 / 螺丝

Impact Drilling | Demolition  
Drill / Pemukul  
冲击钻机 / 拆除加工

Cutting  
Pemotong  
切割机

Grinding | Sanding  
Pengkilan / Habis  
打磨 / 砂磨

Sawing  
Gergaji  
锯切

Planing | Routing  
Pengaliran / Rangkaian  
刨削 / 雕刻

Others  
Lain-lain  
其他

Outdoor Power Equipment  
Alat-alat Tenaga Luar  
园具 / 户外

Makita  
makita

# SAWING

Gergaji 锯切



## LS1019L 260mm (10-1/4")

153 W

### Slide Compound Miter Saw

Gergaji Komaun Miter  
斜断锯



- **Large turn base supports workpiece securely for increased stability**  
Dasar besar untuk menyokong bahan kerja dengan stabil  
大转动底座稳定地支撑工件

**Standard Equipment:** EFFICUT Saw Blade, Dust Bag, Triangular Rule, Vertical Vise, Hex Wrench



<b>Continuous Rating Input</b> Input Kuasa Berterusan 额定输入功率	1,510W
<b>Blade Diameter</b> Diameter Bilah 锯片直径	260mm (10-1/4")
<b>Bevel Angle</b> Sudut Bevel 斜角	48°L / 48°R
<b>Miter Angle</b> Sudut Miter 斜接角	60°L / 60°R
<b>Max Cutting Capacity</b> Kapasiti Pemotongan Maksimum 最大切割能力	Crown Molding Vertically Nested: 168mm (6-5/8") Crown Molding Lying Flat: 248mm (9-3/4") Base Board Against Fence: 133mm (5-1/4") Base Board Lying Flat: 305mm (12")
<b>No Load Speed (RPM)</b> Kelajuan Tanpa Beban 回转数	3,200
<b>Dimensions (L x W x H)</b> Dimensi 体积	805x644x660mm (31-3/4"x25-3/8"x26")
<b>Net Weight</b> Berat Bersih 净重	26.3kg (57.9lbs.)
<b>Power Supply Cord</b> Kabel Wayar 电源线	2.5m (8.2ft.)

## LS1219L 305mm (12")

153 W

### Slide Compound Miter Saw

Gergaji Komaun Miter  
斜断锯



- **Dual dust collection ports provide excellent dust extraction performance**  
Dua pengumpul habuk untuk prestasi pengekstrakan habuk yang sangat baik  
双重集尘口提供出色的除尘性能

**Standard Equipment:** TCT Saw Blade (B-67474), Vertical Vise, Hex Wrench, Triangular Rule, Dust Bag



<b>Continuous Rating Input</b> Input Kuasa Berterusan 额定输入功率	1,800W
<b>Blade Diameter</b> Diameter Bilah 锯片直径	305mm (12")
<b>Hole Diameter</b> Diameter Lubang 孔直径	European Countries: 30mm (1-3/16") Others: 25.4mm (1")
<b>Angle</b> Sudut 角度	Bevel 48° L / 48° R Miter 60° L / 60° R
<b>Max Cutting Capacity</b> Kapasiti Pemotongan Maksimum 最大切割能力	Crown Molding Vertically Nested: 203mm (8") Crown Molding Lying Flat: 320mm (12-5/8") Base Board Against Fence: 171mm (6-3/4") Base Board Lying Flat: 416mm (16-3/8")
<b>No Load Speed (RPM)</b> Kelajuan Tanpa Beban 回转数	3,200
<b>Dimensions (L x W x H)</b> Dimensi 体积	898x664x725mm (35-1/4"x26-1/8"x28-1/2")
<b>Net Weight</b> Berat Bersih 净重	29.5kg (65.0lbs)
<b>Power Supply Cord</b> Kabel Wayar 电源线	2.5m (8.2ft)

## LS1018L 260mm (10-1/4")

### Slide Compound Saw

Gergaji Komaun Miter  
斜断锯



- **Large cutting capacity in a compact design and less weight**  
Kapasiti pemotongan besar dalam reka bentuk kompak dan ringan  
设计紧凑, 轻量, 切割能力大

**Standard Equipment:** TCT Saw Blade (B-14277), Vertical Vise, Socket Wrench, Triangular Rule, Dust Bag, Holder assembly



<b>Continuous Rating Input</b> Input Kuasa Berterusan 额定输入功率	1,430W
<b>Blade Diameter</b> Diameter Bilah 锯片直径	255 - 260mm (10 - 10-1/4")
<b>Miter Angle</b> Sudut Miter 斜接角	47°L / 60°R
<b>Bevel Angle</b> Sudut Bevel 斜角	45°L / 45°R
<b>Max Cutting Capacity</b> Kapasiti Pemotongan Maksimum 最大切割能力	90°: 91 x 305mm (3-5/8" x 12") 45°: 91 x 215mm (3-5/8" x 8-1/2")
<b>No Load Speed (RPM)</b> Kelajuan Tanpa Beban 回转数	4,300
<b>Dimensions (L x W x H)</b> Dimensi 体积	825x536x633mm (32-1/2"x21-1/8"x25")
<b>Net Weight</b> Berat Bersih 净重	20.6kg (45.4lbs)
<b>Power Supply Cord</b> Kabel Wayar 电源线	2.5m (8.2ft)

## LS1040 260mm (10-1/4")

153 W

### Compound Miter Saw

Gergaji Komaun Miter  
斜断锯



- **Powerful 1,650W direct drive motor for improved performance**  
Motor 1,650W yang berkuasa meningkatkan prestasi  
功率强劲的1,650W直驱马达提高了性能

**Standard Equipment:** Socket Wrench, Dust Bag, Holder Set, Vertical Vise, Triangular Rule



<b>Continuous Rating Input</b> Input Kuasa Berterusan 额定输入功率	1,650W
<b>Blade Diameter</b> Diameter Bilah 锯片直径	260mm (10-1/4")
<b>Miter Angle</b> Sudut Miter 斜接角	45°L / 52°R
<b>Bevel Angle</b> Sudut Bevel 斜角	45°L
<b>Max Cutting Capacity</b> Kapasiti Pemotongan Maksimum 最大切割能力	90°: 90.5 x 95mm (3-9/16" x 3-3/4") 45°: 90.5 x 67mm (3-9/16" x 2-5/8")
<b>No Load Speed (RPM)</b> Kelajuan Tanpa Beban 回转数	4,600
<b>Dimensions (L x W x H)</b> Dimensi 体积	530x476x532mm (20-7/8"x18-3/8"x21")
<b>Net Weight</b> Berat Bersih 净重	12.4kg (27.3lbs)
<b>Power Supply Cord</b> Kabel Wayar 电源线	2.5m (8.2ft)

# SAWING

## LS0714 190mm (7-1/2") 153

**Slide Compound Saw**  
Gergaji Kompaun Miter  
斜断锯



- Compact and Lightweight for Increased Jobsite Portability  
Kompak dan Ringan  
小巧轻便

**Standard Equipment:** Carbide-Tipped Saw Blade, Dust Bag, Holder Set, Vertical Vise, Triangular Rule



<b>Continuous Rating Input</b> Input Kuasa Berterusan 额定输入功率	1,010W
<b>Blade Diameter</b> Diameter Bilah 锯片直径	190mm (7-1/2")
<b>Miter Angle</b> Sudut Miter 斜接角	47°L / 57°R
<b>Bevel Angle</b> Sudut Bevel 斜角	45°L / 5°R
<b>Max Cutting Capacity</b> Kapasiti Pemotongan Maksimum 最大切割能力	90°: 52 x 300mm (2-1/16" x 11-3/4") 45°: 52 x 212mm (2-1/16" x 8-3/8")
<b>No Load Speed (RPM)</b> Kelajuan Tanpa Beban 回转数	6,000
<b>Dimensions (L x W x H)</b> Dimensi 体积	670x430x458mm (26-3/8"x17"x18")
<b>Net Weight</b> Berat Bersih 净重	13.1kg (28.9lbs)
<b>Power Supply Cord</b> Kabel Wayar 电源线	2.5m (8.2ft)

## LS1440 355mm (14") 153

**Miter Saw**  
Gergaji Miter  
斜断锯



- Large cutting capacity  
Kapasiti pemotongan besar  
大切割能力

**Standard Equipment:** Socket Wrench, Vise Assembly, Dust Bag, Holder Set



<b>Continuous Rating Input</b> Input Kuasa Berterusan 额定输入功率	1,380W
<b>Max Cutting Capacity</b> Kapasiti Pemotongan Maksimum 最大切割能力	90°: 122 x 152mm (4-13/16" x 6") 45°: 122 x 115mm (4-13/16" x 4-1/2")
<b>Blade Diameter</b> Diameter Bilah 锯片直径	355mm (14")
<b>No Load Speed (RPM)</b> Kelajuan Tanpa Beban 回转数	3,200
<b>Dimensions (L x W x H)</b> Dimensi 体积	530x596x435mm (20-7/8"x23-1/2"x17-1/8")
<b>Net Weight</b> Berat Bersih 净重	34.2kg (75.4lbs)
<b>Power Supply Cord</b> Kabel Wayar 电源线	2.5m (8.2ft)

### MAXIMUM CUTTING CAPACITY

Kapasiti Pemotongan Maksimum 最大切割能力

Model No.	Base Angle	Blade Angle Left 45°	Blade Angle 0°	Blade Angle Right 5°	Blade Angle Right 45°
LS0714	0°	40x300mm	52x300mm	40x300mm	-
	Left / Right 45°	40x212mm	52x212mm	-	-
	-	-	-	-	-
	Right 57°	-	52x163mm	-	-
LS1018L	0°	50x305mm	91x305mm	-	31x305mm
	Left / Right 45°	50x215mm	91x215mm	-	31x215mm
	-	-	-	-	-
	Right 60°	-	91x150mm	-	-
LS1019L	0°	47x305, 61x279mm	71x305, 91x279mm	-	29x305, 43x279mm
	Left / Right 45°	47x215, 61x197mm	71x215, 91x197mm	-	29x215, 43x197mm
	Left / Right 60°	-	71x152, 91x139mm	-	-
	-	-	-	-	-
LS1219L	0°	71x363mm	107x363mm	-	54x363mm
	Left / Right 45°	71x255mm	107x255mm	-	54x255mm
	Left / Right 60°	-	107x178mm	-	-
	-	-	-	-	-
LS1040	0°	48x95mm	90.5x95mm	-	-
	Left / Right 45°	48x67mm	90.5x67mm	-	-
	-	-	-	-	-
	-	-	-	-	-
LH1201FL	0°	64x155mm	95x155mm	-	-
	Left 45°	64x65mm	95x110mm	-	-
	Right 45°	40x125mm	95x110mm	-	-
	Cutting capacity as table saw: 52mm				

## LH1201FL 305mm (12")

**Table Top Miter Saw**  
Gergaji Miter  
两用平台斜切锯



- 2 tools in 1 for convenience and versatility  
Alat 2 dalam 1  
1机2用

**Standard Equipment:** TCT Saw Blade, Vertical Vise, Dust Bag, Rip Fence, Ring, Triangular Rule, Push Stick, Blade Cover, Socket Wrench, Holder Set



<b>Continuous Rating Input</b> Input Kuasa Berterusan 额定输入功率	1,650W
<b>Blade Diameter</b> Diameter Bilah 锯片直径	305mm (12")
<b>Miter Angle</b> Sudut Miter 斜接角	47°L / 52°R
<b>Bevel Angle</b> Sudut Bevel 斜角	45°L
<b>Max Cutting Capacity</b> Kapasiti Pemotongan Maksimum 最大切割能力	90°: 62 x 200mm (2-7/16" x 7-7/8") 90°: 95 x 155mm (3-3/4" x 6-1/8") 45° Miter, L/R: 62 x 135mm (2-7/16" x 5-5/16") 45° Miter, L/R: 95 x 110mm (3-3/4" x 4-5/16") 90°, Table saw: 52mm (2-1/16")
<b>No Load Speed (RPM)</b> Kelajuan Tanpa Beban 回转数	3,800
<b>Dimensions (L x W x H)</b> Dimensi 体积	610x535x692mm (24"x21"x27-1/4") Table Size (W x L): 307 x 465mm (12-1/8" x 18-1/4")
<b>Net Weight</b> Berat Bersih 净重	20.9kg (46.1lbs)
<b>Power Supply Cord</b> Kabel Wayar 电源线	2.5m (8.2ft)

Cordless  
Tenggak 30.6A

LED Flashlight  
Lampu Suluh LED  
LED 照明灯

Vacuum Cleaner  
Penyerap Debu  
吸尘器

Drilling / Fastening  
Gergaji / Pengikat  
钻孔 / 紧固

Impact Drilling / Demolition  
Gergaji / Pemusnah  
冲击钻孔 / 拆除施工

Cutting  
Pemotongan  
切割

Grinding / Sanding  
Pengiraian / Pasir  
打磨 / 砂磨

Sawing  
Gergaji  
锯切

Planing / Routing  
Pegayaan / Tanggapan  
刨削 / 雕刻

Others  
Lain-lain  
其他

Outdoor Power Equipment  
Alatan Kerja Luar  
户外动力工具



# SAWING

## LF1000 260mm (10-1/4")

153 

### Flip Over Saw

Gergaji Flip  
翻转锯



- **Quick miter saw/ table saw conversion**  
Konversi gergaji miter & gergaji meja  
斜割锯及台锯快速转换

**Standard Equipment:** Rip Fence, Miter Gauge, Push Stick, Top Cover Assy (Top Blade Guard), Dust Cover, Dust Bag, Wrench 8



<b>Continuous Rating Input</b> Input Kuasa Berterusan 额定输入功率	1,650W
<b>Max Cutting Capacity</b> Kapasiti Pemotongan Maksimum 最大切割能力	90°: 20 x 210mm (13/16" x 8-1/4") 90°: 68 x 155mm (2-11/16" x 6-1/8") 45°: 50 x 150mm (2" x 5-7/8")
<b>Blade Diameter</b> Diameter Bilah 锯片直径	260mm (10-1/4")
<b>No Load Speed (RPM)</b> Kelajuan Tanpa Beban 回转速数	2,700
<b>Dimensions (L x W x H)</b> Dimensi 体积	Miter saw : 660x650x1,220mm (26"x25-1/2"x48") Table saw : 660x650x1,060mm (26"x25-1/2"x41-3/4")
<b>Net Weight</b> Berat Bersih 净重	36.0 kg (79.4 lbs)
<b>Power Supply Cord</b> Kabel Wayar 电源线	2.5 m (8.2 ft)

## 2704 260mm (10-1/4")

153 

### Table Saw

Gergaji Meja  
台锯

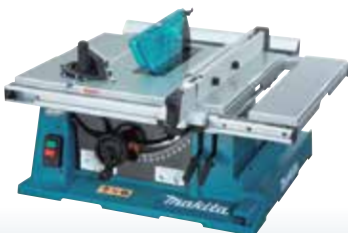

- **Electric brake for increased productivity and operator safety**  
Brek Elektrik untuk peningkatan produktiviti dan pengendalian keselamatan  
电子自动刹车提高生产率和操作安全

**Standard Equipment:** Carbide-Tipped Saw Blade (B-17734), Rip Fence, Miter Gauge, Wrenches, Push Stick, Ring



<b>Continuous Rating Input</b> Input Kuasa Berterusan 额定输入功率	1,650W
<b>Max Cutting Capacity</b> Kapasiti Pemotongan Maksimum 最大切割能力	90°: 93mm (3-5/8") 45°: 64mm (2-1/2")
<b>Blade Diameter</b> Diameter Bilah 锯片直径	260mm (10-1/4")
<b>No Load Speed (RPM)</b> Kelajuan Tanpa Beban 回转速数	4,800
<b>Dimensions (L x W x H)</b> Dimensi 体积	665x766x344mm (26-1/4"x30-1/4"x13-1/2")
<b>Net Weight</b> Berat Bersih 净重	35.6 - 37.3kg (78.5 - 82.3lbs.)
<b>Power Supply Cord</b> Kabel Wayar 电源线	2.5m (8.2ft)

## MLT100 260mm (10-1/4")

### Table Saw

Gergaji Meja  
台锯



- **Right and rear extension table enables greater cutting capacity**  
Meja tambahan kanan dan belakang membolehkan kapasiti pemotongan yang lebih besar  
右侧和后侧延伸台具有更大的切割能力

**Standard Equipment:** Carbide-Tipped Saw Blade, Rip Fence, Miter Gauge, Wrenches, Push Stick, Triangular Rule



<b>Continuous rating input</b> Input Kuasa Berterusan 额定输入功率	1,500W
<b>Max Cutting Capacity</b> Kapasiti Pemotongan Maksimum 最大切割能力	90°: 91mm (3-9/16") 45°: 63mm (2-1/2")
<b>Blade Diameter</b> Diameter Bilah 锯片直径	260mm (10-1/4")
<b>No Load Speed (RPM)</b> Kelajuan Tanpa Beban 回转速数	4,300
<b>Dimensions (L x W x H)</b> Dimensi 体积	726x984x333mm (28-1/2"x38-3/4"x13-1/8")
<b>Net weight</b> Berat Bersih 净重	34.1kg (75.2lbs)
<b>Power supply cord</b> Kabel Wayar 电源线	2.5m (8.2ft)

## 2712 315mm (12-3/8")

### Table Saw

Gergaji Meja  
台锯



- **Powerful 2,000W motor for fast cutting**  
Motor berkuasa 2,000W untuk pemotongan pantas  
功能强大的2,000W马达快速切割

**Standard Equipment:** Carbide-Tipped Saw Blade, Rip Fence, Miter Gauge, Wrenches, Push Stick, Ring



<b>Max Cutting Capacity</b> Kapasiti Pemotongan Maksimum 最大切割能力	90°: 85mm (3-3/8") 45°: 58mm (2-1/4")
<b>Blade Diameter</b> Diameter Bilah 锯片直径	315mm (12-3/8")
<b>No Load Speed (RPM)</b> Kelajuan Tanpa Beban 回转速数	50Hz: 2,950 60Hz: 3,400
<b>Bevel Capacity</b> Kapasiti Bevel 斜角容量	0° - 45°
<b>Dimensions (L x W x H)</b> Dimensi 体积	1,670x700x810mm (65-3/4"x27-1/2"x32")
<b>Net weight</b> Berat Bersih 净重	54kg (118.9lbs)
<b>Power supply cord</b> Kabel Wayar 电源线	3.0m (9.8ft)

## HS6100 165mm (6-1/2")

174 

### Circular Saw

Gergaji Piring  
圆锯



- **Smooth cutting at high rotational speed**  
Pemotongan licin pada kelajuan putaran tinggi  
在高转速下平滑切割

**Standard Equipment:** Carbide-Tipped Saw Blade (B-02917), Hex Wrench, Rip Fence (Guide Rule), Dust Nozzle (195801-0)



<b>Continuous Rating Input</b> Input Kuasa Berterusan 额定输入功率	1,100W
<b>Blade Diameter</b> Diameter Bilah 锯片直径	165mm (6-1/2")
<b>Max Cutting Capacity</b> Kapasiti Pemotongan Maksimum 最大切割能力	90°: 54.5mm (2-1/8")/ 45°: 39.5mm (1-9/16")/ 50°: 35.5mm (1-3/8") 5,500
<b>No Load Speed (RPM)</b> Kelajuan Tanpa Beban 回转速数	297x246x246mm (11-3/4"x9-11/16"x9-11/16")
<b>Dimensions (L x W x H)</b> Dimensi 体积	3.5kg (7.7lbs)
<b>Net Weight</b> Berat Bersih 净重	2.5m (8.2ft)
<b>Power Supply Cord</b> Kabel Wayar 电源线	

Cordless  
Tangkas Kuasa Li-ion

LED Flashlight  
Lampu Suhu LED  
LED 照明灯

Vacuum Cleaner  
Pembersih Vakuum  
吸尘器

Drilling | Fastening  
Operasi | Pasang  
钻孔 | 紧固

Impact Drilling | Demolition  
Drill | Pemasangan  
钻孔 | 拆除加工

Cutting  
Pemotongan  
切割

Grinding | Sanding  
Pengamiran | Tergosok  
打磨 | 磨光

Sawing  
Gergaji  
锯切

Planing | Routing  
Pengamiran | Tergosok  
刨削 | 磨削

Others  
Lain-lain  
其他

Outdoor Power Equipment  
Alat-alat Kuasa Luar  
园林/户外



# SAWING

## HS6600 165mm (6-1/2")

303

### Circular Saw Gergaji Piring 圆锯



- **More compact and lightweight design**  
Reka bentuk lebih padat dan ringan  
更小巧轻便的设计

**Standard Equipment:** Rip Fence (Guide Rule),  
TCT Saw Blade (B-02917), Hex Wrench



<b>Continuous Rating Input</b> Input Kuasa Berterusan 额定输入功率	1,050W
<b>Blade Diameter</b> Diameter Bilah 锯片直径	165mm (6-1/2")
<b>Max Cutting Capacity</b> Kapasiti Pemotongan Maksimum 最大切割能力	90°: 54.5mm (2-1/8") 45°: 37.5mm (1-1/2")
<b>No Load Speed (RPM)</b> Kelajuan Tanpa Beban 回转数	5,200
<b>Dimensions (L x W x H)</b> Dimensi 体积	296x230x243mm (11-5/8"x9"x9-9/16")
<b>Net Weight</b> Berat Bersih 净重	3.5kg (7.6lbs)
<b>Power Supply Cord</b> Kabel Wayar 电源线	2.5m (8.2ft)

## HS7010 185mm (7-1/4") / 190mm (7-1/2")

### Circular Saw Gergaji Piring 圆锯



- **High Power and Increased Motor-Burnout Resistance**  
Berkuasa Tinggi  
高功率

**Standard Equipment:** TCT Saw Blade, Rip Fence (Guide Rule),  
Hex Wrench



<b>Continuous Rating Input</b> Input Kuasa Berterusan 额定输入功率	1,600W
<b>Blade Diameter</b> Diameter Bilah 锯片直径	185/ 190mm (7-1/4"/ 7-1/2")
<b>Max Cutting Capacity</b> Kapasiti Pemotongan Maksimum 最大切割能力	90°: 65/ 67mm (2-9/16"/ 2-5/8") 45°: 44/ 45mm (1-3/4"/ 1-3/4")
<b>No Load Speed (RPM)</b> Kelajuan Tanpa Beban 回转数	5,500
<b>Dimensions (L x W x H)</b> Dimensi 体积	300x240x261mm (11-3/4"x9-1/2"x10-1/4")
<b>Net Weight</b> Berat Bersih 净重	4.0kg (8.9lbs)
<b>Power Supply Cord</b> Kabel Wayar 电源线	2.5m (8.2ft)

## HS7600 185mm (7-1/4")

303

### Circular Saw Gergaji Piring 圆锯



- **Powerful 1,200W motor**  
Motor berkuasa 1,200W  
强力1,200W马达

**Standard Equipment:** TCT Saw Blade, Rip Fence (Guide Rule),  
Hex Wrench



<b>Continuous Rating Input</b> Input Kuasa Berterusan 额定输入功率	1,200W
<b>Blade Diameter</b> Diameter Bilah 锯片直径	185mm (7-1/4")
<b>Max Cutting Capacity</b> Kapasiti Pemotongan Maksimum 最大切割能力	90°: 64mm (2-1/2") 45°: 42mm (1-5/8")
<b>No Load Speed (RPM)</b> Kelajuan Tanpa Beban 回转数	5,200
<b>Dimensions (L x W x H)</b> Dimensi 体积	309x234x255mm (12-1/8"x9-1/4"x10")
<b>Net Weight</b> Berat Bersih 净重	3.8kg (8.3lbs)
<b>Power Supply Cord</b> Kabel Wayar 电源线	2.5m (8.2ft)

## 5806B 185mm (7-1/4")

303

### Circular Saw Gergaji Piring 圆锯



- **Powerful motor for smooth operation even in heavy duty cutting**  
Motor berkuasa untuk operasi lancar walaupun dalam pemotongan tugas berat  
强大的马达即使在重型切割中也可以平稳运行

**Standard Equipment:** Carbide-Tipped Saw Blade, Hex Wrench,  
Rip Fence (Guide Rule)



<b>Continuous Rating Input</b> Input Kuasa Berterusan 额定输入功率	1,050W
<b>Blade Diameter</b> Diameter Bilah 锯片直径	185mm (7-1/4")
<b>Max Cutting Capacity</b> Kapasiti Pemotongan Maksimum 最大切割能力	90°: 66mm (2-5/8") 45°: 44mm (1-11/16")
<b>No Load Speed (RPM)</b> Kelajuan Tanpa Beban 回转数	5,200
<b>Overall Length</b> Panjang Keseluruhan 总长度	282mm (11-1/8")
<b>Net Weight</b> Berat Bersih 净重	3.5kg (7.6lbs)
<b>Power Supply Cord</b> Kabel Wayar 电源线	2.5m (8.2ft)

## 5008MG 210mm (8-1/4")

153

### Circular Saw Gergaji Piring 圆锯



- **Powerful 1,800W motor for proven performance**  
Motor berkuasa 1,800W untuk prestasi yang terbukti  
功率强大的1,800W马达, 性能可靠

**Standard Equipment:** TCT Saw Blade (D-29066), Hex Wrench,  
Rip Fence (Guide Rule)



<b>Continuous Rating Input</b> Input Kuasa Berterusan 额定输入功率	1,800W
<b>Blade Diameter</b> Diameter Bilah 锯片直径	210mm (8-1/4")
<b>Max Cutting Capacity</b> Kapasiti Pemotongan Maksimum 最大切割能力	90°: 75.5mm (3") 45°: 57mm (2-1/4") 50°: 51.5mm (2")
<b>No Load Speed (RPM)</b> Kelajuan Tanpa Beban 回转数	5,200
<b>Dimensions (L x W x H)</b> Dimensi 体积	332x243x277mm (13-1/8"x9-9/16"x10-7/8")
<b>Net Weight</b> Berat Bersih 净重	4.8kg (10.6lbs)
<b>Power Supply Cord</b> Kabel Wayar 电源线	2.5m (8.2ft)

Cordless  
Tenggakord 30.6V

LED Flashlight  
Lampu Suhu LED  
LED照灯

Vacuum Cleaner  
Penarikdebu Vacuum  
吸尘器

Drilling / Fastening  
Cairul / Pengikat  
钻孔 / 紧固

Impact Drilling / Demolition  
Cairul / Penanggal  
钻孔/ 拆除

Cutting  
Pemotong  
切割

Grinding / Sanding  
Pengkilan / Pasir  
打磨 / 砂磨

Sawing  
Cairul  
锯切

Planing / Routing  
Polir / Tinggapan  
刨削 / 雕刻

Others  
Lain-lain  
其他

Outdoor Power Equipment  
Alatan Kerpaja Luar  
园机/户外

Makita  
MAKITA

# SAWING

Cordless  
Tangan Keras 电动式

LED Flashlight  
Lampu Suhu LED  
LED 照明灯

Vacuum Cleaner  
Pembersih Vakum  
吸尘器

Drilling | Fastening  
Operasi | Pengikat  
钻孔 | 紧固

Impact Drilling | Demolition  
Drilling | Pemecah  
冲击钻孔 | 拆除加工

Cutting  
Pemotongan  
切割

Grinding | Sanding  
Pengkilan | Habis  
打磨 | 磨光

Sawing  
Gergaji  
锯切

Planing | Routing  
Pengaliran | Rangkaian  
刨削 | 雕刻

Others  
Lain-lain  
其他

Outdoor Power Equipment  
Alat-alat Tenaga Luar  
园具 / 户外

Makita  
makita

## N5900B 235mm (9-1/4")

153 W

### Circular Saw

Gergaji Piring  
圆锯



- High power 2,000W to rip through most materials  
Kuasai tinggi 2,000W untuk pemotongan pelbagai bahan  
大功率2000W可以切割大部分材料

Standard Equipment: Carbide-Tipped Saw Blade,  
Rip Fence (Guide Rule), Wrench 13



<b>Continuous Rating Input</b> Input Kuasa Berterusan 额定输入功率	2,000W
<b>Max Cutting Capacity</b> Kapasiti Pemotongan Maksimum 最大切割能力	90°: 85mm (3-3/8") 45°: 60mm (2-3/8") 50°: 53mm (2-1/16")
<b>Blade Diameter</b> Diameter Bilah 锯片直径	235mm (9-1/4")
<b>No Load Speed (RPM)</b> Kelajuan Tanpa Beban 回转数	4,100
<b>Overall Length</b> Panjang Keseluruhan 总长度	380mm (15")
<b>Net Weight</b> Berat Bersih 净重	6.8kg (14.8lbs)
<b>Power Supply Cord</b> Kabel Wayar 电源线	2.5m (8.2ft)

## HS0600 260mm (10-1/4")/ 270mm (10-5/8")

153 W

### Circular Saw

Gergaji Piring  
圆锯



- Powerful 2,100W motor  
Motor berkuasa 2,100W  
动力2,100W马达

Standard Equipment: TCT Saw Blade, Rip Fence (Guide Rule),  
Hex Wrench



<b>Continuous Rating Input</b> Input Kuasa Berterusan 额定输入功率	2,000W
<b>Blade Diameter</b> Diameter Bilah 锯片直径	260/ 270mm (10-1/4" / 10-5/8")
<b>Max Cutting Capacity</b> Kapasiti Pemotongan Maksimum 最大切割能力	90°: 97/ 101mm (3-13/16" / 4") 45°: 68/ 71mm (2-11/16" / 2-13/16") 50°: 61/ 63mm (2-3/8" / 2-1/2")
<b>No Load Speed (RPM)</b> Kelajuan Tanpa Beban 回转数	4,300
<b>Dimensions (L x W x H)</b> Dimensi 体积	418x273x324mm (16-1/2"x10-3/4"x12-3/4")
<b>Net Weight</b> Berat Bersih 净重	6.9kg (15.2lbs)
<b>Power Supply Cord</b> Kabel Wayar 电源线	2.5m (8.2ft)

## 5103N 335mm (13-1/8")

153 W

### Circular Saw

Gergaji Piring  
圆锯



- Smooth cutting at high rotational speed  
Pemotongan licin pada kelajuan putaran tinggi  
在高转速下平滑切割

Standard Equipment: Wrench, Rip Fence (Guide Rule)

<b>Continuous Rating Input</b> Input Kuasa Berterusan 额定输入功率	1,750W
<b>Blade Diameter</b> Diameter Bilah 锯片直径	335mm (13-1/8")
<b>Max Cutting Capacity</b> Kapasiti Pemotongan Maksimum 最大切割能力	90°: 128mm (5") 45°: 91mm (3-5/8")
<b>No Load Speed (RPM)</b> Kelajuan Tanpa Beban 回转数	2,900
<b>Overall Length</b> Panjang Keseluruhan 总长度	505mm (19-7/8")
<b>Net Weight</b> Berat Bersih 净重	8.9kg (19.6lbs)
<b>Power Supply Cord</b> Kabel Wayar 电源线	5.0m (16.4ft)

## 5402 415mm (16-5/16")

153 W

### Circular Saw

Gergaji Piring  
圆锯



- Smooth cutting at high rotational speed  
Pemotongan licin pada kelajuan putaran tinggi  
在高转速下平滑切割

Standard Equipment: Combination Saw Blade, Hex Wrench,  
Rip Fence (Guide Rule)

<b>Blade Diameter</b> Diameter Bilah 锯片直径	415mm (16-5/16")
<b>Max Cutting Capacity</b> Kapasiti Pemotongan Maksimum 最大切割能力	90°: 157mm (6-3/16") 45°: 106mm (4-3/16")
<b>No Load Speed (RPM)</b> Kelajuan Tanpa Beban 回转数	2,200
<b>Overall Length</b> Panjang Keseluruhan 总长度	615mm (24-1/4")
<b>Net Weight</b> Berat Bersih 净重	12.9kg (28.4lbs)
<b>Power Supply Cord</b> Kabel Wayar 电源线	5.0m (16.4ft)

## SP6000J 165mm (6-1/2")

303 W

### Plunge Cut Circular Saw

Gergaji Piring  
圆锯



- Built-in current limiter helps prevent motor burnout  
Pengehad arus terbina dalam mencegah motor dari terbakar  
电流限制器有助于防止马达烧毁

Standard Equipment: TCT Saw Blade (B-07353), Hex Wrench

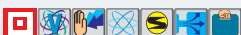

<b>Continuous Rating Input</b> Input Kuasa Berterusan 额定输入功率	1,300W
<b>Blade Diameter</b> Diameter Bilah 锯片直径	165mm (6-1/2")
<b>Max Cutting Capacity</b> Kapasiti Pemotongan Maksimum 最大切割能力	90°: 56mm (2-3/16") 45°: 40mm (1-9/16") 48°: 38mm (1-1/2")
<b>No Load Speed (RPM)</b> Kelajuan Tanpa Beban 回转数	2,000 - 5,800
<b>Dimensions (L x W x H)</b> Dimensi 体积	341x225x250mm (13-3/8"x8-7/8"x9-7/8")
<b>Net Weight</b> Berat Bersih 净重	4.1kg (9lbs)
<b>Power Supply Cord</b> Kabel Wayar 电源线	2.5m (8.2ft)



# SAWING



4329

## Jig Saw

Gergaji Jig  
线锯机



- **Bevel cuts to 45° right or left and positive stop at 90° for solid cutting performance**  
Kelajuan tinggi dan kecekapan tinggi  
高速与高效率



<b>Continuous Rating Input</b> Input Kuasa Berterusan 额定输入功率	450W
<b>Max Cutting Capacity at 90°</b> Kapasti Pemotongan Maksimum 最大切割能力	Wood: 65 mm (2-9/16") Steel: 6 mm (1/4")
<b>Length of Stroke</b> Panjang Strok 冲程长度	18 mm (11/16")
<b>Strokes Per Minute (SPM)</b> Kelajuan Strok 冲程速度	500 - 3,100
<b>Dimensions (L x W x H)</b> Dimensi 体积	223x77x197mm (8-3/4"x3"x7-3/4")
<b>Net Weight</b> Berat Bersih 净重	1.9kg (4.2lbs.)
<b>Power Supply Cord</b> Kabel Wayar 电源线	2.0m (6.6ft)

Standard Equipment: Jig Saw Blade (B-10), Hex Wrench



4350CT

## Jig Saw

Gergaji Jig  
线锯机



- **3 orbital settings plus straight cutting with a powerful 720W motor**  
3 tetapan orbital serta pemotongan lurus dengan motor berkuasa 720W  
强大的720W马达。3个轨道设置与直切割



<b>Continuous Rating Input</b> Input Kuasa Berterusan 额定输入功率	720W
<b>Capacity</b> Kapasti 能力	Wood: 135mm (5-5/16") Steel: 10mm (3/8")
<b>Length of Stroke</b> Panjang Strok 冲程长度	26mm (1")
<b>Strokes Per Minute (SPM)</b> Kelajuan Strok 冲程速度	800 - 2,800
<b>Dimensions (L x W x H)</b> Dimensi 体积	236x73x207mm (9-1/4"x 2-7/8"x 8-1/8")
<b>Net Weight</b> Berat Bersih 净重	2.7kg (5.8lbs)
<b>Power Supply Cord</b> Kabel Wayar 电源线	2.5m (8.2ft)

Standard Equipment: Hex Wrench, Cover Plate, Anti-Splintering Device, Jig Saw Blade Set (No. B-10, BR-13, B-22, 2pcs each)



4351CT

## Jig Saw

Gergaji Jig  
线锯机



- **Bevel cuts to 45° right or left and positive stop at 90° for solid cutting performance**  
Potongan serong ke 45° kanan atau kiri dan berhenti positif pada 90° untuk prestasi pemotongan pepejal  
斜面切割45°左右，90°正向切割，切削性能稳定



<b>Continuous Rating Input</b> Input Kuasa Berterusan 额定输入功率	720W
<b>Capacity</b> Kapasti 能力	Wood: 135mm (5-5/16") Steel: 10mm (3/8")
<b>Length of Stroke</b> Panjang Strok 冲程长度	26 mm (1")
<b>Strokes Per Minute (SPM)</b> Kelajuan Strok 冲程速度	800 - 2,800
<b>Dimensions (L x W x H)</b> Dimensi 体积	271x73x187mm (10-11/16"x 2-7/8"x 7-3/8")
<b>Net Weight</b> Berat Bersih 净重	2.6kg (5.7lbs)
<b>Power Supply Cord</b> Kabel Wayar 电源线	2.5m (8.2ft)

Standard Equipment: Hex Wrench, Cover Plate, Anti-Splintering Device, Jig Saw Blade Set (No. B-10, BR-13, B-22, 2pcs each)



JV600K

## Jig Saw

Gergaji Jig  
线锯机



- **Toolless blade change system for fast blade installation and removal**  
Penukaran bilah tanpa alat untuk pemasangan bilah cepat  
无需工具更换刀片，可快速安装和拆卸刀片



<b>Continuous Rating Input</b> Input Kuasa Berterusan 额定输入功率	650W
<b>Capacity</b> Kapasti 能力	Wood: 90mm (3-1/2") Steel: 10mm (3/8")
<b>Length of Stroke</b> Panjang Strok 冲程长度	23mm (7/8")
<b>Strokes Per Minute (SPM)</b> Kelajuan Strok 冲程速度	500 - 3,100
<b>Dimensions (L x W x H)</b> Dimensi 体积	236x77x199mm (9-1/4"x3"x7-7/8")
<b>Net Weight</b> Berat Bersih 净重	2.4kg (5.3lbs)
<b>Power Supply Cord</b> Kabel Wayar 电源线	2.5m (8.2ft)

Standard Equipment: Jig Saw Blade, Hex Wrench



Cordless  
Terdapat 30.0.0.0.0.

LED Flashlight  
Lampu Suluh LED  
LED 30.0.0.0.0.

Vacuum Cleaner  
Penyedut Vakuum  
30.0.0.0.0.

Drilling / Fastening  
Gergaji / Pengikat  
30.0.0.0.0.

Impact Drilling / Demolition  
Gergaji / Pemecah  
30.0.0.0.0.

Cutting  
Pemotong  
30.0.0.0.0.

Grinding / Sanding  
Pengkilan / Pasir  
30.0.0.0.0.

Sawing  
Gergaji  
30.0.0.0.0.

Planing / Routing  
Polishan / Tinggikan  
30.0.0.0.0.

Others  
Lain-lain  
30.0.0.0.0.

Outdoor Power Equipment  
Alatan Kuasa Luar  
30.0.0.0.0.

Makita  
30.0.0.0.0.

# SAWING

## 4327M

64

### Jig Saw

Gergaji Jig  
线锯机



- **High power and Lightweight**  
Kuasai tinggi dan Ringan  
高功率和轻量

Standard Equipment: Jig Saw Blade, Hex Wrench



<b>Continuous Rating Input</b> Input Kuasa Berterusan 额定输入功率	450W
<b>Capacity</b> Kapasiti 能力	Wood: 40mm (1-9/16") Steel: 6mm (1/4")
<b>Length of Stroke</b> Panjang Strok 冲程长度	18mm (11/16")
<b>Strokes Per Minute (SPM)</b> Kelajuan Strok 冲程速度	500 - 3,100
<b>Dimensions (L x W x H)</b> Dimensi 体积	224x77x197mm (8-7/8"x3"x7-3/4")
<b>Net Weight</b> Berat Bersih 净重	1.8kg (4.0lbs)
<b>Power Supply Cord</b> Kabel Wayar 电源线	2.0m (6.6ft)

## 4327

64

### Jig Saw

Gergaji Jig  
线锯机



- **High power and Lightweight**  
Kuasai tinggi dan Ringan  
高功率和轻量

Standard Equipment: Jig Saw Blade, Hex Wrench



<b>Continuous Rating Input</b> Input Kuasa Berterusan 额定输入功率	450W
<b>Capacity</b> Kapasiti 能力	Wood: 65mm (2-9/16") Steel: 6mm (1/4")
<b>Length of Stroke</b> Panjang Strok 冲程长度	18mm (11/16")
<b>Strokes Per Minute (SPM)</b> Kelajuan Strok 冲程速度	500 - 3,100
<b>Dimensions (L x W x H)</b> Dimensi 体积	224x77x197mm (8-7/8"x3"x7-3/4")
<b>Net Weight</b> Berat Bersih 净重	1.9kg (4.2lbs)
<b>Power Supply Cord</b> Kabel Wayar 电源线	2.0m (6.6ft)

## 4300BV

51

### Jig Saw

Gergaji Jig  
线锯机



- **Robust construction and strength to cut through a wide range of materials**  
Pembinaan yang kukuh dengan kekuatan untuk memotong pelbagai bahan  
坚固的结构和强度可切割各种材料

Standard Equipment: Jig saw blade set, Rip Fence (Guide Rule), Circular Guide, Hex Wrench



<b>Continuous Rating Input</b> Input Kuasa Berterusan 额定输入功率	390W
<b>Capacity</b> Kapasiti 能力	Wood: 55mm (2-1/8") Steel: 6mm (1/4")
<b>Length of Stroke</b> Panjang Strok 冲程长度	26mm (1")
<b>Strokes Per Minute (SPM)</b> Kelajuan Strok 冲程速度	0-3,100
<b>Overall Length</b> Panjang Keseluruhan 总长度	225mm (8-7/8")
<b>Net Weight</b> Berat Bersih 净重	2.5kg (5.5lbs)
<b>Power Supply Cord</b> Kabel Wayar 电源线	2.5m (8.2ft)

## JR3050T

303

### Recipro Saw

Gergaji Resipro  
往复锯



- **Ideal for framers, carpenters, electricians, plumbers and general construction**  
Untuk framers, tukang kayu, juruelektrik, tukang paip dan pembinaan umum  
木工、木匠、电工、水管工和一般建筑的理想选择

Standard Equipment: Recipro Saw Blades 3pcs (No. 21, 22, 23)



<b>Continuous Rating Input</b> Input Kuasa Berterusan 额定输入功率	1,010W
<b>Length of Stroke</b> Panjang Strok 冲程长度	28mm (1-1/8")
<b>Strokes Per Minute (SPM)</b> Kelajuan Strok 冲程速度	0 - 2,800
<b>Capacity</b> Kapasiti 能力	Pipe : 130mm (3-1/2") Wood: 255mm (10")
<b>Overall Length</b> Panjang Keseluruhan 总长度	452mm (17-3/4")
<b>Net Weight</b> Berat Bersih 净重	3.3kg (7.3lbs)
<b>Power Supply Cord</b> Kabel Wayar 电源线	2.5m (8.2ft)

## JR3051TK

303

### Recipro Saw

Gergaji Resipro  
往复锯



- **Powerful 1,200W motor for improved performance**  
Meningkatkan prestasi dengan motor 1,200W  
强大的1,200W电机可提高性能

Standard Equipment: Recipro Saw Blades 3pcs (No. 21, 22, 23)



<b>Continuous Rating Input</b> Input Kuasa Berterusan 额定输入功率	1,200W
<b>Length of Stroke</b> Panjang Strok 冲程长度	30mm (1-3/16")
<b>Strokes Per Minute (SPM)</b> Kelajuan Strok 冲程速度	0 - 3,000
<b>Capacity</b> Kapasiti 能力	Pipe: 130mm (5-1/8") Wood: 255mm (10")
<b>Dimensions (L x W x H)</b> Dimensi 体积	447x97x176mm (17-5/8"x3-13/16"x6-15/16")
<b>Net Weight</b> Berat Bersih 净重	3.2 - 3.3kg (7.1 - 7.3lbs.)
<b>Power Supply Cord</b> Kabel Wayar 电源线	2.5m (8.2ft)

**NEW**  
BARU | 新

# SAWING

## JR3070CT

303mm

### Recipro Saw Gergaji Resipro 往复锯



- **Anti-Vibration Technology for 2X Less Vibration**  
Mengurangkan getaran 2X dengan teknologi anti getaran 2倍减振的防振技术



<b>Continuous Rating Input</b> Input Kuasa Berterusan 额定输入功率	1,510W
<b>Length of Stroke</b> Panjang Strok 冲程长度	32mm (1-1/4")
<b>Strokes Per Minute (SPM)</b> Kelajuan Strok 冲程速度	0 - 2,800
<b>Capacity</b> Kapasti 能力	Pipe : 130mm (5-1/8") Wood: 255mm (10")
<b>Overall Length</b> Panjang Keseluruhan 总长度	485mm (19-1/8")
<b>Net Weight</b> Berat Bersih 净重	4.6kg (10lbs)
<b>Power Supply Cord</b> Kabel Wayar 电源线	2.5m (8.2ft)

Standard Equipment: Recipro Saw Blades 3pcs



**AVT**  
ANTI-VIBRATION TECHNOLOGY

## SJ401

### Scroll Saw Gergaji Scroll 平台式线锯机



- **Bevel cuts up to 45° to the left and 15° to the right**  
Pemotongan serong sehingga 45° ke kiri dan 15° ke kanan  
斜角向左切割45°，向右切割15°



<b>Continuous Rating Input</b> Input Kuasa Berterusan 额定输入功率	50W
<b>Capacity</b> Kapasti 能力	Thickness of cut : 50mm (2") Throat : 406mm (16")
<b>Length of Stroke</b> Panjang Strok 冲程长度	18mm (11/16")
<b>Strokes Per Minute (SPM)</b> Kelajuan Strok 冲程速度	400-1,600
<b>Overall Length</b> Panjang Keseluruhan 总长度	600mm (23-5/8")
<b>Net Weight</b> Berat Bersih 净重	14kg (30.87lbs)

Standard Equipment: Saw blade x6, Hex Wrench, Blade Change Rod



## LB1200F

### Band Saw Gergaji Band 带锯



- **High/ low speed selection for excellent results in both hard and soft wood**  
Pemilihan kelajuan tinggi/ rendah untuk kayu keras dan lembut  
高/低速选择，切割硬木和软木



<b>Continuous Rating Input</b> Input Kuasa Berterusan 额定输入功率	900W
<b>Capacity</b> Kapasti 能力	Thickness of cut : 165mm (6-1/2") Throat : 305mm (12")
<b>Blade Speed</b> Kelajuan Bilah 锯片速度	High: (50Hz)800 (60Hz)1,000m (50 Hz)2,624 (60 Hz) 3,280ft/ min Low: (50Hz)400 (60Hz)500m (50Hz)1,312 (60Hz) 1,640ft/ min
<b>Dimensions (L x W x H)</b> Dimensi 体积	615x775x1,600mm (24-1/4"x30-1/2"x63")
<b>Net Weight</b> Berat Bersih 净重	82kg (181.2lbs)
<b>Power Supply Cord</b> Kabel Wayar 电源线	2.5m (8.2ft)

Standard Equipment: Band Saw Blades, Rip Fence, Miter Gauge, Push Stick, Nozzle, Hex Wrench, Band Saw Stand



Cordless  
Tenggakord 30.8ft

LED Flashlight  
Lampu Suhu LED  
LED照灯

Vacuum Cleaner  
Penyerbuk Vacuum  
吸尘器

Drilling / Fastening  
Cairus / Pengikat  
钻孔 / 紧固

Impact Drilling / Demolition  
Cairus / Penusuk  
冲击钻孔 / 拆毁施工

Cutting  
Pemotong  
切割

Grinding / Sanding  
Pengkilan / Pasir  
打磨 / 砂磨

Sawing  
Cergas  
锯切

Planing / Routing  
Pegyalan / Tampam  
刨削 / 雕刻

Others  
Lain-lain  
其他

Outdoor Power Equipment  
Alatan Kerpaja Luar  
园具/户外

**Makita**  
MAKITA

# PLANING ROUTERING

Mengetam | Tanggam 刨削 | 雕刻



## KP0810 82mm (3-1/4")

132 W

### Power Planer

Planer Elektrik  
电刨



- **Powerful & lightweight**  
Berkuasa & ringan  
强力与轻量



**Standard Equipment:** Blade Gauge, Depth Guide, Guide Rule,  
Planer Blade, Socket Wrench



<b>Continuous Rating Input</b> Input Kuasa Berterusan 额定输入功率	850W
<b>Planing Width</b> Lebar Pelan 刨削宽度	82mm (3-1/4")
<b>Planing Depth</b> Kedalaman Pelan 刨削深度	4mm (5/32")
<b>No Load Speed (RPM)</b> Kelajuan Tanpa Beban 回转数	16,000
<b>Dimensions (L x W x H)</b> Dimensi 体积	290x168x176mm (11-3/8"x6-5/8"x6-15/16")
<b>Net Weight</b> Berat Bersih 净重	3.3kg (7.3lbs)
<b>Power Supply Cord</b> Kabel Wayar 电源线	2.5m (8.2ft)

## KP0800X 82mm (3-1/4")

411 W

### Power Planer

Planer Elektrik  
电刨



- **High power & lightweight**  
Kuasa tinggi & ringan  
高功率与轻量



**Standard Equipment:** Planer Blade, Blade Gauge, Guide Rule,  
Socket Wrench, Dust Nozzle



<b>Continuous Rating Input</b> Input Kuasa Berterusan 额定输入功率	620W
<b>Planing Width</b> Lebar Pelan 刨削宽度	82mm (3-1/4")
<b>Planing Depth</b> Kedalaman Pelan 刨削深度	2.5mm (3/32")
<b>No Load Speed (RPM)</b> Kelajuan Tanpa Beban 回转数	17,000
<b>Dimensions (L x W x H)</b> Dimensi 体积	285x158x158mm (11-1/4"x6-1/4"x6-1/4")
<b>Net Weight</b> Berat Bersih 净重	2.8kg (6.2lbs)
<b>Power Supply Cord</b> Kabel Wayar 电源线	2.5m (8.2ft)

## N1900B 82mm (3-1/4")

51 W

### Power Planer

Planer Elektrik  
电刨



- **V-groove on base for easy chamfer cutting**  
V-groove pada dasar untuk pemotongan melencong mudah  
底座上的V型槽，便于倒角切割



**Standard Equipment:** Sharpening Holder Assembly,  
Blade Gauge, Socket Wrench, Planer Blade, Guide Rule



<b>Continuous Rating Input</b> Input Kuasa Berterusan 额定输入功率	580W
<b>Planing Width</b> Lebar Pelan 刨削宽度	82mm (3-1/4")
<b>Planing Depth</b> Kedalaman Pelan 刨削深度	1mm (1/32")
<b>No Load Speed (RPM)</b> Kelajuan Tanpa Beban 回转数	16,000
<b>Overall Length</b> Panjang Keseluruhan 总长度	290mm (11-3/8")
<b>Net Weight</b> Berat Bersih 净重	2.8kg (6.1lbs)
<b>Power Supply Cord</b> Kabel Wayar 电源线	2.5m (8.2ft)

## 1911B 110mm (4-3/8")

106 W

### Power Planer

Planer Elektrik  
电刨



- **Powerful motor in compact and lightweight body**  
Motor berkuasa badan padat dan ringan  
马达功能强大，体积小巧轻便



**Standard Equipment:** Sharpening Holder Assembly, Blade  
Gauge, Socket Wrench, Planer Blade



<b>Continuous Rating Input</b> Input Kuasa Berterusan 额定输入功率	840W
<b>Planing Width</b> Lebar Pelan 刨削宽度	110mm (4-3/8")
<b>Planing Depth</b> Kedalaman Pelan 刨削深度	2mm (1/16")
<b>No Load Speed (RPM)</b> Kelajuan Tanpa Beban 回转数	16,000
<b>Overall Length</b> Panjang Keseluruhan 总长度	355mm (14")
<b>Net Weight</b> Berat Bersih 净重	4.1kg (9.1lbs)
<b>Power Supply Cord</b> Kabel Wayar 电源线	5.0m (16.4ft)

Cordless  
Tanpa Kabel / 无线式

LED Flashlight  
Lampu Suluh LED  
(LED 照明灯)

Vacuum Cleaner  
Pembersih Vakuum  
(吸尘器)

Drilling / Fastening  
Ganda / Pengikat  
(钻孔 / 紧固)

Impact Drilling / Demolition  
Ganda / Penembak  
(冲击钻孔 / 拆墙加工)

Cutting  
Pemotongan  
(切割)

Grinding / Sanding  
Pengkilan / Pasir  
(打磨 / 砂磨)

Sawing  
Ganda  
(锯切)

Planing / Routing  
Pengaliran / Tanggam  
(刨削 / 雕刻)

Others  
Lain-lain  
(其他)

Outdoor Power Equipment  
Alatan Kuasa Luar  
(户外动力设备)

Makita  
Makita

# PLANING | ROUTERING

## 1805N 155mm (6-1/8")

153

### Power Planer

Planer Elektrik  
电刨



- **Rugged aluminum housing and easy depth settings**  
Casing aluminium yang lasak dan penetapan kedalaman yang mudah  
坚固的铝外壳和简单的深度设置

**Standard Equipment:** Sharpening Holder Assembly, Blade Gauge, Socket Wrench, Planer Blade



<b>Continuous Rating Input</b> Input Kuasa Berterusan 额定输入功率	1,140W
<b>Planing Width</b> Lebar Pelan 刨削宽度	155mm (6-1/8")
<b>Planing Depth</b> Kedalaman Pelan 刨削深度	2mm (1/16")
<b>No Load Speed (RPM)</b> Kelajuan Tanpa Beban 回转数	15,000
<b>Overall Length</b> Panjang Keseluruhan 总长度	445mm (17-1/2")
<b>Net Weight</b> Berat Bersih 净重	7.9kg (17.3lbs)
<b>Power Supply Cord</b> Kabel Wayar 电源线	5.0m (16.4ft)

## 2012NB 304mm (12")

153

### Planer

Planer Elektrik  
电刨



- **Powerful 1,650W motor for improved performance**  
Motor 1,650W yang berkuasa meningkatkan prestasi  
功率强劲的1,650W马达提高了性能

**Standard Equipment:** Socket Wrench, Hex Wrench, Magnetic holder x2



<b>Continuous Rating Input</b> Input Kuasa Berterusan 额定输入功率	1,650W
<b>Cutting Width</b> Lebar Pelan 刨削宽度	304mm (12")
<b>Cutting Depth</b> Kedalaman Pelan 刨削深度	Cutting width 0-150mm: 3mm (1/8") Cutting width 150-240mm : 1.5mm (1/16")
<b>Feed Rate (min)</b> Kadar Suapan 进料速度	8.5m (27.9ft)
<b>Table Size (W x L)</b> Saiz Meja 工作台尺寸	304 x 771mm (12" x 30-3/8")
<b>No Load Speed (RPM)</b> Kelajuan Tanpa Beban 回转数	8,500
<b>Dimensions (L x W x H)</b> Panjang Keseluruhan 总长度	483x771x401mm (19"x30-3/8"x15-13/16")
<b>Net Weight</b> Berat Bersih 净重	27.1 - 27.6kg (59.7 - 60.9lbs)
<b>Power Supply Cord</b> Kabel Wayar 电源线	2.5m (8.2ft)

## 3501N

153

### Groove Cutter

Pemotong alur  
沟锯



- **Powerful motor, easy depth adjustment**  
Motor berkuasa, pelarasan kedalaman yang mudah  
强大的马达，容易调整深度

**Standard Equipment:** Saw Blade (A-87507), Shiplapping Scale, Rip Fence (Guide Rule), Dressing Stone, Wrench x2, Screwdriver, Cutter Blade



<b>Continuous Rating Input</b> Input Kuasa Berterusan 额定输入功率	1,160W
<b>Max Cutter Blade Size</b> Saiz Bilah Maksimum 最大锯片尺寸	Dia. x Width: 120x36mm (4-3/4"x1-3/8")
<b>Max Cutting Depth</b> Kedalaman Pemotongan Maksimum 最大切割深度	Cutter/ Saw: 30mm (1-1/8")/ 65 mm (2-1/2")
<b>No Load Speed (RPM)</b> Kelajuan Tanpa Beban 回转数	6,500
<b>Overall Length</b> Panjang Keseluruhan 总长度	365mm (14-3/8")
<b>Net Weight</b> Berat Bersih 净重	7.2kg (15.8lbs)
<b>Power Supply Cord</b> Kabel Wayar 电源线	5.0m (16.4ft)

## PJ7000

459

### Plate Joiner

Mesin Kerja Kayu  
木工接合机



- **Large and easy-to-operate cam locks for fence adjustments**  
Pelarasan pagar yang mudah  
简易栅栏调节

**Standard Equipment:** Cutter Blade, Angle Guide, Dust Bag, Set Plate, Lock Nut Wrench



<b>Continuous Rating Input</b> Input Kuasa Berterusan 额定输入功率	701W
<b>Blade Diameter</b> Diameter Bilah 锯片直径	100mm (4")
<b>No Load Speed (RPM)</b> Kelajuan Tanpa Beban 回转数	11,000
<b>Dimensions (L x W x H)</b> Dimensi 体积	302x139x145mm (11-7/8"x5-1/2"x5-3/4")
<b>Net Weight</b> Berat Bersih 净重	2.8kg (6.2lbs)
<b>Power Supply Cord</b> Kabel Wayar 电源线	2.5m (8.2ft)



Cordless  
Tetapan Aord 10.8V

LED Flashlight  
Lampu Suluh LED  
LED081802

Vacuum Cleaner  
Penembuh Vakuam  
02031

Drilling / Fastening  
Garu / Pasang  
0211 / 0212

Impact Drilling / Demolition  
Garu / Penembok  
0213 / 0214

Impact Drilling / Demolition  
Garu / Penembok  
0213 / 0214

Cutting  
Pemotong  
0215

Grinding / Sanding  
Pengiraan / Pasah  
0216 / 0217

Sawing  
Garu  
0218

Planing / Routing  
Pagar / Tuangkan  
0219 / 0220

Others  
Lain-lain  
0221

Outdoor Power Equipment  
Alatan Kerja Luar  
0222 / 0223

Makita  
MAKITA

# PLANING | ROUTERING

3901

411

## Plate Joiner

Mesin Kerja Kayu  
木工接合机



- **Designed for making strong plate joints fast**  
Direka untuk penyambungan rata  
用于快速制作坚固的平板接头

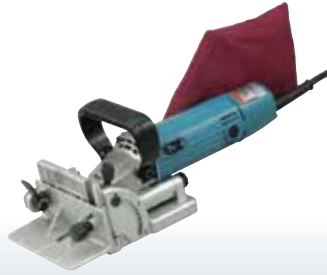

**Standard Equipment:** Cutter Blade, Angle Guide, Dust Bag, Set Plate, Lock Nut Wrench



<b>Continuous Rating Input</b> Input Kuasa Berterusan 额定输入功率	590W
<b>Blade Diameter</b> Diameter Bilah 锯片直径	100mm (4")
<b>Max Cutting Depth</b> Kedalaman Pemotongan Maksimum 最大切割深度	20mm (3/4")
<b>No Load Speed (RPM)</b> Kelajuan Tanpa Beban 回转数	11,000
<b>Overall Length</b> Panjang Keseluruhan 总长度	307mm (12-1/16")
<b>Net Weight</b> Berat Bersih 净重	3.0kg (6.6lbs)
<b>Power Supply Cord</b> Kabel Wayar 电源线	2.5m (8.2ft)

RT0700C / X2 6mm (1/4"), 8mm (3/8")

411

## Trimmer

Pemangkas  
修边雕刻机



- **Powerful 710W motor for improved performance**  
Motor berkuasa 710W untuk prestasi yang lebih baik  
强大710W马达提高了性能



For RT0700X2 only



**Standard Equipment:**

RT0700C: Collet Cone, Trimmer Base Assembly, Straight Guide, Dust Nozzle, Wrench x2

RT0700X2: Collet Cone, Trimmer Base Assembly, Straight Guide, Dust Nozzle, Wrench x2, Side Grip, Templet Guide, Tilt Base Assembly, Plunge Base Assembly, Tool Bag



<b>Continuous Rating Input</b> Input Kuasa Berterusan 额定输入功率	710W
<b>Collet Capacity</b> Kapasiti Collet 夹头直径	6mm, 8mm or 1/4", 3/8"
<b>No Load Speed (RPM)</b> Kelajuan Tanpa Beban 回转数	10,000 - 30,000
<b>Dimensions (L x W x H)</b> Dimensi 体积	89x89x200mm (3-1/2"x3-1/2"x7-7/8")
<b>Net Weight</b> Berat Bersih 净重	1.8 - 2.7kg (3.9 - 6.0lbs)
<b>Power Supply Cord</b> Kabel Wayar 电源线	2.5m (8.2ft)

3709 6mm (1/4")

411

## Trimmer

Pemangkas  
修边雕刻机

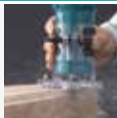

- **530W motor for smooth trimming**  
530W motor untuk pemangkas yang licin  
530W马达提供平滑的修剪



**Standard Equipment:** Collet Cone, Trimmer Guide, Straight Guide Assembly, Templet Guide, Straight Bit, Chip Deflector, Wrench x2



<b>Continuous Rating Input</b> Input Kuasa Berterusan 额定输入功率	530W
<b>Collet Capacity</b> Kapasiti Collet 夹头直径	6mm or 1/4"
<b>No Load Speed (RPM)</b> Kelajuan Tanpa Beban 回转数	30,000
<b>Dimensions (L x W x H)</b> Dimensi 体积	82x90x199mm (3-1/4"x3-1/2"x7-7/8")
<b>Net Weight</b> Berat Bersih 净重	1.5kg (3.3lbs)
<b>Power Supply Cord</b> Kabel Wayar 电源线	2.5m (8.2ft)

RP0900 6mm (1/4"), 8mm (3/8")

106

## Router (Plunge type)

Pemangkas  
雕刻机



- **Oversized ball bearing construction for longer tool life**  
Konstruksi galas bebola untuk memanjangkan hayat alat  
超大滚珠轴承结构, 延长工具寿命



**Standard Equipment:** Straight Guide, Straight Bit, Collet cone x2, Wrenches



<b>Continuous Rating Input</b> Input Kuasa Berterusan 额定输入功率	900W
<b>Collet Capacity</b> Kapasiti Collet 夹头直径	6mm, 8mm or 1/4", 3/8"
<b>Plunge Capacity</b> Kapasiti Plunge 能力	0 - 35mm (0 - 1-3/8")
<b>No Load Speed (RPM)</b> Kelajuan Tanpa Beban 回转数	27,000
<b>Dimensions (L x W x H)</b> Dimensi 体积	110x256x217mm (4-5/16"x10-3/32"x8-17/32")
<b>Net Weight</b> Berat Bersih 净重	2.7kg (6lbs)
<b>Power Supply Cord</b> Kabel Wayar 电源线	2.5m (8.2ft)

RP2301FC 12mm (1/2")

203

## Router (Plunge type)

Pemangkas  
雕刻机



- **Powerful 2,100W motor for the most demanding applications**  
Motor 2,100W berkuasa untuk aplikasi yang paling mencabar  
功能强大2.100W马达, 适用于要求苛刻的应用



**Standard Equipment:** Straight Guide, Collet Cone, Wrench, Screw M6x135, Straight Bit 1/2" (D-07901)

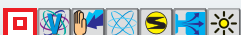

<b>Continuous Rating Input</b> Input Kuasa Berterusan 额定输入功率	2,100W
<b>Collet Capacity</b> Kapasiti Collet 夹头直径	12mm or 1/2"
<b>Plunge Capacity</b> Kapasiti Plunge 能力	0 - 70mm (0 - 2-3/4")
<b>No Load Speed (RPM)</b> Kelajuan Tanpa Beban 回转数	9,000 - 22,000
<b>Dimensions (L x W x H)</b> Dimensi 体积	155x294x312mm (6-1/8"x11-5/8"x12-1/4")
<b>Net Weight</b> Berat Bersih 净重	6.1kg (13.5lbs)
<b>Power Supply Cord</b> Kabel Wayar 电源线	4.0m (13.1ft)

Cordless  
Tangkas Hood 无线式LED Flashlight  
Lampu Suluh LED  
LED 照明灯Vacuum Cleaner  
Pembersih Vakuum  
吸尘器Drilling / Fastening  
Ganda / Pengikat  
钻孔 / 紧固Impact Drilling / Demolition  
Ganda / Penembak  
起工钻孔 / 拆毁加工Cutting / Planing  
Pemotong  
切割Grinding / Sanding  
Pengisar / Palsin  
打磨 / 砂磨Sawing  
Ganda  
锯切Planing / Routing  
Pengaliran / Tangkas  
刨削 / 雕刻Others  
Lain-lain  
其他Outdoor Power Equipment  
Alatan Kerja Luar  
园具-户外Makita  
MAKITA

# PLANING | ROUTERING

## RP1801 12mm (1/2")

203

### Router (Plunge type)

Pemangkas  
雕刻机



- **Electric brake for increased operator safety**  
Brake elektrik untuk pengguna keselamatan  
电子自动刹车

**Standard Equipment:** Straight Guide, Collet Cone, Wrench,  
Screw M6x135, Template Guide



<b>Continuous Rating Input</b> Input Kuasa Berterusan 额定输入功率	1,650W
<b>Collet Capacity</b> Kapasiti Collet 夹头直径	12mm or 1/2"
<b>Plunge Capacity</b> Kapasiti Plunge 能力	0 - 70mm (0 - 2-3/4")
<b>Base Dia.</b> Diameter Pangkalan 底座直径	170mm (6-11/16")
<b>No Load Speed (RPM)</b> Kelajuan Tanpa Beban 回转数	22,000
<b>Dimensions (L x W x H)</b> Dimensi 体积	155x294x312mm (6-1/8"x11-5/8"x12-1/4")
<b>Net Weight</b> Berat Bersih 净重	6kg (13.2lbs)
<b>Power Supply Cord</b> Kabel Wayar 电源线	4.0m (13.1ft.)

## 3612BR 12mm (1/2")

153

### Router (Plunge type)

Pemangkas  
雕刻机

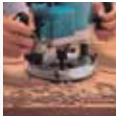

- **Conveniently located plunge lock lever for efficient operation**  
Pelarasan tool yang mudah untuk operasi yang cekap  
便利的插入式锁定杆可实现高效操作

**Standard Equipment:** Straight Guide, Templet Guide, Trimmer Guide,  
Guide Holder, Collet Sleeve (6mm or 1/4"), Collet Sleeve (8mm or 3/8"),  
Straight Bit (Carbide-Tipped) D-07901, Wrench



<b>Continuous Rating Input</b> Input Kuasa Berterusan 额定输入功率	1,600W
<b>Collet Capacity</b> Kapasiti Collet 夹头直径	12mm or 1/2"
<b>Plunge Capacity</b> Kapasiti Plunge 能力	0 - 65mm (0 - 2-9/16")
<b>No Load Speed (RPM)</b> Kelajuan Tanpa Beban 回转数	23,000
<b>Dimensions (L x W x H)</b> Dimensi 体积	160x276x287mm (6-5/16"x10-7/8"x11-5/16")
<b>Net Weight</b> Berat Bersih 净重	5.5kg (12.1lbs)
<b>Power Supply Cord</b> Kabel Wayar 电源线	2.5m (8.2ft.)



## 3600H 12mm (1/2")

153

### Router

Pemangkas  
雕刻机



- **D-handle design with locking trigger switch for comfort during continuous operation**  
Pemegang-D dengan suis pencetus berkunci untuk keselesaan  
semasa operasi berterusan  
带锁定扳机开关的D型手柄设计可确保连续操作时的舒适性

**Standard Equipment:** Trimmer Guide, Straight Guide Assembly,  
Templet Guide, Collet Sleeve (6mm or 1/4"), Collet Sleeve (8mm or 3/8"),  
Wrench, Straight Bit (Carbide-Tipped) D-07901

<b>Continuous Rating Input</b> Input Kuasa Berterusan 额定输入功率	1,500W
<b>Collet Capacity</b> Kapasiti Collet 夹头直径	12mm or 1/2"
<b>Base Dia.</b> Diameter Pangkalan 底座直径	160mm (6-1/4")
<b>No Load Speed (RPM)</b> Kelajuan Tanpa Beban 回转数	24,000
<b>Overall Height</b> Panjang Keseluruhan 总长度	210mm (8-1/4")
<b>Net Weight</b> Berat Bersih 净重	4.4kg (9.8lbs)
<b>Power Supply Cord</b> Kabel Wayar 电源线	5.0m (16.4ft)

## 4403 6mm (1/4")

411

### Sash Router

Pemangkas Sash  
窗扇雕刻机



- **Large transparent chip guard for operator's safety**  
Pengawal cip telus yang besar untuk keselamatan pengguna  
大型透明芯片防护罩保证操作者的安全

**Standard Equipment:** Collet cone (6mm or 1/4"),  
Drill Point Sash Router Bit (D-16972), Angle Gauge,  
Wrench x2, Oil supply



<b>Continuous rating input</b> Input Kuasa Berterusan 额定输入功率	530W
<b>Capacity</b> Kapasiti 能力	Collet: 6mm or 1/4"
<b>Max Width of Work</b> Lebar Kerja Maksimum 最大工作宽度	123mm (4-7/8")
<b>Max Width of Work (45°)</b> Lebar Kerja Maksimum 最大工作宽度	77mm (3")
<b>Max Height of Work</b> Ketinggian Kerja Maksimum 最大工作高度	185mm (7-1/4")
<b>No Load Speed (RPM)</b> Kelajuan Tanpa Beban 回转数	30,000
<b>Dimensions (L x W x H)</b> Dimensi 体积	327x350x355mm (12-7/8"x13-13/16"x14")
<b>Net Weight</b> Berat Bersih 净重	16kg (35.3lbs)
<b>Power Supply Cord</b> Kabel Wayar 电源线	2.5m (8.2ft)

**Cordless**  
Tetapan Aord 10.8V

**LED Flashlight**  
Lampu Sulu LED  
LECOB 8002

**Vacuum Cleaner**  
Penembuh Vakuam  
800301

**Drilling | Fastening**  
Cairul | Pengikat  
8001 | 8002

**Impact Drilling | Demolition**  
Cairul - Cairul / Penembuh  
800301 | 800302

**Cutting**  
Pemotong  
8001

**Grinding | Sanding**  
Pengkilan | Palsah  
8001 | 8002

**Sawing**  
Gergaji  
8001

**Planing | Routing**  
Pengkilan | Tunggau  
8001 | 8002

**Others**  
Lain-lain  
8001

**Outdoor Power Equipment**  
Alatan Kertaji Luar  
8001-8002

**Makita**  
1915

Cordless  
Turret Head 无绳式  
转塔式

LED Flashlight  
Lampu Suhu LED  
LED 照明灯

Vacuum Cleaner  
Pembersih Vakum  
吸尘器

Drilling / Fastening  
Ganub / Penekan  
钻孔 / 紧固

Impact Drilling / Demolition  
Ganub / Pemukul  
冲击钻孔 / 拆除加工

Cutting  
Pemotong  
切割

Grinding / Sanding  
Pengamir / Pasir  
打磨 / 砂磨

Sawing  
Gergaji  
锯切

Planing / Routing  
Pengamir / Tengamir  
刨削 / 雕刻

Others  
Lain-lain  
其他

Outdoor Power Equipment  
Alat-alat Listrik  
园林工具

Makita  
Makita

# OTHERS

Lain-lain 其他



## AF506

**Pneumatic Brad Nailer**  
Penembak Paku Brad Pneumatik  
气钉枪



- **Lightweight for reduced operator fatigue**  
Ringan untuk mengurangi kelelahan pengguna  
轻量不易引起疲劳

Standard Equipment: Safety Goggles, Nose Adapter, Oil



<b>Capacity</b> Kapasiti 能力	Length: 15 - 50mm (5/8" - 2")
<b>Operating Pressure</b> Tekanan Beroperasi 使用气压	Gauge: 18Ga 0.49 - 0.83MPa (70 - 120PSI)
<b>Magazine Capacity</b> Bilangan Staples 装订个数	100
<b>Compressed Air</b> Udara Mampat 压缩空气	Driver stroke: 85.5mm (3-3/8") Cylinder bore diameter: 28mm (1-1/8")
<b>Dimensions (L x W x H)</b> Dimensi 体积	250x70x256mm (9-7/8"x2-3/4"x10-1/8")
<b>Net Weight</b> Berat Bersih 净重	1.3kg (2.9lbs.)

Accessories (optional)			
Description	Size	Pcs/ Box	Part No.
Brad Nail 15mm (5/8")	F15	5,000	B-04307
Brad Nail 20mm (3/4")	F20	5,000	B-04313
Brad Nail 25mm (1")	F25	5,000	B-04329
Brad Nail 30mm (1-3/16")	F30	5,000	B-04335
Brad Nail 35mm (1-3/8")	F35	5,000	B-04357

## AF353

**Pneumatic Pin Nailer**  
Mesin Pemaku Pneumatik  
气钉枪



- **Lightweight for reduced operator fatigue**  
Ringan untuk mengurangi kelelahan pengguna  
轻量不易引起疲劳

Standard Equipment: Safety Goggles, Nose Adapter, Hex Wrench, Oil



<b>Capacity</b> Kapasiti 能力	Length: 15 - 35mm (5/8" - 1-3/8")
<b>Operating Pressure</b> Tekanan Beroperasi 使用气压	Gauge: 23Ga 0.45 - 0.69MPa (65 - 100PSI)
<b>Magazine Capacity</b> Bilangan Staples 装订个数	130
<b>Dimensions (L x W x H)</b> Dimensi 体积	208x66x191mm (8-3/16"x2-5/8"x7-1/2")
<b>Net Weight</b> Berat Bersih 净重	0.9kg (2lbs.)

Accessories (optional)			
Description	Size	Pcs/ Box	Part No.
Brad Nail 15mm (5/8")	F15	5,000	B-04307
Brad Nail 20mm (3/4")	F20	5,000	B-04313
Brad Nail 25mm (1")	F25	5,000	B-04329
Brad Nail 30mm (1-3/16")	F30	5,000	B-04335
Brad Nail 35mm (1-3/8")	F35	5,000	B-04357

## AF601

**Pneumatic Finish Nailer**  
Mesin Pemaku Pneumatik  
气钉枪



- **Lightweight for reduced operator fatigue**  
Ringan untuk mengurangi kelelahan pengguna  
轻量不易引起疲劳

Standard Equipment: Safety Goggles, Nose Adapter, Oil



<b>Capacity</b> Kapasiti 能力	Length: 25 - 64mm (1" - 2-1/2")
<b>Operating Pressure</b> Tekanan Beroperasi 使用气压	Gauge: 16Ga 0.49 - 0.83MPa (70 - 120PSI)
<b>Magazine Capacity</b> Bilangan Staples 装订个数	100
<b>Dimensions (L x W x H)</b> Dimensi 体积	304x95x297mm (12"x3-3/4"x11-3/4")
<b>Net Weight</b> Berat Bersih 净重	1.7kg (3.8lbs.)

Accessories (optional)			
Description	Size	Pcs/ Box	Part No.
Brad Nail 25mm (1")	F25	5,000	B-04329
Brad Nail 30mm (1-3/16")	F30	5,000	B-04335
Brad Nail 35mm (1-3/8")	F35	5,000	B-04357

## AF635

**Pneumatic Finish Nailer**  
Mesin Pemaku Pneumatik  
气钉枪



- **Lightweight for reduced operator fatigue**  
Ringan untuk mengurangi kelelahan pengguna  
轻量不易引起疲劳

Standard Equipment: Safety Goggles, Nose Adapter, Oil



<b>Capacity</b> Kapasiti 能力	Length: 32 - 64mm (1-1/4" - 2-1/2")
<b>Operating Pressure</b> Tekanan Beroperasi 使用气压	Gauge: 15Ga 0.49 - 0.83MPa (70 - 120PSI)
<b>Magazine Capacity</b> Bilangan Staples 装订个数	100
<b>Dimensions (L x W x H)</b> Dimensi 体积	339x100x309mm (13-3/8"x3-15/16"x12-1/8")
<b>Net Weight</b> Berat Bersih 净重	1.8kg (4lbs.)

Accessories (optional)			
Description	Size	Pcs/ Box	Part No.
Brad Nail 35mm (1-3/8")	F35	5,000	B-04357



# OTHERS

## AT638A

**Narrow Crown Stapler**  
Mesin Pemaku Pneumatik  
气钉枪



- **Lightweight for reduced operator fatigue**  
Ringan untuk mengurangkan keletihan pengguna  
轻量不易引起疲劳

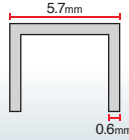

**Standard Equipment:**  
Safety Goggles, Nose Adapter, Oil



<b>Capacity</b> Kapasiti 能力	<b>Length: 13 - 38mm (1/2" - 1-1/2")</b> Gauge: 15Ga Width: 5.7mm
<b>Operating Pressure</b> Tekanan Beroperasi 使用气压	<b>0.49 - 0.83MPa (70 - 120PSI)</b>
<b>Magazine Capacity</b> Bilangan Staples 装订个数	<b>100</b>
<b>Dimensions (L x W x H)</b> Dimensi 体积	<b>230x75x251mm (9"x2-15/16"x9-7/8")</b>
<b>Net Weight</b> Berat Bersih 净重	<b>1.2kg (2.7lbs.)</b>



## Heat Gun Accessories (Optional)

Pistol Udara Panas 热风枪

Shape	Part No.
Glass protection nozzle	PR00000028
Wide-slot nozzle	PR00000029
Reflector nozzle	PR00000030
Reduction nozzle 20	PR00000031
Overlap welding nozzle	PR00000032
Solder sleeves reflector	PR00000033

Shape	Part No.
Welding nozzle	PR00000034
Pressure roller	PR00000035
Welding rods	ABS PR00000036
	HDPE PR00000037
	PP PR00000038
Speed welding nozzle	PR00000039
Scraper	PR00000040
Scraper set	PR00000041
Scraper	PR00000042

## HG6530VK

**Heat Gun**  
Pistol Udara Panas  
热风枪



- **3-speed blower settings for greater versatility**  
Kawalan kelajuan 3 tahap untuk pelbagai aplikasi  
3速度控制适合多种用途

**Standard Equipment:** Glass Protection Nozzle, Reflector Nozzle, Reduction Nozzle, Wide Slot Nozzle



<b>Air Temperature (°C)</b> Suhu Udara 气温	<b>50 - 650</b>
<b>Air Flow</b> Aliran Udara 空气流量	Stage 1: 500 L/min Stage 2: 280 L/min Stage 3: 550 L/min
<b>Dimensions (L x W x H)</b> Dimensi 体积	<b>257x85x206mm (10-1/8"x3-3/8"x8-1/8")</b>
<b>Net Weight</b> Berat Bersih 净重	<b>0.72kg (1.6lbs.)</b>
<b>Power Supply Cord</b> Kabel Wayar 电源线	<b>2.0m (6.6ft)</b>

Cordless  
Tangkas Kord 无线式

LED Flashlight  
Lampu Suluh LED  
LED手电筒

Vacuum Cleaner  
Pembersih Vakuum  
吸尘器

Drilling / Fastening  
Cairul / Pemastak  
钻孔 / 紧固

Impact Drilling / Demolition  
Cairul / Pemastak  
石工钻孔 / 拆毁动工

Cutting  
Pemotong  
切割

Grinding / Sanding  
Pengamiran / Pemoles  
研磨 / 打磨

Sawing  
Gergaji  
锯切

Planing / Routing  
Penyojukan / Tunggaman  
刨削 / 磨削

Others  
Lain-lain  
其他

Outdoor Power Equipment  
Alatan Kuasa Luar  
园林户外

Makita  
19157

# OTHERS

## HG6531CK

### Heat Gun

Pistol Udara Panas  
热风枪



- **5-speed blower settings for greater versatility**  
Kawalan kelajuan 5 tahap untuk pelbagai aplikasi  
5速度控制适合多种用途



<b>Air Temperature (°C)</b> Suhu Udara 气温	50 - 650
<b>Air Flow</b> Aliran Udara 空气流量	200 - 550 L/min
<b>Dimensions (L x W x H)</b> Dimensi 体积	257x85x206mm (10-1/8"x3-3/8"x8-1/8")
<b>Net Weight</b> Berat Bersih 淨重	0.71kg (1.6lbs.)
<b>Power Supply Cord</b> Kabel Wayar 电源线	2.0m (6.6ft)

## HG6031VK

### Heat Gun

Pistol Udara Panas  
热风枪



- **9-temperature settings (50 - 600°C) for a variety of applications**  
9 tetapan suhu (50 - 600°C) sesuai untuk pelbagai aplikasi  
9个温度设定 (50 - 600°C) 适合于各种用途

**Standard Equipment:** Glass Protection Nozzle, Reflector Nozzle, Reduction Nozzle, Wide Slot Nozzle



<b>Continuous Rating Input</b> Input Kuasa Berterusan 额定输入功率	1,800W
<b>Air Temperature (°C) / Flow (L/min)</b> Suhu Udara 气温	Switch 1: 50 - 400 / 250 Switch 2: 100 - 600 / 500
<b>Dimensions (L x W x H)</b> Dimensi 体积	257x85x206mm (10-1/8"x3-3/8"x8-1/8")
<b>Net Weight</b> Berat Bersih 淨重	0.67kg (1.5lbs)
<b>Power Supply Cord</b> Kabel Wayar 电源线	2.0m (6.6ft)

## HG5030K

### Heat Gun

Pistol Udara Panas  
热风枪



- **2 temperature settings (350 and 500°C)**  
2 tetapan suhu (350 dan 500°C)  
2个温度设定 (350和500°C)

**Standard Equipment:** Glass Protection Nozzle, Reflector Nozzle, Reduction Nozzle, Wide Slot Nozzle



<b>Continuous Rating Input</b> Input Kuasa Berterusan 额定输入功率	1,600W
<b>Air Temperature (°C) / Flow (L/min)</b> Suhu Udara 气温	Switch 1: 350 / 300 Switch 2: 500 / 500
<b>Dimensions (L x W x H)</b> Dimensi 体积	233x80x208mm (9-1/8"x3-1/8"x8-3/16")
<b>Net Weight</b> Berat Bersih 淨重	0.56kg (1.2lbs)
<b>Power Supply Cord</b> Kabel Wayar 电源线	2.0m (6.6ft)

## SK104Z

### Cross Line Laser

Laser Garis Salib  
十字线激光



- **Accuracy +/- 3mm @ 10m**  
Ketepatan +/- 3mm @ 10m  
精确度 +/- 3mm @ 10m

**Standard Equipment:** Wall Mount Bracket, Target Plate, AA Battery, Pouch with strap

<b>Measuring Range</b> Jarak Mengukur 测量范围	Up to: 15m w/ detector up to: 60m
<b>Leveling Accuracy</b> Menunjukkan Ketepatan 指示精确度	±3mm/ 10m
<b>Self-leveling Range</b> Julat Indikasi Menegak 垂直指示范围	4+-1°
<b>Laser Fan Angle</b> Sudut Peminat Laser 激光扇角	Horizontal: 180° Vertical: 180°
<b>Number of Laser</b> Bilangan Garisan Laser 激光线数量	points: 4 lines: 2
<b>Laser Type</b> Jenis Laser 激光类型	Laser class 2: 635nm
<b>Tripod Thread</b> Tripod 脚架	1/4"
<b>Protection Class</b> Tahap Perlindungan 保护等级	IP54
<b>Net Weight</b> Berat Bersih 淨重	0.53kg (1.17lbs)

## LD030P

### Laser Distance Measure

Langkah Jarak Laser  
激光测距



- **Measuring distance operating range up to 30m**  
Mengukur jarak operasi jarak sehingga 30m  
测量距离可达30米

**Standard Equipment:** AAA Alkaline Dry Battery 1.5V x2

<b>Measuring Range</b> Jarak Mengukur 测量范围	0.2-30m
<b>Typical Measuring Tolerance</b> Toleransi Mengukur Biasa 典型的测量公差	±2.0mm/ 10m
<b>Max Measuring Tolerance</b> Toleransi Mengukur Maksimum 最大测量公差	±3.0mm/ 10m
<b>Diameter of Laser Point</b> Diameter Titik Laser 激光点的直径	6mm/ 10m
<b>Laser Type</b> Jenis Laser 激光类型	Laser class 2: 635nm
<b>Dimensions (H x D x W)</b> Dimensi 体积	117x53x25mm (4.5"x2.14"x1")
<b>Net Weight</b> Berat Bersih 淨重	0.1kg (0.22lbs)

# OTHERS

## LD050P

### Laser Distance Measure

Langkah Jarak Laser  
激光测距



- **Measuring distance operating range up to 50m**  
Mengukur jarak operasi jarak sehingga 50m  
测量距离可达50米

Standard Equipment: AAA Alkaline Dry Battery 1.5V x2, Pouch

<b>Measuring Range</b> Jarak mengukur 测量范围	0.05-50m
<b>Power Supply</b> Bekalan Kuasa 电源	Cell battery : AAA 1.5V x 2pcs
<b>Net Weight</b> Berat Bersih 净重	0.1kg (0.22lbs)

## LD080P / PI

### Laser Distance Measure

Langkah Jarak Laser  
激光测距



- **Measuring distance operating range up to 80m**  
Mengukur jarak operasi jarak sehingga 80m  
测量距离可达80米

Standard Equipment: AAA Alkaline Dry Battery 1.5V x2,  
Carrying Strap, Pouch

<b>Measuring Range</b> Jarak mengukur 测量范围	0.05-80m
<b>Power Supply</b> Bekalan Kuasa 电源	Cell battery : AAA 1.5V x 2pcs
<b>Net Weight</b> Berat Bersih 净重	0.14kg (0.31lbs)

## UB1103

### Blower

Mesin Blower  
吹风机



- **Two tools in one; quickly converts to a vacuum for added versatility**  
Alat 2 dalam 1, vakum dan blower untuk fleksibiliti tambahan  
一机2用, 集尘与吹风

Standard Equipment: Nozzle, Dust Bag



<b>Continuous Rating Input</b> Input Kuasa Berterusan 额定输入功率	600W
<b>Max Air Volume</b> Isipadu Angin Maksimum 最大风量	0 - 4.1m <sup>3</sup> /min
<b>Max Air Velocity</b> Velositi Angin Maksimum 最大风速	0 - 91m/s
<b>Air Pressure</b> Tekanan Udara 气压	0 - 5.7kPa
<b>No Load Speed (RPM)</b> Kelajuan Tanpa Beban 回转数	0 - 16,000
<b>Dimensions (L x W x H)</b> Dimensi 体积	479x185x178mm (18-7/8"x7-1/4"x7")
<b>Net Weight</b> Berat Bersih 净重	1.9 - 2.2kg (4.3 - 4.8lbs)
<b>Power Supply Cord</b> Kabel Wayar 电源线	2.5m (8.2ft.)

## HS100

### Hammer Tacker

Alat Manual Memaku Mesin  
手动工具敲钉机



<b>Capacity</b> Kapasiti 能力	Width: 12mm Length: 6 - 10mm
<b>Magazine Capacity</b> Bilangan Staples 装订个数	144
<b>Dimensions (L x W x H)</b> Dimensi 体积	281mm
<b>Net Weight</b> Berat Bersih 净重	0.5kg



Cordless  
Tanpa Kabel 无线式

LED Flashlight  
Lampu Suluh LED  
LED照明灯

Vacuum Cleaner  
Pembersih Vakuum  
吸尘器

Drilling / Fastening  
Cairul / Pengikat  
钻孔 / 紧固

Impact Drilling / Demolition  
Cairul / Pemusnah  
石工钻孔 / 摧毁动工

Cutting  
Pemotong  
切割机

Grinding / Sanding  
Pengkil / Pemois  
研磨 / 砂磨

Sawing  
Gergaji  
锯切

Planing / Routing  
Penyoakan / Tonggaman  
刨削 / 雕刻

Others  
Lain-lain  
其他

Outdoor Power Equipment  
Alatan Kuasa Luar  
园林户外

Makita  
1915

Cordless  
Tali Kosong 无线式

LED Flashlight  
Lampu Suhu LED  
LED 照明灯

Vacuum Cleaner  
Pembersih Vakuum  
吸尘器

Drilling / Fastening  
Dropl / Pengikat  
钻孔 / 紧固

Impact Drilling / Demolition  
Dropl / Penceroboh  
冲击钻孔 / 拆除加工

Cutting  
Pemotongan  
切割

Grinding / Sanding  
Pengkilan / Pasir  
打磨 / 磨光

Sawing  
Gergaji  
锯切

Planing / Routing  
Pencalam / Tumpang  
刨削 / 雕刻

Others  
Lain-lain  
其他

Outdoor Power Equipment  
Alat Kuasa Luar  
户外动力工具

Makita  
Makita

# OUTDOOR POWER EQUIPMENT

Alat Berkebun 园艺工具



## EBH340U 33.5mL 4-stroke

### Petrol Brushcutter

Pemotong Rumput Petrol  
汽油割草机



- Meets all environmental standards  
Memenuhi standard mesra alam  
符合所有环保标准

Standard Equipment: Star Blade, Protector, Hex Wrench, Socket Wrench, Oil (195501-2), Accessory Bag



<b>Displacement</b> Sesaran 排量	33.5mL
<b>Engine Power</b> Kuasa Enjin 发动机功率	1.07kW/ 1.5PS
<b>Fuel Tank Capacity</b> Tangki Minyak 油箱容量	0.65L
<b>Spindle Size</b> Saiz Spindel 主轴尺寸	M10 x 1.25LH
<b>Dimensions (L x W x H)</b> Dimensi 体积	1,900x645x510mm (74-3/4"x25-3/8"x20")
<b>Net Weight</b> Berat Bersih 净重	7.5kg (16.5lbs)

## EM2654LH 25.4mL 4-stroke

### Petrol Brushcutter

Pemotong Rumput Petrol  
汽油割草机

- No oil mixing needed. Lower emissions  
Tanpa pencampuran petrol, perlepasan asap lebih rendah  
无需汽油混合，降低排气

Standard Equipment: Shoulder Harness, Metal Blade / Nylon Cutting Head (country-specific), Blade cover (for the product with metal blade), Box Driver, Hex Wrench, Accessory Bag



<b>Displacement</b> Sesaran 排量	25.4mL
<b>Max Output</b> Keluaran Maksima 最大输出	0.77kW (1.1HP) @ 7,000RPM
<b>Fuel Tank Capacity</b> Tangki Minyak 油箱容量	0.6L (20.3 oz.)
<b>Oil Tank Capacity</b> Kapasiti Tangki Minyak 润滑油箱	0.08L (2.7 oz.)
<b>Cutting Width</b> Lebar Keratan 切割宽度	Metal Blade: 230mm (9-1/16") Nylon Cutting Head: 420mm (16-1/2")
<b>Spindle Size</b> Saiz Spindel 主轴尺寸	M10 x 1.25LH
<b>Dimensions (L x W x H)</b> Dimensi 体积	1,765x368x293mm (69-1/2"x14-1/2"x11-1/2")
<b>Net Weight</b> Berat Bersih 净重	5.2kg (11.5lbs)

## RBC411U 40.2mL

### Petrol Brushcutter

Pemotong Rumput Petrol  
汽油割草机



- Powerful and reliable 40.2mL engine  
Enjin 40.2mL yang kuat dan boleh dipercayai  
强力可靠的40.2mL引擎

Standard Equipment: Metal Blade, Protector, Shoulder Belt, Tool Set, Accessory Bag



<b>Displacement</b> Sesaran 排量	40.2mL
<b>Engine Power</b> Kuasa Enjin 发动机功率	1.40kW/ 2.0PS
<b>Fuel Tank Capacity</b> Tangki Minyak 油箱容量	1.1L
<b>Spindle Size</b> Saiz Spindel 主轴尺寸	M10 x 1.25LH
<b>Dimensions (L x W x H)</b> Dimensi 体积	1,710x670x430mm (67-1/2"x26-3/8"x17")
<b>Net Weight</b> Berat Bersih 净重	7.3kg (16.1lbs)

## EM3400U 34.0mL

### Petrol Brushcutter

Pemotong Rumput Petrol  
汽油割草机



- Waist cushion for added comfort in long continuous operation  
Kusyen pinggang untuk keselesaan tambahan dalam operasi berterusan yang panjang  
腰部靠垫在长时间连续操作中增加了舒适度

Standard Equipment: Metal Blade, Protector, Blade Cover, Accessory Bag, Shoulder harness with double shoulder strap, Socket Wrench, Hex Wrench



<b>Displacement</b> Sesaran 排量	34.0mL
<b>Engine Power</b> Kuasa Enjin 发动机功率	1.15kW/ 1.6PS
<b>Fuel Tank Capacity</b> Tangki Minyak 油箱容量	0.75L
<b>Spindle Size</b> Saiz Spindel 主轴尺寸	M10 x 1.25LH
<b>Dimensions (L x W x H)</b> Dimensi 体积	1,815x650x435mm (71-1/2"x25-1/2"x17-1/8")
<b>Net Weight</b> Berat Bersih 净重	6.4kg (14.1lbs)

# OUTDOOR POWER EQUIPMENT

## EM3400L 34.0mL

### Petrol Brushcutter

Pemotong Rumput Petrol  
汽油割草机



- **Lightweight for reduced operator fatigue**  
Ringan untuk mengurangkan keletihan pengguna  
轻量, 减少使用者的疲劳

**Standard Equipment:** Cutter Blade (196895-8), Protector, Band Assembly, Socket Wrench, Hex Wrench, Screwdriver, Accessory Bag



<b>Displacement</b> Sesaran 排量	34.0mL
<b>Engine Power</b> Kuasa Enjin 发动机功率	1.15kW/ 1.6PS
<b>Fuel Tank Capacity</b> Tangki Minyak 油箱容量	0.75L
<b>Spindle Size</b> Saiz Spindel 主轴尺寸	M10 x 1.25LH
<b>Dimensions (L x W x H)</b> Dimensi 体积	1,815x330x270mm (71-1/2"x13"x10-5/8")
<b>Net Weight</b> Berat Bersih 净重	6.2kg (13.7lbs)

## EM2600U 25.7mL 2-stroke

### Petrol Brushcutter

Pemotong Rumput Petrol  
汽油割草机



- **Primer bulb and choke for easy starting**  
Mudah dihidupkan  
易于启动

**Standard Equipment:** Star Blade, Nylon Cutting Head, Socket Wrench, Hex Wrench, Shoulder Belt



<b>Displacement</b> Sesaran 排量	25.7mL
<b>Engine Power</b> Kuasa Enjin 发动机功率	0.83kW/ 1.2PS
<b>Fuel Tank Capacity</b> Tangki Minyak 油箱容量	0.6L
<b>Spindle Size</b> Saiz Spindel 主轴尺寸	M8 x 1.25LH
<b>Dimensions (L x W x H)</b> Dimensi 体积	1,770x610x410mm (69-3/4"x24"x16-1/8")
<b>Net Weight</b> Berat Bersih 净重	5kg (11lbs)

## EM4350RH 43.0mL 4-stroke

### Backpack Petrol Brushcutter

Pemotong Rumput Beg Galas  
Petrol  
背负式汽油割草机



- **4-stroke engine requires no fuel mix**  
Enjin 4-strok tidak memerlukan campuran minyak  
四冲程发动机不需要混合燃料

**Standard Equipment:** Metal Blade, Protector, Blade cover, Accessory Bag, Oil, Box Wrench



<b>Displacement</b> Sesaran 排量	43.0mL
<b>Engine Power</b> Kuasa Enjin 发动机功率	1.5kW/ 2.1PS
<b>Fuel Tank Capacity</b> Tangki Minyak 油箱容量	0.8L
<b>Spindle Size</b> Saiz Spindel 主轴尺寸	M10 x 1.25LH
<b>Dimensions (L x W x H)</b> Dimensi 体积	358x280x587mm (14-1/8"x11"x23-1/8")
<b>Net Weight</b> Berat Bersih 净重	12.1kg (26.7lbs)

## EBH340R 33.5mL 4-stroke

### Backpack Petrol Brushcutter

Pemotong Rumput Beg Galas  
Petrol  
背负式汽油割草机



- **Powerful fuel efficient 33.5cc MM4 commercial duty engine**  
Enjin berat komersial MM4 33.5cc  
强力的33.5cc MM4商用引擎

**Standard Equipment:** Blade, Tool set



<b>Displacement</b> Sesaran 排量	33.5mL
<b>Engine Power</b> Kuasa Enjin 发动机功率	1.07kW/ 1.45PS
<b>Fuel Tank Capacity</b> Tangki Minyak 油箱容量	0.65L
<b>Spindle Size</b> Saiz Spindel 主轴尺寸	M10 x 1.25LH
<b>Dimensions (L x W x H)</b> Dimensi 体积	400x325x395mm (15-3/4"x12-3/4"x15-1/2")
<b>Net Weight</b> Berat Bersih 净重	9.8kg (21.6lbs)

## EE2650H 25.4mL 4-stroke

### Petrol Edger

Pemotong Rumput Petrol  
汽油草坪修边机



- **Plate on gear housing for protection against contact to concrete**  
Plat pada gear untuk perlindungan daripada tersentuh konkrit  
防止与混凝土接触的齿轮箱

**Standard Equipment:** Blade, Socket Wrench, Hex Wrench, Accessory Bag



<b>Displacement</b> Sesaran 排量	25.4mL
<b>Engine Power</b> Kuasa Enjin 发动机功率	0.77kW/ 1.1PS
<b>Fuel Tank Capacity</b> Tangki Minyak 油箱容量	0.6L
<b>Dimensions (L x W x H)</b> Dimensi 体积	1,773x242x315mm (69-3/4"x9-1/2"x12-3/8")
<b>Net Weight</b> Berat Bersih 净重	6.6kg (14.6lbs)

Cordless  
Tenggakord 30.6L

LED Flashlight  
Lampu Suluh LED  
LED 闪光灯

Vacuum Cleaner  
Pembersih Vakuam  
吸尘器

Drilling / Fastening  
Cairul / Pengikat  
钻孔 / 紧固

Impact Drilling / Demolition  
Cairul / Persekit  
石工钻孔 / 拆毁施工

Cutting  
Pemotong  
切割

Grinding / Sanding  
Pengkilan / Pasukan  
打磨 / 砂磨

Sawing  
Cairul  
锯切

Planing / Routing  
Pecutan / Tanggapan  
刨削 / 雕刻

Others  
Lain-lain  
其他

Outdoor Power Equipment  
Alatan Kerpah Luar  
园林户外

Makita  
MAKITA

# OUTDOOR POWER EQUIPMENT

## ETR2500 24.5mL

**Petrol Edging Trimmer**  
Pemotong Rumput Petrol  
汽油草坪修边机



- **Very powerful 2-stroke engine**  
Enjin 2-strok yang berkuasa  
强大的二冲程引擎

Standard Equipment: Single harness, Tool set



<b>Displacement</b> Sesaran 排量	24.5mL
<b>Engine Power</b> Kuasa Enjin 发动机功率	0.73kW/ 0.99PS
<b>Fuel Tank Capacity</b> Tangki Minyak 油箱容量	0.5L
<b>Dimensions (L x W x H)</b> Dimensi 体积	1,760x395x220mm (69-1/4"x15-1/2"x8-5/8")
<b>Net Weight</b> Berat Bersih 净重	5.1kg (12.1lbs)

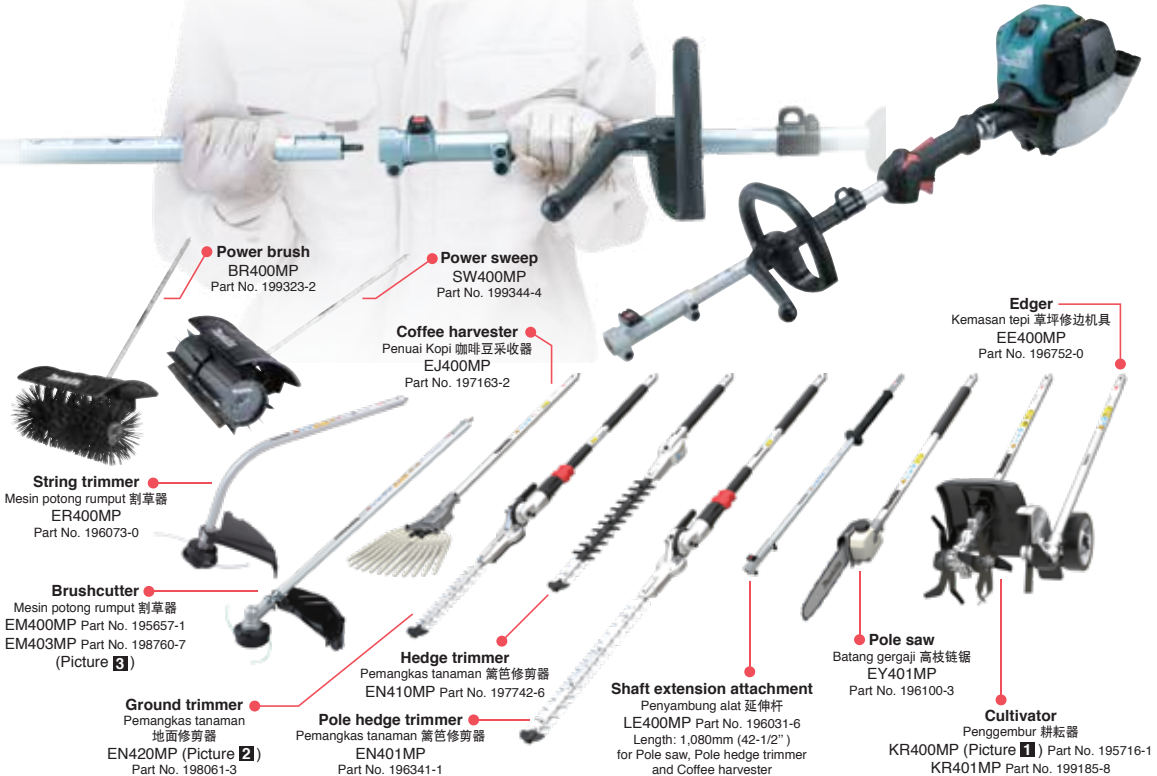

**Power brush**  
BR400MP  
Part No. 199323-2

**Power sweep**  
SW400MP  
Part No. 199344-4

**Coffee harvester**  
Penuai Kopi 咖啡豆采收器  
EJ400MP  
Part No. 197163-2

**String trimmer**  
Mesin potong rumput 割草器  
ER400MP  
Part No. 196073-0

**Brushcutter**  
Mesin potong rumput 割草器  
EM400MP Part No. 195657-1  
EM403MP Part No. 198760-7  
(Picture 3)

**Ground trimmer**  
Pemangkas tanaman  
地面修剪器  
EN420MP (Picture 2)  
Part No. 198061-3

**Hedge trimmer**  
Pemangkas tanaman 篱笆修剪器  
EN410MP Part No. 197742-6

**Pole hedge trimmer**  
Pemangkas tanaman 篱笆修剪器  
EN401MP  
Part No. 196341-1

**Shaft extension attachment**  
Penyambung alat 延伸杆  
LE400MP Part No. 196031-6  
Length: 1,080mm (42-1/2")  
for Pole saw, Pole hedge trimmer  
and Coffee harvester

**Pole saw**  
Batang gergaji 高枝链锯  
EY401MP  
Part No. 196100-3

**Edger**  
Kemasan tepi 草坪修边机具  
EE400MP  
Part No. 196752-0

**Cultivator**  
Penggembur 耕耘器  
KR400MP (Picture 1) Part No. 195716-1  
KR401MP Part No. 199185-8

## EX2650LHM 25.4mL 4-stroke

**Multi Function Power Head**  
Powerhead Pelbagai Fungsi  
多功能动力头



- **Makita Mini 4-Stroke motors offer cleaner exhaust emissions and reduced fuel consumption**  
Motor Mini 4-Stroke Makita mengurangkan pelepasan asap dan penggunaan bahan api  
Makita迷你四冲程马达降低废气排放和减少燃料消耗

Standard Equipment: Band Assembly, Socket Wrench, Hex Wrench, Oil (195500-4), Accessory Bag



<b>Displacement</b> Sesaran 排量	25.4mL
<b>Engine Power</b> Kuasa Enjin 发动机功率	0.77kW/ 1.1PS
<b>Fuel Tank Capacity</b> Tangki Minyak 油箱容量	0.6L
<b>Dimensions (L x W x H)</b> Dimensi 体积	975x323x241mm (38-3/8"x12-3/4"x9-1/2")
<b>Net Weight</b> Berat Bersih 净重	4.6kg (10lbs)

## UC3551A 350mm (14") | UC4051A 400mm (16") 153

**Electric Chain Saw**  
Gergaji Rantai  
电链锯



- **Fast and efficient cutting**  
Pemotongan cepat dan cekap  
快速高效的切割

Standard Equipment: Saw Chain, Guide Bar, Guide Bar Cover, Hook Complete



<b>Continuous Rating Input</b> Input Kuasa Berterusan 额定输入功率	1,800W
<b>Chain Speed per Minute</b> Kelajuan Rantai 链条速度	870m (2,900ft)
<b>Guide Bar Length</b> Panjang Batang Gergaji 切割长度	350mm (14") UC3551A 400mm (16") UC4051A
<b>Saw Chain</b> Rantai 链条	Pitch : 3/8" Gauge : 1.3mm (0.050")
<b>Dimensions (L x W x H)</b> Dimensi 体积	505x200x220mm (19-7/8"x7-7/8"x8-5/8")
<b>Net Weight</b> Berat Bersih 净重	5.5kg (12.1lbs) UC3551A 5.6kg (12.3lbs) UC4051A
<b>Power Supply Cord</b> Kabel Wayar 电源线	0.3m (0.98ft)

Cordless  
Terdapat Model Tanpa Kabel

LED Flashlight  
Lampu Boleh LED  
LED 照明灯

Vacuum Cleaner  
Pembersih Vakuum  
吸尘器

Drilling / Fastening  
Operasi / Pengetat  
钻孔 / 紧固

Impact Drilling / Demolition  
Detah / Pevencat  
冲击钻孔 / 拆除加工

Cutting  
Pemotongan  
切割

Grinding / Sanding  
Pengisar / Pasir  
打磨 / 磨光

Sawing  
Gergaji  
锯切

Planing / Routing  
Pegyalan / Tunggaman  
刨削 / 雕刻

Others  
Lain-lain  
其他

Outdoor Power Equipment  
Alatan Kuasa Luar  
户外动力设备

Makita  
Makita

# OUTDOOR POWER EQUIPMENT

## UC3541A 350mm (14") | UC4041A 400mm (16") 132

### Electric Chain Saw

Gergaji Rantai  
电链锯



- **Zero emissions and reduced maintenance**  
Tanpa perlepasan asap & penyelenggaraan rendah  
无排气及降低保养维护



**Standard Equipment:** Saw Chain, Guide Bar, Guide Bar Cover, Hook Complete



<b>Continuous Rating Input</b> Input Kuasa Berterusan 额定输入功率	1,800W
<b>Chain Speed per Minute</b> Kelajuan Rantai 链条速度	870m (2,900ft)
<b>Guide Bar Length</b> Panjang Batang Gergaji 切割长度	350mm (14") UC3541A 400mm (16") UC4041A
<b>Saw Chain</b> Rantai 链条	Pitch : 3/8" Gauge: 1.1mm (0.043")/ 1.3mm (0.050")
<b>Dimensions (L x W x H)</b> Dimensi 体积	455x245x200mm (17-7/8"x9-5/8"x7-7/8")
<b>Net Weight</b> Berat Bersih 净重	4.7 - 4.9kg (10.4 - 10.6lbs)
<b>Power Supply Cord</b> Kabel Wayar 电源线	0.3m (0.98ft)

## 5016B 405mm (16") 153

### Electric Chain Saw

Gergaji Rantai  
电链锯



- **Compact and lightweight design**  
Reka bentuk padat dan ringan  
小巧轻便的设计



**Standard Equipment:** Saw Chain, Oil supply 100ml, Socket Wrench, File, Screwdriver



<b>Continuous Rating Input</b> Input Kuasa Berterusan 额定输入功率	1,300W
<b>Chain Speed per Minute</b> Kelajuan Rantai 链条速度	400m (1,310ft)
<b>Guide Bar Length</b> Panjang Batang Gergaji 切割长度	405mm (16")
<b>Saw Chain</b> Rantai 链条	Pitch : 3/8" Gauge: 1.3" or 0.050"
<b>Overall Length</b> Panjang Keseluruhan 总长度	750mm (29-1/2")
<b>Net Weight</b> Berat Bersih 净重	5.8kg (12.7lbs)
<b>Power Supply Cord</b> Kabel Wayar 电源线	5.0m (16.4ft)

## EA3201S40B 400mm (16")

### Petrol Chain Saw

Gergaji Rantai Petrol  
汽油链锯



- **Touch & stop switch system keeps spark plug from getting wet**  
Sistem suis mengelakkan palam cucuh daripada menjadi basah  
可防止火花塞受潮的开关系统



**Standard Equipment:** Guide Bar, Saw Chain, Guide Bar Cover, Steel spike bumper, Socket Wrench, Screwdriver



<b>Saw Chain</b> Rantai 链条	Pitch : 3/8" Gauge: 1.1mm (0.043")/ 1.3mm (0.050")
<b>Displacement</b> Sesaran 排量	32mL
<b>Engine Power</b> Kuasa Enjin 发动机功率	1.35kW/ 1.9PS
<b>Fuel Tank Capacity</b> Tangki Minyak 油箱容量	0.4L
<b>Chain Oil Tank Volume</b> Tangki Minyak Pelincir 链油箱	0.28L
<b>Dimensions (L x W x H)</b> Dimensi 体积	405x269x273mm (16"x10-5/8"x10-3/4")
<b>Power Head Weight</b> Berat Kepala Kuasa 动力头重量	4.2kg (9.3lbs.)

## EA3502S40B 400mm (16")

### Petrol Chain Saw

Gergaji Rantai Petrol  
汽油链锯

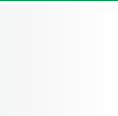

- **External access holes allow easy carburetor adjustment**  
Lubang akses luar membolehkan pelarasan karburetor mudah  
外部进入孔允许简单的化油器调整



**Standard Equipment:** Saw Chain, Guide bar, Guide Bar Cover, Socket Wrench, (+) Screwdriver



<b>Saw Chain</b> Rantai 链条	Pitch : 3/8" Gauge: 1.1mm (0.043")/ 1.3mm (0.050")
<b>Displacement</b> Sesaran 排量	35.0mL
<b>Engine Power</b> Kuasa Enjin 发动机功率	1.7kW/ 2.4PS
<b>Fuel Tank Capacity</b> Tangki Minyak 油箱容量	0.4L
<b>Chain Oil Tank Volume</b> Tangki Minyak Pelincir 链油箱	0.29L
<b>Dimensions (L x W x H)</b> Dimensi 体积	415x247x273mm (16-3/8"x9-3/4"x10-3/4")
<b>Net Weight</b> Berat Kepala Kuasa 动力头重量	4.4kg (9.7lbs)

## EA4301F45B 450mm (18")

### Petrol Chain Saw

Gergaji Rantai Petrol  
汽油链锯



- **Increased output power**  
Peningkatan kuasa output  
增加输出功率



**Standard Equipment:** Saw Chain, Guide Bar, Guide Bar Cover, Socket Wrench, Hex Wrench, Screwdriver



<b>Saw Chain</b> Rantai 链条	Pitch : 0.325" or 3/8" Gauge: 1.3mm (0.050")
<b>Displacement</b> Sesaran 排量	42.4mL
<b>Engine Power</b> Kuasa Enjin 发动机功率	2.2kW/ 3.0PS
<b>Fuel Tank Capacity</b> Tangki Minyak 油箱容量	0.48L
<b>Chain Oil Tank Volume</b> Tangki Minyak Pelincir 链油箱	0.28L
<b>Dimensions (L x W x H)</b> Dimensi 体积	416x248x279mm (16-3/8"x9-3/4"x11")
<b>Power Head Weight</b> Berat Kepala Kuasa 动力头重量	4.8kg (10.5lbs.)

Cordless  
Tenggakord 0.6米

LED Flashlight  
Lampu Suluh LED  
LED 0.8米

Vacuum Cleaner  
Pembersih Vakuam  
0.3米

Drilling | Fastening  
Cawan | Pengikat  
钻头 | 螺絲

Impact Drilling | Demolition  
Cawan | Pemecah  
打土钻头 | 敲擊工具

Cutting  
Pemotong  
切割

Grinding | Sanding  
Pengkilan | Polesan  
砂磨 | 打磨

Sawing  
Cergasi  
锯切

Planing | Routing  
Pegyalan | Tanggapan  
刨削 | 鑿削

Others  
Lain-lain  
其他

Outdoor Power Equipment  
Alatan Kuasa Luar  
園林工具



# OUTDOOR POWER EQUIPMENT

Cordless  
Tangan Keras 无绳式

LED Flashlight  
Lampu Suhu LED  
LED 照明灯

Vacuum Cleaner  
Pembersih Vakuum  
吸尘器

Drilling / Fastening  
Dapat / Pengikat  
钻孔 / 紧固

Impact Drilling / Demolition  
Dobrak / Penusuk  
冲击钻孔 / 拆除加工

Cutting  
Pemotong  
切割

Grinding / Sanding  
Pengamiran / Habis  
打磨 / 磨光

Sawing  
Dagang  
锯切

Planing / Routing  
Pencyngam / Tumpang  
刨削 / 雕刻

Others  
Lain-lain  
其他

Outdoor Power Equipment  
Alat-alat Tenaga Luar  
户外动力设备

Makita  
1915

## EA6100P 600mm (24")

**Petrol Chain Saw**  
Gergaji Rantai Petrol  
汽油链锯



- Up to 20% less fuel consumption and lower emissions  
Kurang penggunaan bahan api sehingga 20% dan pelepasan asap yang lebih rendah  
燃料消耗降低20%，排放气降低



Standard Equipment: Saw Chain, Guide Bar Cover, Wrenches



<b>Saw Chain</b> Rantai 链条	Pitch : 0.325 or 3/8"
<b>Displacement</b> Sesaran 排量	60.7mL
<b>Engine Power</b> Kuasa Enjin 发动机功率	3.4kW/ 4.6PS
<b>Fuel Tank Capacity</b> Tangki Minyak 油箱容量	0.8L
<b>Chain Oil Tank Volume</b> Tangki Minyak Pelincir 链油箱	0.48L
<b>Dimensions (L x W x H)</b> Dimensi 体积	435x243x312mm (17-1/8"x9-9/16"x12-1/4")
<b>Power Head Weight</b> Berat Kepala Kuasa 动力头重量	6.0kg (13.2lbs.)

## EA7900P70E 600mm (24")

**Petrol Chain Saw**  
Gergaji Rantai Petrol  
汽油链锯



- Adjustable automatic chain lubrication with large oil reservoir  
Pelarasan pelinciran rantai automatik dengan takungan minyak yang besar  
可调自动链条润滑



Standard Equipment: Saw Chain, Guide Bar, Guide Bar Cover, Socket Wrench



<b>Saw Chain</b> Rantai 链条	Pitch : 3/8"
<b>Displacement</b> Sesaran 排量	Gauge: 1.5mm (0.058") 79mL
<b>Engine Power</b> Kuasa Enjin 发动机功率	4.3kW/ 5.8PS
<b>Fuel Tank Capacity</b> Tangki Minyak 油箱容量	0.75L
<b>Chain Oil Tank Volume</b> Tangki Minyak Pelincir 链油箱	0.42L
<b>Power Head Weight</b> Berat Kepala Kuasa 动力头重量	6.3kg (13.8lbs.)

## DCS520-53 530mm (21")

**Petrol Chain Saw**  
Gergaji Rantai Petrol  
汽油链锯



- Automatic adjustable chain oiler  
Pelarasan minyak rantai automatik  
自动调节链条油



Standard Equipment: Saw Chain, Guide Bar Cover, Wrenches



<b>Saw Chain</b> Rantai 链条	Pitch : 3/8"
<b>Displacement</b> Sesaran 排量	Gauge: 1.5mm (0.058") 52mL
<b>Power Rating</b> Kuasa Enjin 发动机功率	2.4kW
<b>Fuel Tank Capacity</b> Tangki Minyak 油箱容量	0.56L
<b>Chain Oil Tank Volume</b> Tangki Minyak Pelincir 链油箱	0.28L
<b>Power Head Weight</b> Berat Kepala Kuasa 动力头重量	4.5kg (9.9lbs.)

## DCS6401-50 500mm (20")

**Petrol Chain Saw**  
Gergaji Rantai Petrol  
汽油链锯



- Vibration damping with tough, long-life steel springs  
Getaran redaman dengan pegas keluli yang tahan lama  
减震，坚韧，而持久的钢弹簧



Standard Equipment: Saw Chain, Guide Bar Cover, Wrenches



<b>Saw Chain</b> Rantai 链条	Pitch : 3/8"
<b>Displacement</b> Sesaran 排量	Gauge: 1.5mm (0.058") 64mL
<b>Engine Power</b> Kuasa Enjin 发动机功率	3.5kW/ 4.8PS
<b>Fuel Tank Capacity</b> Tangki Minyak 油箱容量	0.75L
<b>Chain Oil Tank Volume</b> Tangki Minyak Pelincir 链油箱	0.42L
<b>Power Head Weight</b> Berat Kepala Kuasa 动力头重量	6.3kg (13.89lbs.)

## DCS7301-60 600mm (24")

**Petrol Chain Saw**  
Gergaji Rantai Petrol  
汽油链锯



- Improved air filtration through the Air master air filter system  
Penapis udara yang lebih baik  
改进的空气过滤系统改善空气过滤



Standard Equipment: Saw Chain, Guide Bar Cover, Wrenches



<b>Saw Chain</b> Rantai 链条	Pitch : 3/8"
<b>Displacement</b> Sesaran 排量	Gauge: 1.5mm (0.058") 72.6mL
<b>Engine Power</b> Kuasa Enjin 发动机功率	4.2kW/ 5.7PS
<b>Fuel Tank Capacity</b> Tangki Minyak 油箱容量	0.75L
<b>Chain Oil Tank Volume</b> Tangki Minyak Pelincir 链油箱	0.42L
<b>Power Head Weight</b> Berat Kepala Kuasa 动力头重量	6.3kg (13.89lbs.)



# OUTDOOR POWER EQUIPMENT

## DCS7901-70 700mm (28")

### Petrol Chain Saw

Gergaji Rantai Petrol  
汽油链锯



- Improved air filtration through the Air master air filter system  
Penapis udara yang lebih baik  
改进的空气过滤系统改善空气过滤

Standard Equipment: Saw Chain, Guide Bar Cover, Wrenches



Saw Chain Rantai 链条	Pitch : 3/8" Gauge: 1.5mm (0.058")
Displacement Sesaran 排量	78.5mL
Engine Power Kuasa Enjin 发动机功率	4.6kW/ 6.3PS
Fuel Tank Capacity Tangki Minyak 油箱容量	0.75L
Chain Oil Tank Volume Tangki Minyak Pelincir 链油箱	0.42L
Power Head Weight Berat Kepala Kuasa 动力头重量	6.3kg (13.89lbs.)

## DCS9010-76 740mm (29")

### Petrol Chain Saw

Gergaji Rantai Petrol  
汽油链锯



- Heavy timber saw for the hardest working for professionals  
Gergaji kayu berat untuk profesional  
适合专业人员的重型木锯

Standard Equipment: Saw Chain, Guide Bar Cover, Wrench, Screwdriver



Saw Chain Rantai 链条	Pitch : 3/8" Gauge: 1.5mm (0.058")
Displacement Sesaran 排量	90mL
Engine Power Kuasa Enjin 发动机功率	4.9kW/ 6.7PS
Fuel Tank Capacity Tangki Minyak 油箱容量	1L
Chain Oil Tank Volume Tangki Minyak Pelincir 链油箱	0.4L
Power Head Weight Berat Kepala Kuasa 动力头重量	8.2kg (18.1lbs.)

## EA3110T30B 300mm (12")

### Petrol Chain Saw

Gergaji Rantai Petrol  
汽油链锯



- Compact and lightweight body for better handling  
Padat dan ringan  
小巧轻便的机身易于操纵

Standard Equipment: Guide Bar, Saw Chain, Guide Bar Cover, Socket Wrench, Screwdriver



WHILE STOCK LAST  
Sementara stok masih ada  
有限库存

Saw Chain Rantai 链条	Pitch : 3/8" Gauge: 1.3mm (0.050")
Displacement Sesaran 排量	30.1mL
Engine Power Kuasa Enjin 发动机功率	1.0kW/ 1.4PS
Fuel Tank Capacity Tangki Minyak 油箱容量	0.24L
Chain Oil Tank Volume Tangki Minyak Pelincir 链油箱	0.18L
Dimensions (L x W x H) Dimensi 体积	259x236x217mm (10-1/4"x9-1/4"x8-1/2")
Power Head Weight Berat Kepala Kuasa 动力头重量	3.2kg (7.0lbs.)

## DCS231T 250mm (10")

### Petrol Chain Saw

Gergaji Rantai Petrol  
汽油链锯

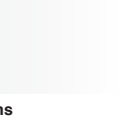

- Fast acceleration and low emissions  
Pelepasan asap yang rendah  
低排气

Standard Equipment: Saw Chain, Guide Bar, Guide Bar Cover, Wrench 13-16



Bar Length Panjang Batang Gergaji 切割长度	25cm
Displacement Sesaran 排量	22.2mL
Engine Power Kuasa Enjin 发动机功率	0.74kW
Fuel Tank Capacity Tangki Minyak 油箱容量	0.2L
Chain Oil Tank Volume Tangki Minyak Pelincir 链油箱	0.19L
Power Head Weight Berat Kepala Kuasa 动力头重量	2.5kg

## EA5600F53G 530mm (21")

### Petrol Chain Saw

Gergaji Rantai Petrol  
汽油链锯



- Excellent air filter system for reduced maintenance  
Sistem penapis udara yang sangat baik untuk mengurangkan penyelenggaraan  
卓越的空气过滤系统，减少维修

Standard Equipment: Saw Chain, Guide Bar, Guide Bar Cover, Socket Wrench



Saw Chain Rantai 链条	Pitch : 3/8" or 0.325" Gauge: 1.3mm (0.050")/ 1.5mm (0.058")
Displacement Sesaran 排量	55.7mL
Engine Power Kuasa Enjin 发动机功率	3.0kW/ 4.1PS
Fuel Tank Capacity Tangki Minyak 油箱容量	0.6L
Chain Oil Tank Volume Tangki Minyak Pelincir 链油箱	0.3L
Dimensions (L x W x H) Dimensi 体积	430x237x297mm (17"x9-3/8"x11-5/8")
Power Head Weight Berat Kepala Kuasa 动力头重量	5.8kg (12.8lbs.)

Cordless  
Tenggali Kord 无绳式

LED Flashlight  
Lampu Suluh LED  
LED照明灯

Vacuum Cleaner  
Pembersih Vakuum  
吸尘器

Drilling / Fastening  
Cairas / Pengikat  
钻孔 / 紧固

Impact Drilling / Demolition  
Cairas / Penanggal  
冲击钻孔 / 拆除施工

Cutting  
Pemotong  
切割

Grinding / Sanding  
Pengisar / Pasir  
研磨 / 打磨

Sawing  
Cergaji  
锯切

Planing / Routing  
Pecutan / Tanggung  
刨削 / 雕刻

Others  
Lain-lain  
其他

Outdoor Power Equipment  
Alatan Kaji Liat  
园林工具

Makita  
MAKITA

# OUTDOOR POWER EQUIPMENT

## EY2650H25H 25.4mL 4-stroke

### Telescopic Petrol Pole Saw

Rantai Cawangan Teleskopik Tinggi  
伸缩式高枝链锯



- Ideal for pruning and limbing in tall trees or hard to reach areas  
Sesuai untuk pemangkasan pokok-pokok yang tinggi  
适合修剪和砍伐高大树木

Standard Equipment: Blade Cover, Tool set, Oil set



<b>Displacement</b> Sesaran 排量	25.4mL
<b>Engine Power</b> Kuasa Enjin 发动机功率	0.77kW/ 1.1PS
<b>Fuel Tank Capacity</b> Tangki Minyak 油箱容量	0.6L
<b>Guide Bar Length</b> Panjang Batang Gergaji 切割长度	255mm (10")
<b>Saw Chain</b> Rantai 链条	Gauge: 1.3mm (0.050") Pitch: 3/8"
<b>Dimensions (L x W x H)</b> Dimensi 体积	2,720x223x240mm (107"x8-3/4"x9-1/2")
<b>Net Weight</b> Berat Bersih 净重	7.2kg (16.0lbs)

## UH7580X 750mm (29-1/2")

419

### Electric Hedge Trimmer

Pemangkas Tanaman Pagar  
电篱笆修剪机



- Powerful 670W motor  
Motor berkuasa 670W  
强劲的670W电机

Standard Equipment: Blade Cover, Hook complete, Belt Hook



<b>Continuous Rating Input</b> Input Kuasa Berterusan 额定输入功率	670W
<b>Blade Length</b> Panjang Bilah 锯片长度	750mm (29-1/2")
<b>Strokes Per Minute (SPM)</b> Kelajuan Strok 冲程速度	3,000
<b>Tooth Spacing</b> Selang Gigi 牙齿间隔	18mm (11/16")
<b>Net Weight</b> Keberatan 净重	4.4kg (9.7lbs.)
<b>Power Supply Cord</b> Kabel Wayar 电源线	0.3m (0.98ft)

## EH7500SX 750mm (29-1/2")

### Petrol Hedge Trimmer

Pemangkas Tanaman Pagar Petrol  
汽油篱笆修剪机



CATALYTIC CONVERTER

- Blade teeth with 3 sharpened edges  
Bilah gigi dengan 3 ketajaman  
有3个锋利边缘的刀刃

Standard Equipment: Blade Cover, Socket Wrench, Hex Wrench



<b>Blade Length</b> Panjang Bilah 锯片长度	750mm (29-1/2")
<b>Displacement</b> Sesaran 排量	22.2mL
<b>Engine Power</b> Kuasa Enjin 发动机功率	0.68kW/ 1.0PS
<b>Fuel Tank Capacity</b> Tangki Minyak 油箱容量	0.4L
<b>Strokes Per Minute (SPM)</b> Kelajuan Strok 冲程速度	4390
<b>Tooth Spacing</b> Selang Gigi 牙齿间隔	35mm (1-3/8")
<b>Dimensions (L x W x H)</b> Dimensi 体积	1,150x323x212mm (45-1/4"x12-3/4"x8-3/8")
<b>Net Weight</b> Berat Bersih 净重	4.9kg (10.8lbs)

## EH6000W 600mm (23-5/8")

### Petrol Hedge Trimmer

Pemangkas Tanaman Pagar Petrol  
汽油篱笆修剪机



CATALYTIC CONVERTER

- The lightest 22.2cc petrol hedge trimmer with double-sided blade  
Trimmer petrol yang paling ringan dengan bilah dua sisi  
最轻的22.2cc双面刀片汽油绿篱机

Standard Equipment: Blade Cover, Socket Wrench, Hex Wrench



<b>Blade Length</b> Panjang Bilah 锯片长度	600mm (23-5/8")
<b>Displacement</b> Sesaran 排量	22.2mL
<b>Engine Power</b> Kuasa Enjin 发动机功率	0.68kW/ 1.0PS
<b>Fuel Tank Capacity</b> Tangki Minyak 油箱容量	0.4L
<b>Strokes Per Minute (SPM)</b> Kelajuan Strok 冲程速度	4390
<b>Tooth Spacing</b> Selang Gigi 牙齿间隔	35mm (1-3/8")
<b>Dimensions (L x W x H)</b> Dimensi 体积	1,119x262x216mm (44"x10-3/8"x8-1/2")
<b>Net Weight</b> Berat Bersih 净重	5kg (11lbs)

## EH5000W 500mm (19-3/4")

### Petrol Hedge Trimmer

Pemangkas Tanaman Pagar Petrol  
汽油篱笆修剪机



CATALYTIC CONVERTER

- Rotatable handle is convenient for various style operation  
Pemegang berputar mudah untuk pelbagai operasi  
可旋转的手柄方便各种操作

Standard Equipment: Blade Cover, Socket Wrench, Hex Wrench



<b>Blade Length</b> Panjang Bilah 锯片长度	500mm (19-3/4")
<b>Displacement</b> Sesaran 排量	22.2mL
<b>Engine Power</b> Kuasa Enjin 发动机功率	0.68kW/ 1.0PS
<b>Fuel Tank Capacity</b> Tangki Minyak 油箱容量	0.4L
<b>Strokes Per Minute (SPM)</b> Kelajuan Strok 冲程速度	4390
<b>Tooth Spacing</b> Selang Gigi 牙齿间隔	35mm (1-3/8")
<b>Dimensions (L x W x H)</b> Dimensi 体积	1,014x262x216mm (40"x10-3/8"x8-1/2")
<b>Net Weight</b> Berat Bersih 净重	4.8kg (10.5lbs)

Cordless  
Terasa Kosul Bebas

LED Flashlight  
Lampu Buah LED  
LED 照明灯

Vacuum Cleaner  
Pembersih Vakuum  
吸尘器

Drilling | Fastening  
Operasi | Pasang  
钻孔 | 紧固

Impact Drilling | Demolition  
Detah | Pencerai  
冲击钻孔 | 拆除加工

Cutting  
Pemotongan  
切割

Grinding | Sanding  
Pengamiran | Habis  
打磨 | 磨光

Sawing  
Gergaji  
锯切

Planing | Routing  
Pegyalan | Tumpang  
刨削 | 雕刻

Others  
Lain-lain  
其他

Outdoor Power Equipment  
Alatan Kerja Luar  
户外动力工具

Makita  
Makita

# OUTDOOR POWER EQUIPMENT

## HTR7610 750mm (29-1/2")

**Petrol Hedge Trimmer**  
Pemangkas Tanaman Pagar Petrol  
汽油篱笆修剪机



- **Wide-trigger control and soft grip for comfortable operation**  
Pencetus dan genggaman lembut untuk operasi yang selesa  
宽触发控制和柔软的握柄舒适操作

sementara stok masih ada 售完即止  
**WHILE STOCK LAST**



Standard Equipment: Blade Cover, Tool set



<b>Blade Length</b> Panjang Bilah 锯片长度	750mm (29-1/2")
<b>Displacement</b> Sesaran 排量	24.5mL
<b>Engine Power</b> Kuasa Enjin 发动机功率	0.73kW/ 0.99PS
<b>Fuel Tank Capacity</b> Tangki Minyak 油箱容量	0.6L
<b>Dimensions (L x W x H)</b> Dimensi 体积	1,041x280x258mm (41"x11"x10-1/8")
<b>Strokes Per Minute (SPM)</b> Kelajuan Strok 冲程速度	3,600
<b>Net Weight</b> Berat Bersih 净重	5.4kg (11.9lbs)

## HTR5600 560mm (22")

**Petrol Hedge Trimmer**  
Pemangkas Tanaman Pagar Petrol  
汽油篱笆修剪机



- **Very powerful 2-stroke engine**  
Enjin 2-strok yang berkuasa  
强大的二冲程引擎

sementara stok masih ada 售完即止  
**WHILE STOCK LAST**



Standard Equipment: Blade Cover, Tool set



<b>Blade Length</b> Panjang Bilah 锯片长度	560mm (22")
<b>Displacement</b> Sesaran 排量	24.5mL
<b>Engine Power</b> Kuasa Enjin 发动机功率	0.73kW/ 0.99PS
<b>Fuel Tank Capacity</b> Tangki Minyak 油箱容量	0.6L
<b>Tooth Spacing</b> Selang Gigi 牙齿间隔	28mm (1-1/8")
<b>Dimensions (L x W x H)</b> Dimensi 体积	840x246x225mm (33"x9-11/16"x8-7/8")
<b>Strokes Per Minute (SPM)</b> Kelajuan Strok 冲程速度	3,600
<b>Net Weight</b> Berat Bersih 净重	5.1kg (11.2lbs)

## EN4951SH 25.4mL 4-stroke

**Petrol Pole Hedge Trimmer**  
Pemangkas Tanaman Pagar Tinggi Petrol  
汽油高枝篱笆剪



- **Can be folded in the 180° position for easy transport and storage**  
Boleh dilipat di kedudukan 180 ° untuk memudahkan pengangkutan dan penyimpanan  
可以在180° 的位置折叠，便于运输和储存



Standard Equipment: Blade Cover, Socket Wrench, Hex Wrench, Band Assembly



<b>Displacement</b> Sesaran 排量	25.4mL
<b>Engine Power</b> Kuasa Enjin 发动机功率	0.77kW/ 1.1PS
<b>Fuel Tank Capacity</b> Tangki Minyak 油箱容量	0.6L
<b>Strokes Per Minute (SPM)</b> Kelajuan Strok 冲程速度	4,200
<b>Blade Length</b> Panjang Batang Gergaji 切割长度	490mm (19-1/4")
<b>Dimensions (L x W x H)</b> Dimensi 体积	2,050x221x241mm (80-1/2"x8-3/4"x9-1/2")
<b>Net Weight</b> Berat Bersih 净重	6.6kg (14.6lbs)

## PTR2500 24.5mL

**Petrol Pole Trimmer**  
Pemangkas Tanaman Pagar Tinggi Petrol  
汽油高枝篱笆剪



- **Very powerful 2-stroke engine**  
Enjin 2-strok yang berkuasa  
强大的二冲程引擎



Standard Equipment: Band Assembly, Accessory Bag, Tool Set, Wrench, Safety Goggles



<b>Displacement</b> Sesaran 排量	24.5mL
<b>Engine Power</b> Kuasa Enjin 发动机功率	0.73kW/ 0.99PS
<b>Fuel Tank Capacity</b> Tangki Minyak 油箱容量	0.65L
<b>Dimensions (L x W x H)</b> Dimensi 体积	2,400x350x220mm (94-1/2"x13-3/4"x8-5/8")
<b>Net Weight</b> Berat Bersih 净重	6.1kg (13.4lbs)

## EB7660TH 75.6mL 4-Stroke

**Petrol Blower**  
Mesin Peniup Petrol  
背负式汽油吹风机



- **Powerful fuel efficient 75.6mL MM4 commercial duty engine**  
Enjin MM4 komersial 75.6mL yang cekap  
强力工业用途四冲程吹风机



Standard Equipment: Oil (195532-1), Socket Wrench, Driver, Flexible Pipe, Swivel Pipe, Hose Clamp, End Nozel, Flat Nozzle, Long Pipe, Short Pipe, Cable Holder, Accessory Bag



<b>Displacement</b> Sesaran 排量	75.6mL
<b>Power Rating</b> Kuasa 额定功率	3.0kW (4.1PS)
<b>Max Air Volume</b> Isipadu Angin Maksimum 最大风量	20m³/min (706CFM)
<b>Max Air Velocity</b> Velositi Angin Maksimum 最大风速	92m/s (205MPH)
<b>Fuel Tank Capacity</b> Tangki Minyak 油箱容量	1.9L (64oz.)
<b>No Load Speed (RPM)</b> Kelajuan Tanpa Beban 回转速	2,800 - 7,200
<b>Max Torque</b> Pemutaran Tenaga Maksimum 最大扭矩	4.7N·m
<b>Dimensions (L x W x H)</b> Dimensi 体积	332x460x480mm (13-1/8"x18-1/8"x18-7/8")
<b>Net Weight</b> Berat Bersih 净重	11.9 - 12.1kg (26.2 - 26.7lbs.)

Cordless  
Tenggakord 无绳式

LED Flashlight  
Lampu Suka LED  
LED照明灯

Vacuum Cleaner  
Pembersih Vakuam  
吸尘器

Drilling / Fastening  
Cairus / Pengikat  
钻孔 / 紧固

Impact Drilling / Demolition  
Cairus / Pemusnah  
冲击钻孔 / 拆毁施工

Cutting  
Pemotong  
切割

Grinding / Sanding  
Pengkilan / Pasir  
研磨 / 打磨

Sawing  
Cergas  
锯切

Planing / Routing  
Pecutan / Tanggung  
刨削 / 雕刻

Others  
Lain-lain  
其他

Outdoor Power Equipment  
Alatan Kaji Luar  
园林工具



# OUTDOOR POWER EQUIPMENT

Cordless  
Terdapat Model Cordless

LED Flashlight  
Lampu Senter LED  
LEDMENYALIT

Vacuum Cleaner  
Pembersih Vakuum  
真尘机

Drilling / Fastening  
Drill / Pemasangan  
钻孔 / 紧固

Impact Drilling / Demolition  
Drill / Pemasangan  
钻孔 / 拆除加工

Cutting  
Pemotongan  
切割

Grinding / Sanding  
Pengamiran / Habisan  
打磨 / 打磨

Sawing  
Dempul  
锯切

Planing / Routing  
Pengamiran / Tumpang  
磨削 / 磨削

Others  
Lain-lain  
其他

Outdoor Power Equipment  
Alat-alat Tenaga Listrik  
户外动力设备

Makita  
Makita

## EB5300TH 52.5mL 4-Stroke

**Petrol Blower**  
Mesin Peniup Petrol  
背负式汽油吹风机



- Heavy duty anti-vibration mounts between frame and engine for improved operator comfort  
Bertugas berat dan anti getaran  
强力、低振动和舒适的设计

Standard Equipment: Oil (198279-6), Box Wrench, Driver, Flexible Pipe, Swivel Pipe, Hose Clamp, End Nozzle, Flat Nozzle, Long Pipe, Short Pipe, Cable Holder, Accessory Bag



VIDEO CLIP  
Models and specs may vary by country



<b>Displacement</b> Sesaran 排量	52.5mL
<b>Power Rating</b> Kuasa 额定功率	1.8kW (2.5PS)
<b>Max Air Volume</b> Isipadu Angin Maksimum 最大风量	15m <sup>3</sup> /min (516CFM)
<b>Max Air Velocity</b> Velositi Angin Maksimum 最大风速	98m/s (220MPH)
<b>Fuel Tank Capacity</b> Tangki Minyak 油箱容量	1.8L (61oz.)
<b>No Load Speed (RPM)</b> Kelajuan Tanpa Beban 回转速数	2,800 - 6,400
<b>Max Torque</b> Pemutaran Tenaga Maksimum 最大扭力	3.0N·m
<b>Dimensions (L x W x H)</b> Dimensi 体积	320x450x475mm (12-5/8"x17-3/4"x18-3/4")
<b>Net Weight</b> Berat Bersih 净重	8.9kg (19.7lbs.)

## BHX2500 24.5mL 4-stroke

**Petrol Blower**  
Mesin Peniup Petrol  
汽油吹风机



- 4-stroke engine requires no fuel mix. 4-stroke for low noise and low emission  
Enjin 4 strok tidak perlu campuran minyak, bunyi rendah dan perlepasan asap rendah  
四冲程引擎，无需混合燃料，低噪音，无排气

Standard Equipment: Pipe, Nozzle, Socket Wrench



<b>Displacement</b> Sesaran 排量	24.5mL
<b>Power Rating</b> Kuasa 额定功率	0.81kW
<b>Max Air Volume</b> Isipadu Angin Maksimum 最大风量	10.1m <sup>3</sup> /min (356CFM)
<b>Max Air Velocity</b> Velositi Angin Maksimum 最大风速	65m/s (145MPH)
<b>Fuel Tank Capacity</b> Tangki Minyak 油箱容量	0.52L (17.6oz.)
<b>No Load Speed (RPM)</b> Kelajuan Tanpa Beban 回转速数	3,500 - 7,800
<b>Dimensions (L x W x H)</b> Dimensi 体积	350x231x368mm (13.8"x9.1"x14.5")
<b>Net Weight</b> Berat Bersih 净重	4.5kg (9.8lbs)

## Powerful spray range up to 16m (52ft) horizontally

Penyembur yang berkuasa tinggi boleh menyembur sampai 16m (52ft) secara mendatar 强力喷雾系列，距离长达 16m (52英尺)

**Mosquito Spray Nozzles** Part No. 196499-6 (Optional Accessories)

For users consider to reduce risk of getting disease from mosquito, the best option is using Makita Petrol Mist Blower with mosquito spray nozzle accessories.

**Muncung penyembur untuk mengurangkan nyamuk**  
Untuk pengguna yang ingin mengurangkan risiko jangkitan dari nyamuk yang berpenyakit, pilihan yang terbaik adalah menggunakan Petrol Penyembur Makita dengan aksesori muncung penyembur nyamuk.

为降低蚊子疾病感染的风险，Makita 汽油喷雾机与蚊子喷嘴配件的搭配是最佳选择。

## PM7650H 75.6mL 4-stroke

**Mist Blower**  
Penyembur Petrol  
汽油喷雾器



**Mosquito Spray Nozzles**  
Part No. 196499-6 (Optional Accessories)

- Excellent spray range performance up to 16m (52 ft) horizontally  
Semburan yang berprestasi tinggi sehingga 16m (52 kaki) secara mendatar  
优秀的喷射性能水平高达 16m (52英尺)

Standard Equipment: Hand Strap, Screwdriver, Diffusion Cover, Hose Clamp, Flexible Pipe, Straight Pipe



<b>Displacement</b> Sesaran 排量	75.6mL
<b>Fuel Tank Capacity</b> Tangki Minyak 油箱容量	1.8L
<b>Max Air Volume</b> Isipadu Angin Maksimum 最大风量	14.1m <sup>3</sup> /min (497CFM) The velocity of the wind (w/o blower pipes) 85m/s
<b>Dimensions (L x W x H)</b> Dimensi 体积	420x440x595mm (16-1/2"x17-1/4"x23-1/2")
<b>Net Weight</b> Keberatan 净重	13.9kg (30.6lbs)

# OUTDOOR POWER EQUIPMENT

## ELM4121 410mm (16-1/8")

### Electric Lawn Mower

Mesin Pemotong Rumput  
电手推割草机

- **Robust steel cutting deck for increased durability**  
Dek keluli memotong untuk meningkat ketahanan  
钢制切割台提高其耐用性

Standard Equipment: Blade, Wrench, Mulch Plug



<b>Continuous Rating Input</b> Input Kuasa Berterusan 额定输入功率	1,600W
<b>Hole Diameter</b> Diameter Lubang 孔直径	8mm (5/16")
<b>Cutting Width</b> Lebar Keratan 切割宽度	410mm (16-1/8")
<b>Cutting Height</b> Ketinggian Pemotongan 切割高度	20 - 75mm (13/16" - 2-15/16")
<b>No Load Speed (RPM)</b> Kelajuan Tanpa Beban 回转数	3,400
<b>Recommended mowing area up to</b> Julat Memotong yang Disyorkan 推荐的割草范围	600m <sup>2</sup>
<b>Grass Box Capacity</b> Kapasiti Kotak Rumput 草箱容量	50L
<b>Wheel Size</b> Saiz Roda 轮片尺寸	Front / Rear: 156 / 200mm (6-1/8 / 7-7/8")
<b>Dimensions (L x W x H)</b> Dimensi 体积	1,465x530x905-1,135mm (57-3/4"x20-7/8"x35-5/8" - 44-3/4")
<b>Net Weight</b> Berat Bersih 净重	17.5 - 19.1kg (38.6 - 42.1lbs.)

## ELM3720 370mm (14-1/2")

### Electric Lawn Mower

Mesin Pemotong Rumput  
电手推割草机

- **Stays upright for easy maintenance and cleaning**  
Penyelenggaraan dan pembersihan lebih mudah  
简单维护和清洁

Standard Equipment: Blade, Wrench



<b>Continuous Rating Input</b> Input Kuasa Berterusan 额定输入功率	1,400W
<b>Hole Diameter</b> Diameter Lubang 孔直径	8mm (5/16")
<b>Cutting Width</b> Lebar Keratan 切割宽度	370mm (14-1/2")
<b>Cutting Height</b> Ketinggian Pemotongan 切割高度	20 - 55mm (13/16" - 2-3/16")
<b>No Load Speed (RPM)</b> Kelajuan Tanpa Beban 回转数	3,400
<b>Recommended mowing area up to</b> Julat Memotong yang Disyorkan 推荐的割草范围	500m <sup>2</sup>
<b>Grass Box Capacity</b> Kapasiti Kotak Rumput 草箱容量	40L
<b>Wheel Size</b> Saiz Roda 轮片尺寸	Front / Rear: 139 / 178mm (5-1/2 / 7")
<b>Dimensions (L x W x H)</b> Dimensi 体积	1,330x415x890-1,120mm (52-3/8"x16-3/8"x35" - 44")
<b>Net Weight</b> Berat Bersih 净重	11.6kg (25.6lbs.)

## ELM3711X 370mm (14-1/2")

### Electric Lawn Mower

Mesin Pemotong Rumput  
电手推割草机

- **Silent and NO emission**  
Senyap dan tanpa perlepasan asap  
低噪音, 无排气

Standard Equipment: Blade



<b>Continuous Rating Input</b> Input Kuasa Berterusan 额定输入功率	1,400W
<b>Cutting Width</b> Lebar Keratan 切割宽度	370mm (14-1/2")
<b>Cutting Height</b> Ketinggian Pemotongan 切割高度	20,40,55mm (13/16, 1-9/16, 2-3/16")
<b>No Load Speed (RPM)</b> Kelajuan Tanpa Beban 回转数	2,900
<b>Recommended Mowing Area up to</b> Julat memotong yang disyorkan 推荐的割草范围	500m <sup>2</sup>
<b>Grass Box Capacity</b> Kapasiti Kotak Rumput 草箱容量	35L
<b>Dimensions (L x W x H)</b> Dimensi 体积	662x412x312mm (26"x16-1/2"x12-5/8")
<b>Net Weight</b> Berat Bersih 净重	14.8kg (32.6lbs)

## ELM3320 330mm (13")

### Electric Lawn Mower

Mesin Pemotong Rumput  
电手推割草机

- **Stays upright for easy maintenance and cleaning**  
Penyelenggaraan dan pembersihan lebih mudah  
简单维护和清洁

Standard Equipment: Blade, Wrench



<b>Continuous Rating Input</b> Input Kuasa Berterusan 额定输入功率	1,200W
<b>Hole Diameter</b> Diameter Lubang 孔直径	8mm (5/16")
<b>Cutting Width</b> Lebar Keratan 切割宽度	330mm (13")
<b>Cutting Height</b> Ketinggian Pemotongan 切割高度	20 - 55mm (13/16" - 2-3/16")
<b>No Load Speed (RPM)</b> Kelajuan Tanpa Beban 回转数	3,400
<b>Recommended mowing area up to</b> Julat Memotong yang Disyorkan 推荐的割草范围	400m <sup>2</sup>
<b>Grass Box Capacity</b> Kapasiti Kotak Rumput 草箱容量	30L
<b>Wheel Size</b> Saiz Roda 轮片尺寸	Front / Rear: 139 / 178mm (5-1/2 / 7")
<b>Dimensions (L x W x H)</b> Dimensi 体积	1,230x380x870-1,110mm (48-1/2"x15"x34-1/4" - 43-3/4")
<b>Net Weight</b> Berat Bersih 净重	10.2kg (22.5lbs.)

## ELM3311X 330mm (13")

### Electric Lawn Mower

Mesin Pemotong Rumput  
电手推割草机

- **Wheels tucked under body to enhance performance**  
Roda bawah badan mesin untuk meningkatkan prestasi  
轮子隐藏在机身下提高性能



<b>Continuous Rating Input</b> Input Kuasa Berterusan 额定输入功率	1,100W
<b>Cutting Width</b> Lebar Keratan 切割宽度	330mm (13")
<b>Cutting Height</b> Ketinggian Pemotongan 切割高度	20,40,55mm (13/16, 1-9/16, 2-3/16")
<b>No Load Speed (RPM)</b> Kelajuan Tanpa Beban 回转数	2,900
<b>Recommended Mowing Area up to</b> Julat memotong yang disyorkan 推荐的割草范围	400m <sup>2</sup>
<b>Grass Box Capacity</b> Kapasiti Kotak Rumput 草箱容量	27L
<b>Dimensions (L x W x H)</b> Dimensi 体积	621x376x312mm (24-1/2"x14-3/4"x12-1/4")
<b>Net Weight</b> Berat Bersih 净重	13.0kg (28.7lbs)

Cordless  
Tapis Kord 0.0.0.0.

LED Flashlight  
Lampu Suluh LED  
LED 闪光灯

Vacuum Cleaner  
Pembersih Vakuam  
吸尘器

Drilling / Fastening  
Cetus / Pengikat  
钻孔 / 紧固

Impact Drilling / Demolition  
Cetus / Patahkan  
冲击钻孔 / 拆毁施工

Cutting  
Pemotong  
切割

Grinding / Sanding  
Pengkilan / Patahkan  
研磨 / 打磨

Sawing  
Cetus  
锯切

Planing / Routing  
Pegyalan / Tanggung  
刨削 / 雕刻

Others  
Lain-lain  
其他

Outdoor Power Equipment  
Alatan Keping Luar  
户外动力工具

Thakita  
T.M.T.

Thakita  
T.M.T.

# OUTDOOR POWER EQUIPMENT

Cordless  
Tanpa Kawat / 无线式

LED Flashlight  
Lampu Senter LED  
LED 照明灯

Vacuum Cleaner  
Pembersih Vakuum  
吸尘器

Drilling / Fastening  
Oporol / Pengencat  
钻孔 / 紧固

Impact Drilling / Demolition  
Dobrak / Pencah  
冲击钻孔 / 拆除加工

Cutting  
Pemotong  
切割机

Grinding / Sanding  
Pengamiran / Tumbuk  
打磨 / 磨削

Sawing  
Dagang  
锯切

Planing / Routing  
Pencetakan / Tumpang  
刨削 / 雕刻

Others  
Lain-lain  
其他

Outdoor Power Equipment  
Alat-alat Kertala Luar  
园林 / 户外

Makita  
マキタ

## PLM5120N2 | PLM5120 510mm (20")

**Petrol Lawn Mower**  
Mesin Pemotong Rumput Petrol  
汽油手推割草机

- 4-stroke engine requires no fuel mix  
Enjin 4 strok tidak perlu campuran minyak  
四冲程引擎，无需混合燃料

PLM5120N2 ▶



PLM5120  
Sembarang stok  
Model dan spesifikasi  
may vary by country  
**WHILE STOCK LAST**

Standard Equipment: Blade, Box Wrench,  
Side Discharge Channell



<b>Engine</b> Enjin 发动机	B&S625E R/S, 150mL PLM5120N2 B&S625E, 190mL PLM5120
<b>Engine Power</b> Kuasa Enjin 发动机功率	2.2kW/ N/A PS
<b>Cutting Width</b> Lebar Keratan 切割宽度	510mm (20")
<b>Cutting Height</b> Ketinggian Pemotongan 切割高度	25 - 70mm (1" - 2-3/4")
<b>No Load Speed (RPM)</b> Kelajuan Tanpa Beban 回转速	2,800
<b>Recommended Mowing Area up to</b> Julat Memotong yang Disyorkan 推荐的割草范围	1,500m <sup>2</sup> PLM5120N2 2,200m <sup>2</sup> PLM5120
<b>Fuel Tank Capacity</b> Tangki Minyak 油箱容量	0.8L (N/A oz.) PLM5120N2 1.0L (N/A oz.) PLM5120
<b>Oil Tank Capacity</b> Kapasiti Tangki Minyak 润滑油箱	0.47L (N/A oz.) PLM5120N2
<b>Dimensions (L x W x H)</b> Dimensi 体积	850x560x375mm (33-1/2"x22"x14-3/4") PLM5120N2 800x550x380mm (31-1/2"x21-5/8"x15") PLM5120
<b>Net Weight</b> Berat Bersih 净重	25.5kg (57.3lbs.) PLM5120N2 28kg (61.7lbs.) PLM5120

## PLM4620N2 460mm (18-1/8")

**Petrol Lawn Mower**  
Mesin Pemotong Rumput Petrol  
汽油手推割草机

- Brake for maximum productivity and increased operator safety  
Brek untuk produktiviti maksimum dan keselamatan pengguna  
电刹车器增加使用者的安全



Standard Equipment: Blade, Box Wrench, Mulch plug



<b>Engine</b> Enjin 发动机	B&S625E R/S, 150mL
<b>Engine Power</b> Kuasa Enjin 发动机功率	2.2kW/ N/A PS
<b>Cutting Width</b> Lebar Keratan 切割宽度	460mm (18-1/8")
<b>Cutting Height</b> Ketinggian Pemotongan 切割高度	25 - 70mm (1" - 2-3/4")
<b>No Load Speed (RPM)</b> Kelajuan Tanpa Beban 回转速	2,800
<b>Recommended Mowing Area up to</b> Julat Memotong yang Disyorkan 推荐的割草范围	1,200m <sup>2</sup>
<b>Grass Box Capacity</b> Kapasiti Kotak Rumput 草箱容量	60L
<b>Fuel Tank Capacity</b> Tangki Minyak 油箱容量	Fuel: 0.8L (N/A oz.) Oil: 0.47L (N/A oz.)
<b>Dimensions (L x W x H)</b> Dimensi 体积	800x540x400mm (31-1/2"x21-1/4"x15-3/4")
<b>Net Weight</b> Berat Bersih 净重	27.6kg (60.9lbs.)

## EK7651H / X1 355mm (14")

**Power Cutter**  
Pemotong Berkuasa  
汽油切断机



- Save cost of the power cutter with fuel savings alone  
Kos operasi yang rendah  
节省燃油



VIDEO CLIP  
Models and specs may vary by country

- X1: Come with Diamond Wheel (B-13465), Oil (195532-D)



<b>Wheel Diameter</b> Diameter Roda 轮片直径	355mm (14")
<b>Engine</b> Enjin 发动机	75.6mL
<b>Max Cutting Depth</b> Kedalaman Pemotongan Maksimum 最大切割深度	122mm (4-13/16")
<b>No Load Speed (RPM)</b> Kelajuan Tanpa Beban 回转速	4,300
<b>Circumferential Speed</b> Kelajuan 圆周速度	80m/s
<b>Engine Power</b> Kuasa Enjin 发动机功率	3.0kW/ 4.1PS
<b>Fuel Tank Capacity</b> Tangki Minyak 油箱容量	1.1L
<b>Dimensions (L x W x H)</b> Dimensi 体积	780x310x455mm (30-3/4"x12-1/4"x17-7/8")
<b>Net Weight</b> Berat Bersih 净重	14.2kg (31.3lbs)

## EK7301 355mm (14")

**Power Cutter**  
Pemotong Berkuasa  
汽油切断机



- High performance and powerful Engine  
Enjin berprestasi tinggi dan berkuasa  
高性能和强力的引擎



WHILE STOCK LAST  
可圖發售 即止

Standard Equipment: Cutting Disc, Socket Wrench



<b>Wheel Diameter</b> Diameter Roda 轮片直径	355mm (14")
<b>Engine</b> Enjin 发动机	73mL
<b>Max Cutting Depth</b> Kedalaman Pemotongan Maksimum 最大切割深度	122mm (4-13/16")
<b>Circumferential Speed</b> Kelajuan 圆周速度	80m/s
<b>Engine Power</b> Kuasa Enjin 发动机功率	3.8kW/ 5.1PS
<b>Fuel Tank Capacity</b> Tangki Minyak 油箱容量	1.1L
<b>Dimensions (L x W x H)</b> Dimensi 体积	770x290x370mm (30-1/4"x11-3/8"x14-1/2")
<b>Net Weight</b> Berat Bersih 净重	10.1kg (22.3lbs)

## EK6101 355mm (14")

**Power Cutter**  
Pemotong Berkuasa  
汽油切断机



- Smaller hub and drive wheel for increases maximum cutting depth  
Hab kecil dan roda pemacu untuk meningkatkan pemotongan kedalaman maksimum  
较小的轮毂和驱动轮可增加最大切割深度



Standard Equipment: Cutting Disc, Wrenches, Screwdriver



<b>Wheel Diameter</b> Diameter Roda 轮片直径	355mm (14")
<b>Engine</b> Enjin 发动机	61mL
<b>Max Cutting Depth</b> Kedalaman Pemotongan Maksimum 最大切割深度	130mm (5-1/8")
<b>No Load Speed (RPM)</b> Kelajuan Tanpa Beban 回转速	4,400
<b>Circumferential Speed</b> Kelajuan 圆周速度	80m/s
<b>Engine Power</b> Kuasa Enjin 发动机功率	3.2kW/ 4.4PS
<b>Fuel Tank Capacity</b> Tangki Minyak 油箱容量	0.7L
<b>Overall Length</b> Dimensi 体积	730mm (28-3/4")
<b>Net Weight</b> Berat Bersih 净重	8.8kg (19.4lbs)

# OUTDOOR POWER EQUIPMENT



**VARIOUS OPTIONS**  
Pelbagai pilihan  
各种选择

- Trigger gun set  
Part No. 197842-2
- Variable nozzle set  
Part No. 197822-8
- Cyclone jet nozzle set  
Part No. 197824-4
- Cyclone guard set  
Part No. 197864-2
- Variospray lance set  
Part No. 197876-5
- Under body spray lance set  
Part No. 198909-9
- Extension pipe set  
Part No. 197870-7
- Rotating brush set  
Part No. 197831-7
- Wash brush set  
Part No. 197828-6
- Foam nozzle set  
Part No. 197886-2
- Pipe cleaning hose  
Part No. 197837-5
- Self-suction hose set  
Part No. 197873-1

Cordless  
Type: Kord 30.6L

LED Flashlight  
Lampu Suka LED  
LED 30.6L

Vacuum Cleaner  
Pembersih Vakum  
30.6L

Drilling / Fastening  
Cairul / Pasang  
30.6L / 30.6L

Impact Drilling / Demolition  
Cairul / Hancurkan  
30.6L / 30.6L

Cutting  
Pemotong  
30.6L

Grinding / Sanding  
Penghalut / Pasir  
30.6L / 30.6L

Sawing  
Cairul  
30.6L

Planing / Routing  
Mecuk / Tampung  
30.6L / 30.6L

Others  
Lain-lain  
30.6L

Outdoor Power Equipment  
Alatan Kuasa Luar  
30.6L / 30.6L



# OUTDOOR POWER EQUIPMENT

## HW1300

### High Pressure Washer

Pembersih Tekanan Tinggi  
高压清洗机



- **Eco-friendly for reduced water**  
Mesra alam dengan pengurangan kegunaan air  
环保与减少用水量

**Standard Equipment:** Trigger Gun, Vario-Power Spray Lance, Cyclone jet nozzle, Detergent Bottle, Cleaner Pin, Coupling Sleeve, High Pressure Hose 10m, Water Hose Connector, Foam Nozzle, Connector



<b>Continuous Rating Input</b> Input Kuasa Berterusan 额定输入功率	1,800W
<b>Max Pressure</b> Tekanan Maksimum 最大水压	13MPa (130bar, 1,885PSI)
<b>Max Flow Rate</b> Aliran Air Maksimum 最大流量	420L/h
<b>Max Input Temperature</b> Ketahanan Suhu Air 最大输入温度	40°C (104°F)
<b>High Pressure Hose Length</b> Hos Tekanan 高压软管长度	10m (33ft.)
<b>Dimensions (L x W x H)</b> Dimensi 体积	292x358x830mm (11-1/2"x14-1/8"x32-3/4")
<b>Net Weight</b> Berat Bersih 净重	12.7kg (28.0lbs.)
<b>Power Supply Cord</b> Kabel Wayer 电源线	5.0m (16.4ft.)

## HW1200

### High Pressure Washer

Pembersih Tekanan Tinggi  
高压清洗机



- **Uses up to 80% less water than a garden hose while delivering up to 50X the pressure**  
Memberikan tekanan 50 kali ganda lebih daripada hos biasa dan menjimatkan 80% penggunaan air berbanding dengan hos biasa  
用水量比园艺胶管少80%，同时可提供高达50倍的水压力

**Standard Equipment:** Trigger Gun, Vario-Power Spray Lance, Cyclone jet nozzle, Detergent Bottle, Cleaner Pin, Coupling Sleeve, High Pressure Hose 10m, Water Hose Connector, Foam Nozzle, Connector



<b>Continuous Rating Input</b> Input Kuasa Berterusan 额定输入功率	1,800W
<b>Max Pressure</b> Tekanan Maksimum 最大水压	12MPa (120bar, 1,740PSI)
<b>Max Flow Rate</b> Aliran Air Maksimum 最大流量	420L/h
<b>Max Input Temperature</b> Ketahanan Suhu Air 最大输入温度	40°C (104°F)
<b>High Pressure Hose Length</b> Hos Tekanan 高压软管长度	10m (33 ft.)
<b>Dimensions (L x W x H)</b> Dimensi 体积	292x358x830mm (11-1/2"x14-1/8"x32-3/4")
<b>Net Weight</b> Berat Bersih 净重	11.0kg (24.3lbs.)
<b>Power Supply Cord</b> Kabel Wayer 电源线	5.0m (16.4ft.)

## HW121

### High Pressure Washer

Pembersih Tekanan Tinggi  
高压清洗机



- **Made for frequent usage on larger, dirty or very dirty areas**  
Sesuai untuk pembersihan kerap di tempat yang luas dan kotoran yang degil  
适用于清洗较大的面积和极度肮脏的地方

## HW102

### High Pressure Washer

Pembersih Tekanan Tinggi  
高压清洗机



- **Lightweight and compact power washer for home**  
Ringan dan padat, sesuai untuk kegunaan rumah  
轻量家用高压清洗机



<b>Continuous Rating Input</b> Kuasa 额定输入功率	2,100W
<b>Max Pressure</b> Tekanan Maksimum 最大水压	13MPa (130bar, 1,885PSI)
<b>Max Flow Rate</b> Aliran Air Maksimum 最大流量	390L/h
<b>Motor Type</b> Enjin 马达类型	Induction
<b>Max Input Temperature</b> Ketahanan Suhu Air 最大输入温度	50°C (122°F)
<b>High Pressure Hose Length</b> Hos Tekanan 高压软管长度	8m (26.3ft.)
<b>Net Weight</b> Berat Bersih 净重	17.8kg (39.2lbs.)

<b>Continuous Rating Input</b> Kuasa 额定输入功率	1,300W
<b>Max Pressure</b> Tekanan Maksimum 最大水压	10MPa (100bar, 1,450PSI)
<b>Max Flow Rate</b> Aliran Air Maksimum 最大流量	360L/h
<b>Motor Type</b> Enjin 马达类型	Universal
<b>Max Input Temperature</b> Ketahanan Suhu Air 最大输入温度	50°C (122°F)
<b>High Pressure Hose Length</b> Hos Tekanan 高压软管长度	5m (16.4ft.)
<b>Net Weight</b> Berat Bersih 净重	5.8kg (12.8lbs.)

## EW3051H | EW2051H 169mL 4-stroke

### Pump

Pam  
汽油水泵



- **4-stroke for low noise and low emission**  
4 strok untuk bunyi rendah dan pelepasan asap yang rendah  
四冲程低噪音，低排气

**Standard Equipment:** Hose coupling, Hose band, Strainer, Hex Wrench



<b>Displacement</b> Sesaran 排量	169mL
<b>Suction &amp; Discharge Diameter</b> Sedutan dan Diameter Paip 吸管与排管直径	80mm (3") EW3051H 50mm (2") EW2051H
<b>Max Pumping Capacity</b> Kapasiti Pemomputan Maksimum 最大泵水能力	1,000L/min (33,800gal/min) EW3051H 700L/min (23,700gal/min) EW2051H
<b>Total Head</b> Mesin 机头	23m (75ft)
<b>Fuel Tank Capacity</b> Tangki Minyak 油箱容量	3.2L
<b>Max Suction Head</b> Mesin Sedutan 吸头	8m (26ft)
<b>Engine Model</b> Enjin 发动机	EX17 EW3051H EX16 EW2051H
<b>Dimensions (L x W x H)</b> Dimensi 体积	527x368x417mm (20-3/4"x14-1/2"x16-3/8")
<b>Net Weight</b> Berat Bersih 净重	26.1kg (57.6lbs) EW3051H 24.9kg (54.9lbs) EW2051H





**Cordless**  
Terdapat Ford 18V DC

**LED Flashlight**  
Lampu Suluah LED  
LED 照燈

**Vacuum Cleaner**  
Pembersih Vacuum  
吸尘器

**Drilling | Fastening**  
Gerudi | Pengikat  
钻孔 | 紧固

**Impact Drilling | Demolition**  
Gerudi | Pemecah  
石工钻孔 | 凿裂加工

**Cutting**  
Pemotong  
切割

**Grinding | Sanding**  
Pengisar | Pelsih  
研磨 | 砂磨

**Sawing**  
Gergaji  
锯切

**Planing | Routing**  
Pergesam | Tanggam  
刨削 | 雕刻

**Others**  
Lain-lain  
其他

**Outdoor Power Equipment**  
Alatan Kerja Luar  
园机·户外

**M6501G** 6.5mm (1/4")

85

**High Speed Drill**Gerudi Kelajuan Tinggi  
高速钻

- **Ideal for drilling smaller holes in wood & steel**  
Sesuai untuk pengerudian lubang lebih kecil pada bahan kayu atau logam  
适用于木材和钢材上钻孔



Standard Equipment: Chuck Key

**Continuous Rating Input**

Input Kuasa Berterusan 额定输入功率

230W

**Capacity**

Kapasiti 能力

Steel: 6.5mm (1/4")

Wood: 9mm (11/32")

**No Load Speed (RPM)**

Kelajuan Tanpa Beban 回转数

0 - 4,500

**Dimensions (L x W x H)**

Dimensi 体积

203x63x171mm

(8"x2-1/2"x6-3/4")

**Net Weight**

Berat Bersih 净重

0.95kg (2.1lbs)

**Power Supply Cord**

Kabel Wayar 电源线

2.0m (6.6ft.)

**M0600G** 10mm (3/8")

64

**Drill**Gerudi  
电钻

- **Powerful 350W motor for continuous operation**  
Motor berkuasa 350W untuk operasi berterusan  
强力350W马达可持续运作



Standard Equipment: Chuck Key, Chuck Key Holder

**Continuous Rating Input**

Input Kuasa Berterusan 额定输入功率

350W

**Capacity**

Kapasiti 能力

Steel: 10mm (3/8")

Wood: 20mm (13/16")

**No Load Speed (RPM)**

Kelajuan Tanpa Beban 回转数

0 - 3,000

**Dimensions (L x W x H)**

Dimensi 体积

230x66x176mm

(9"x2-5/8"x6-15/16")

**Net Weight**

Berat Bersih 净重

1.2kg (2.6lbs)

**Power Supply Cord**

Kabel Wayar 电源线

2.0m (6.6ft.)

**M6001G** 10mm (3/8")

85

**Drill**Gerudi  
电钻

- **Powerful 450W motor for continuous operation**  
Motor berkuasa 450W untuk operasi berterusan  
强力450W马达可持续运作



Standard Equipment: Chuck Key

**Continuous Rating Input**

Input Kuasa Berterusan 额定输入功率

450W

**Capacity**

Kapasiti 能力

Steel: 10mm (3/8")

Wood: 25mm (1")

**No Load Speed (RPM)**

Kelajuan Tanpa Beban 回转数

0 - 3,000

**Dimensions (L x W x H)**

Dimensi 体积

229x64x175mm

(9"x2-1/2"x6-7/8")

**Net Weight**

Berat Bersih 净重

1.3kg (2.9lbs)

**Power Supply Cord**

Kabel Wayar 电源线

2.0m (6.6ft.)

**M6200G** 13mm (1/2")

303

**Drill**Gerudi  
电钻

- **Powerful 800W motor with variable speed for improved mixing and drilling performance**  
Motor berkuasa 800W dengan Pilihan kawalan kelajuan berubah untuk prestasi pencampuran dan pengerudian yang lebih baik  
强力800W马达配备变速控制功率提高混合和钻孔性能



Standard Equipment: Chuck Key, Top Grip

**Continuous Rating Input**

Input Kuasa Berterusan 额定输入功率

800W

**Capacity**

Kapasiti 能力

Steel: 13mm (1/2")

Wood: 36mm (1-7/16")

**No Load Speed (RPM)**

Kelajuan Tanpa Beban 回转数

0 - 700

**Dimensions (L x W x H)**

Dimensi 体积

267x86x388mm

(10-1/2"x3-3/8"x15-1/4")

**Net Weight**

Berat Bersih 净重

2.7kg (6.0lbs.)

**Power Supply Cord**

Kabel Wayar 电源线

2.0m (6.6ft.)

**M6600XG**

303

**Mixer**Pengadun  
搅拌机

- **Powerful 800W motor for improved mixing and drilling performance**  
Motor berkuasa 800W untuk prestasi pencampuran dan pengerudian yang lebih baik  
强力800W马达提高混合和钻孔性能



Come with



Mixing Blade 165

Standard Equipment: Mixing Blade, Shaft, Top Grip, Wrenches

**Continuous Rating Input**

Input Kuasa Berterusan 额定输入功率

800W

**Blade Diameter**

Diameter Bilah 锯片直径

165mm (6-1/2")

**No Load Speed (RPM)**

Kelajuan Tanpa Beban 回转数

0 - 700

**Dimensions (L x W x H)**

Dimensi 体积

280x86x388mm

(11"x3-3/8"x15-1/4")

**Net Weight**

Berat Bersih 净重

2.6kg (5.7lbs.)

**Power Supply Cord**

Kabel Wayar 电源线

2.0m (6.6ft.)



**M8103G** 13mm (1/2") 85

**Hammer Drill**

Gerudi Tukul  
冲击电钻



- 2-mode operation for hammering with rotation or rotation only  
Operasi 2 mod, penukulan dengan putaran atau hanya putaran  
2档模式变换, 旋转并锤击或仅旋转

Standard Equipment: Chuck Key, Side Grip, Chuck Key Holder



<b>Continuous Rating Input</b> Input Kuasa Berterusan 额定输入功率	430W
<b>Capacity</b> Kapasiti 能力	Concrete: 13mm (1/2") Steel: 13mm (1/2") Wood: 18mm (11/16")
<b>Impacts Per Minute (IPM)</b> Impak Per Minit 冲击数	0 - 33,000
<b>No Load Speed (RPM)</b> Kelajuan Tanpa Beban 回转数	0 - 3,000
<b>Dimensions (L x W x H)</b> Dimensi 体积	255x72x193mm (10"x2-13/16"x7-5/8")
<b>Net Weight</b> Berat Bersih 净重	1.8kg (3.9lbs)
<b>Power Supply Cord</b> Kabel Wayar 电源线	2.0m (6.6ft)

**M8081G** 16mm (5/8") 85

**Hammer Drill**

Gerudi Tukul  
冲击电钻



- 2-mode operation for hammering with rotation or rotation only  
Operasi 2 mod, penukulan dengan putaran atau hanya putaran  
2档模式变换, 旋转并锤击或仅旋转

Standard Equipment: Chuck Key, Side Grip



<b>Continuous Rating Input</b> Input Kuasa Berterusan 额定输入功率	500W
<b>Capacity</b> Kapasiti 能力	Concrete: 16mm (5/8") Steel: 13mm (1/2") Wood: 20mm (13/16")
<b>Impacts Per Minute (IPM)</b> Impak Per Minit 冲击数	0 - 48,000
<b>No Load Speed (RPM)</b> Kelajuan Tanpa Beban 回转数	0 - 3,200
<b>Dimensions (L x W x H)</b> Dimensi 体积	261x69x195mm (10-1/4"x2-3/4"x7-5/8")
<b>Net Weight</b> Berat Bersih 净重	1.7kg (3.7lbs)
<b>Power Supply Cord</b> Kabel Wayar 电源线	2.0m (6.6ft)

**M8100G** 16mm (5/8") 85

**Hammer Drill**

Gerudi Tukul  
冲击电钻



- 2-mode operation for hammering with rotation or rotation only  
Operasi 2 mod, penukulan dengan putaran atau hanya putaran  
2档模式变换, 旋转并锤击或仅旋转

Standard Equipment: Chuck Key, Side Grip, Depth Gauge



<b>Continuous Rating Input</b> Input Kuasa Berterusan 额定输入功率	710W
<b>Capacity</b> Kapasiti 能力	Concrete: 16mm (5/8") Steel: 13mm (1/2") Wood: 30mm (1-3/16")
<b>Impacts Per Minute (IPM)</b> Impak Per Minit 冲击数	0 - 48,000
<b>No Load Speed (RPM)</b> Kelajuan Tanpa Beban 回转数	0 - 3,200
<b>Dimensions (L x W x H)</b> Dimensi 体积	296x77x202mm (11-5/8"x3"x8")
<b>Net Weight</b> Berat Bersih 净重	2.1kg (4.6lbs.)
<b>Power Supply Cord</b> Kabel Wayar 电源线	2.0m (6.6ft.)

**M8700G** 22mm (7/8") 459

**Rotary Hammer**

Tukul Putar  
电锤



- 2-mode operation for hammering with rotation or rotation only  
Operasi 2 mod, penukulan dengan putaran atau hanya putaran  
2档模式变换, 旋转并锤击或仅旋转

Standard Equipment: Side Grip, Depth Gauge



<b>Continuous Rating Input</b> Input Kuasa Berterusan 额定输入功率	710W
<b>Impact Energy</b> Kekuatan Impak 单次最大锤击力	EPTA-Procedure 05/2009: 1.9J Our experimental conditions: N/A J
<b>Capacity</b> Kapasiti 能力	Concrete: 22mm (7/8") Core Bit: 54mm (2-1/8") Diamond Core Bit (Dry Type): 65mm (2-9/16") Steel: 13mm (1/2") Wood: 32mm (1-1/4")
<b>Impacts Per Minute (IPM)</b> Impak Per Minit 冲击数	0 - 4,350
<b>No Load Speed (RPM)</b> Kelajuan Tanpa Beban 回转数	0 - 1,100
<b>Dimensions (L x W x H)</b> Dimensi 体积	362x71x194mm (14-1/4"x2-13/16"x7-5/8")
<b>Net Weight</b> Berat Bersih 净重	2.5 - 2.9kg (5.6 - 6.4lbs)
<b>Power Supply Cord</b> Kabel Wayar 电源线	4.0m (13.1ft.)

**M8701X3G** 459

**Combination Hammer**

Tukul Kombinasi  
冲击电钻电锤



- 3-mode operating - rotation only, hammering with rotation, hammering only  
Operasi 3 mod: hanya putaran, penukulan dengan putaran, hanya penukulan  
3档模式变换: 仅旋转, 旋转并锤击, 仅锤击

Standard Equipment: Side Grip, Depth Gauge, Drill Chuck, SDS-Plus Chisel Assortment 3pcs Set (D-30134)



<b>Continuous Rating Input</b> Input Kuasa Berterusan 额定输入功率	800W
<b>Impact Energy</b> Kekuatan Impak 单次最大锤击力	EPTA-Procedure 05/2009: 2.3J Our experimental conditions: N/A J
<b>Capacity</b> Kapasiti 能力	Concrete : 26mm (1") Core Bit: 68mm (2-11/16") Diamond Core Bit (Dry Type): 80mm (3-1/8") Steel : 13mm (1/2") Wood : 32mm (1-1/4")
<b>Impacts per minute (ipm)</b> Impak Per Minit 冲击数	0-4,500
<b>No Load Speed (RPM)</b> Kelajuan Tanpa Beban 回转数	0-1,200
<b>Dimensions (L x W x H)</b> Dimensi 体积	362x71x194mm (14-1/4"x2-13/16"x7-5/8")
<b>Net Weight</b> Berat Bersih 净重	2.7kg (6.0lbs)
<b>Power Supply Cord</b> Kabel Wayar 电源线	4.0m (13.1ft)

Cordless  
Terdapat Kord Listrik

LED Flashlight  
Lampu Suluh LED  
LED照灯

Vacuum Cleaner  
Pembersih Vakuum  
吸尘器

Drilling / Fastening  
Gerudi / Pengikat  
钻孔 / 紧固

Impact Drilling / Demolition  
Gerudi / Pemecah  
石工钻孔 / 凿裂加工

Cutting  
Pemotong  
切割

Grinding / Sanding  
Pengisar / Pelsin  
研磨 / 打磨

Sawing  
Gergaji  
锯切

Planing / Routing  
Pengaliran / Tumpang  
刨削 / 雕刻

Others  
Lain-lain  
其他

Outdoor Power Equipment  
Alatan Kerja Luar  
园机/户外





Cordless  
Tanpa Kabel 无绳式

LED Flashlight  
Lampu Suhu LED  
LED照明灯

Vacuum Cleaner  
Pembersih Vakum  
吸尘器

Drilling | Fastening  
Gerudi | Pengikat  
钻孔 | 紧固

Impact Drilling | Demolition  
Gerudi | Pemecah  
石工钻孔 | 砸裂加工

Cutting  
Pemotong  
切割

Grinding | Sanding  
Pengisar | Pemoles  
研磨 | 砂磨

Sawing  
Gergaji  
锯切

Planing | Routing  
Pergelam | Tanggaman  
刨削 | 雕刻

Others  
Lain-lain  
其他

Outdoor Power Equipment  
Alat-alat Kerja Luar  
园林-户外

**M8600G** 17mm (11/16") Hex Shank

105

**Demolition Hammer**

Tukul Elektrik  
电动锤

- Satisfactory chipping performance  
Prestasi penyerpahan yang memuaskan  
卓越碎击性能



Standard Equipment: Bull Point, Side Grip



<b>Continuous Rating Input</b> Input Kuasa Berterusan 额定输入功率	900W
<b>Impact Energy</b> Kekuatan Impak 单次最大锤击力	7.2J
<b>Impacts Per Minute (IPM)</b> Impak Per Minit 冲击数	2,900
<b>Dimensions (L x W x H)</b> Dimensi 体积	406x99x232mm (16"x3-7/8"x9-1/8")
<b>Net Weight</b> Berat Bersih 净重	5.4kg (12lbs)
<b>Power Supply Cord</b> Kabel Wayar 电源线	2.5m (8.2ft)

**M9509G | M9513G** 100mm (4")

**Angle Grinder**  
Pengisar Sudut 角向磨光机

- Powerful 850W motor for the most demanding applications  
Motor berkuasa 850W untuk aplikasi yang paling mencabar  
强力850W马达适合严峻使用

Standard Equipment: M9509G: Side Grip, Lock Nut Wrench  
M9513G: Side Grip



<b>Continuous Rating Input</b> Input Kuasa Berterusan 额定输入功率	850W
<b>Wheel Diameter</b> Diameter Roda 轮片直径	100mm (4")
<b>No Load Speed (RPM)</b> Kelajuan Tanpa Beban 回转速	11,000
<b>Dimensions (L x W x H)</b> Dimensi 体积	276x118x101mm <b>M9509G</b> 273x118x101mm <b>M9513G</b> (10-3/4"x4-5/8"x4")
<b>Net Weight</b> Berat Bersih 净重	1.8kg (3.9lbs)
<b>Power Supply Cord</b> Kabel Wayar 电源线	2.0m (6.6ft)

**M9509G**

**Toggle Switch**  
Suis Togol 后置式开关

**M9513G**

**Slide Switch**  
Suis Gelangsar 滑动开关

**M9506G | M9512G** 100mm (4")

**Angle Grinder**  
Pengisar Sudut 角向磨光机

- Powerful 720W motor for the most demanding applications  
Motor berkuasa 720W untuk aplikasi yang paling mencabar  
强力720W马达适合严峻使用

Standard Equipment: Side Grip, Lock Nut Wrench



<b>Continuous Rating Input</b> Input Kuasa Berterusan 额定输入功率	720W
<b>Wheel Diameter</b> Diameter Roda 轮片直径	100mm (4")
<b>No Load Speed (RPM)</b> Kelajuan Tanpa Beban 回转速	11,000
<b>Dimensions (L x W x H)</b> Dimensi 体积	261x118x101mm <b>M9506G</b> 258x118x101mm <b>M9512G</b> (10-1/8"x4-5/8"x4")
<b>Net Weight</b> Berat Bersih 净重	1.6kg (3.6lbs)
<b>Power Supply Cord</b> Kabel Wayar 电源线	2.0m (6.6ft)

**M9506G**

**Toggle Switch**  
Suis Togol 后置式开关

**M9512G**

**Slide Switch**  
Suis Gelangsar 滑动开关

**M0900G | M0910G** 100mm (4")

**Angle Grinder**  
Pengisar Sudut 角向磨光机

- High performance and durability  
Prestasi dan ketahanan tinggi  
高性能与持久耐用

Standard Equipment: Lock Nut Wrench



<b>Continuous Rating Input</b> Input Kuasa Berterusan 额定输入功率	540W
<b>Wheel Diameter</b> Diameter Roda 轮片直径	100mm (4")
<b>No Load Speed (RPM)</b> Kelajuan Tanpa Beban 回转速	12,000
<b>Dimensions (L x W x H)</b> Dimensi 体积	251x118x97mm <b>M0900G</b> (9-7/8"x4-5/8"x3-13/16") 251x118x93mm <b>M0910G</b> (9-7/8"x4-5/8"x3-5/8")
<b>Net Weight</b> Berat Bersih 净重	1.6kg (3.5lbs)
<b>Power Supply Cord</b> Kabel Wayar 电源线	2.0m (6.6ft)

**M0900G**

**Toggle Switch**  
Suis Togol 后置式开关

**M0910G**

**Top Slide Switch**  
Suis Gelangsar Atas 顶部滑动开关  
Convenient for left & right handed  
Mudah diguna dengan tangan  
kiri atau kanan 方便左右手



**M9504G** 100mm (4") 411

**Angle Grinder**  
Pengisar Sudut  
角向磨光机

**Toggle Switch**  
Suis Togol 后置式开关

- **High performance and durability**  
Prestasi dan ketahanan tinggi  
高性能与持久耐用

**Standard Equipment:**  
Lock Nut Wrench

**WHEEL DIAMETER**  
Diameter Roda | 轮片直径  
**4"**  
(100mm)

<b>Continuous Rating Input</b> Input Kuasa Berterusan 额定输入功率	570W
<b>Wheel Diameter</b> Diameter Roda 轮片直径	100mm (4")
<b>No Load Speed (RPM)</b> Kelajuan Tanpa Beban 回转数	12,000
<b>Dimensions (L x W x H)</b> Dimensi 体积	256x118x92mm (10-1/8"x4-5/8"x3-5/8")
<b>Net Weight</b> Berat Bersih 净重	1.8kg (4.0lbs.)
<b>Power Supply Cord</b> Kabel Wayar 电源线	2.0m (6.6ft)

**M9511G** 125mm (5") 325

**Angle Grinder**  
Pengisar Sudut  
角向磨光机

**Slide Switch**  
Suis Gelasar 滑动开关

- **Slimmer barrel grip with easy gripping and handling**  
Memberikan prestasi kawalan unggul dan keselesaan  
提供更优异的控制性能和舒适度

**Standard Equipment:**  
Side Grip, Lock Nut Wrench

**WHEEL DIAMETER**  
Diameter Roda | 轮片直径  
**5"**  
(125mm)

<b>Continuous Rating Input</b> Input Kuasa Berterusan 额定输入功率	850W
<b>Wheel Diameter</b> Diameter Roda 轮片直径	125mm (5")
<b>No Load Speed (RPM)</b> Kelajuan Tanpa Beban 回转数	11,000
<b>Dimensions (L x W x H)</b> Dimensi 体积	276x140x111mm (10-7/8"x5-1/2"x4-3/8")
<b>Net Weight</b> Berat Bersih 净重	2.0kg (4.5lbs)
<b>Power Supply Cord</b> Kabel Wayar 电源线	2.0m (6.6ft)

**M9508G** 125mm (5") 459

**Angle Grinder**  
Pengisar Sudut  
角向磨光机

**Slide Switch**  
Suis Gelasar 滑动开关

- **Compact and lightweight for high production work**  
Kompak dan ringan untuk kerja pengeluaran yang tinggi  
紧凑轻巧型，更有效率地工作

**Standard Equipment:**  
Side Grip, Lock Nut Wrench, Wheel Cover

**WHEEL DIAMETER**  
Diameter Roda | 轮片直径  
**5"**  
(125mm)

<b>Continuous Rating Input</b> Input Kuasa Berterusan 额定输入功率	720W
<b>Wheel Diameter</b> Diameter Roda 轮片直径	125mm (5")
<b>No Load Speed (RPM)</b> Kelajuan Tanpa Beban 回转数	11,000
<b>Dimensions (L x W x H)</b> Dimensi 体积	261x140x111mm (10-1/4"x5-1/2"x4-3/8")
<b>Net Weight</b> Berat Bersih 净重	1.9kg (4.1lbs)
<b>Power Supply Cord</b> Kabel Wayar 电源线	2.0m (6.6ft)

**M9503G** 125mm (5") 411

**Angle Grinder**  
Pengisar Sudut  
角向磨光机

**Top Slide Switch**  
Suis Gelasar Atas 顶部滑动开关  
**Convenient for left & right handed**  
Mudah diguna dengan tangan kiri atau kanan 方便左右手

- **Ideal for welders, fabricators, masons, maintenance/ repair and more**  
Ideal untuk pengimpal, fabrikasi, tukang batu, penyelenggaraan atau pembaikan dan banyak lagi  
适用于焊工，制造商，泥瓦匠，维修与修理等

**Standard Equipment:**  
Side Grip, Lock Nut Wrench

**WHEEL DIAMETER**  
Diameter Roda | 轮片直径  
**5"**  
(125mm)

<b>Continuous Rating Input</b> Input Kuasa Berterusan 额定输入功率	570W
<b>Wheel Diameter</b> Diameter Roda 轮片直径	125mm (5")
<b>No Load Speed (RPM)</b> Kelajuan Tanpa Beban 回转数	11,000
<b>Dimensions (L x W x H)</b> Dimensi 体积	270x140x110mm (10-5/8"x5-1/2"x4-5/16")
<b>Net Weight</b> Berat Bersih 净重	2.0kg (4.4lbs)
<b>Power Supply Cord</b> Kabel Wayar 电源线	2.0m (6.6ft)

**M9002G** 125mm (5") 303

**Angle Grinder**  
Pengisar Sudut  
角向磨光机

**Trigger Switch**  
Suis Pemicu 扳机开关

- **High performance and durability**  
Prestasi dan ketahanan tinggi  
高性能与持久耐用

**Standard Equipment:**  
Side Grip, Lock Nut Wrench

**WHEEL DIAMETER**  
Diameter Roda | 轮片直径  
**5"**  
(125mm)

<b>Continuous Rating Input</b> Input Kuasa Berterusan 额定输入功率	1,050W
<b>Wheel Diameter</b> Diameter Roda 轮片直径	125mm (5")
<b>No Load Speed (RPM)</b> Kelajuan Tanpa Beban 回转数	11,000
<b>Dimensions (L x W x H)</b> Dimensi 体积	361x140x124mm (14-1/4"x5-1/2"x4-7/8")
<b>Net Weight</b> Berat Bersih 净重	2.8kg (6.1lbs.)
<b>Power Supply Cord</b> Kabel Wayar 电源线	2.0m (6.6ft)

**Cordless**  
Tempa Kord 无绳式

**LED Flashlight**  
Lampu Suluh LED  
LED照明灯

**Vacuum Cleaner**  
Pembersih Vakuum  
吸尘器

**Drilling | Fastening**  
Cendul | Pengikat  
钻孔 | 紧固

**Impact Drilling | Demolition**  
Gerudi | Pemecah  
石工钻孔 | 衝撃加工

**Cutting**  
Pemotong  
切割

**Grinding | Sanding**  
Pengisar | Pelsih  
研磨 | 打磨

**Sawing**  
Gergaji  
锯切

**Planing | Routing**  
Pengaliran | Tanggaman  
刨削 | 雕刻

**Others**  
Lain-lain  
其他

**Outdoor Power Equipment**  
Alatan Kerja Luar  
园机/户外

**M9000G** 180mm (7")

204

**Angle Grinder**Pengisar Sudut  
角向磨光机

- **Powerful 2,000W motor for the most demanding applications**  
Motor berkuasa 2,000W untuk aplikasi yang paling mencabar  
强力2,000W马达适合严峻使用

**Trigger Switch**  
Suis Pemicu 扳机开关

**Standard Equipment:**  
Side Grip, Lock Nut Wrench



<b>Continuous Rating Input</b> Input Kuasa Berterusan 额定输入功率	2,000W
<b>Wheel Diameter</b> Diameter Roda 轮片直径	180mm (7")
<b>No Load Speed (RPM)</b> Kelajuan Tanpa Beban 回转数	8,500
<b>Dimensions (L x W x H)</b> Dimensi 体积	466x200x138mm (18-3/8"x7-7/8"x5-7/16")
<b>Net Weight</b> Berat Bersih 净重	5.4kg (12.0lbs.)
<b>Power Supply Cord</b> Kabel Wayar 电源线	2.0m (6.6ft.)

**M9001G** 230mm (9")

204

**Angle Grinder**Pengisar Sudut  
角向磨光机

- **Powerful 2,000W motor for the most demanding applications**  
Motor berkuasa 2,000W untuk aplikasi yang paling mencabar  
强力2,000W马达适合严峻使用

**Trigger Switch**  
Suis Pemicu 扳机开关

**Standard Equipment:**  
Side Grip, Lock Nut Wrench



<b>Continuous Rating Input</b> Input Kuasa Berterusan 额定输入功率	2,000W
<b>Wheel Diameter</b> Diameter Roda 轮片直径	230mm (9")
<b>No Load Speed (RPM)</b> Kelajuan Tanpa Beban 回转数	6,600
<b>Dimensions (L x W x H)</b> Dimensi 体积	466x250x138mm (18-3/8"x9-7/8"x5-7/16")
<b>Net Weight</b> Berat Bersih 净重	5.7kg (12.6lbs.)
<b>Power Supply Cord</b> Kabel Wayar 电源线	2.0m (6.6ft.)

**M9400G** 100mm (4")

153

**Belt Sander**Pengampelas  
带式砂光机

- **Powerful 940W motor for faster material removal**  
Motor berkuasa 940W untuk pengisaran yang lebih cepat  
功率强大的940W马达提供更快的研磨

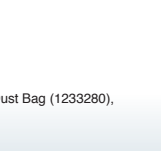

**Standard Equipment:** Abrasive Belt, Dust Bag (1233280),  
Carbon Plate, Step



<b>Continuous Rating Input</b> Input Kuasa Berterusan 额定输入功率	940W
<b>Belt Size</b> Saiz Tali Pinggang 皮带尺寸	100 x 610mm (4" x 24")
<b>Belt Speed</b> Kelajuan Tali Pinggang 皮带速度	380m/min (1,250ft/min)
<b>Dimensions (L x W x H)</b> Dimensi 体积	354x175x169mm (14"x6-7/8"x6-5/8")
<b>Net Weight</b> Berat Bersih 净重	6.2kg (13.7lbs.)
<b>Power Supply Cord</b> Kabel Wayar 电源线	2.0m (6.6ft.)

**M9204G** 125mm (5")

419

**Random Orbit Sander**Pengampelas  
砂光机

- **Available with dust bag and also connectable to vacuum cleaners without adapter**  
Dengan beg debu dan juga boleh disambungkan ke pembersih vakum tanpa penyesuai  
配有防尘袋且可连接到没有连接器的吸尘器



**Standard Equipment:** Dust Bag, Abrasive Paper



<b>Continuous Rating Input</b> Input Kuasa Berterusan 额定输入功率	240W
<b>Pad Size</b> Saiz Pad 垫大小	123mm (4-7/8")
<b>Abrasive Paper Size</b> Saiz Kertas Pasir 砂纸尺寸	125mm (5")
<b>Orbits Per Minute (OPM)</b> Bilangan Putaran 轨道转数	12,000
<b>Strokes Per Minute (SPM)</b> Kelajuan Strok 冲程速度	24,000
<b>Orbit Diameter</b> Jejaki Diameter 轨道直径	2.8mm (1/8")
<b>Dimensions (L x W x H)</b> Dimensi 体积	153x123x144mm (6"x4-7/8"x5-5/8")
<b>Net Weight</b> Berat Bersih 净重	1.2kg (2.6lbs)
<b>Power Supply Cord</b> Kabel Wayar 电源线	2.0m (6.6ft)

**M9202G**

419

**Random Orbit Sander**Pengampelas  
砂光机

- **Rocker on/off switch for efficient operation**  
Suis gelanggar untuk operasi yang cekap  
滑动式按钮开关有效操作



**Standard Equipment:** Abrasive Paper



<b>Continuous Rating Input</b> Input Kuasa Berterusan 额定输入功率	240W
<b>Pad Size</b> Saiz Pad 垫大小	123mm (4-7/8")
<b>Abrasive Disc Size</b> Saiz Cakera 磨盘尺寸	125mm (5")
<b>Orbits Per Minute (OPM)</b> Bilangan Putaran 轨道转数	12,000
<b>Strokes Per Minute (SPM)</b> Kelajuan Strok 冲程速度	24,000
<b>Orbit Diameter</b> Jejaki Diameter 轨道直径	2.8mm (1/8")
<b>Dimensions (L x W x H)</b> Dimensi 体积	127x123x142mm (5"x4-7/8"x5-5/8")
<b>Net Weight</b> Berat Bersih 净重	1.1kg (2.4lbs)
<b>Power Supply Cord</b> Kabel Wayar 电源线	2.0m (6.6ft)

**M9200G**

419

**Finishing Sander**  
Pengampelas  
砂光机

- 14,000OPM for fast and smooth finish sanding  
14,000OPM untuk pelicin dengan cepat  
14000OPM用于快速研磨



Standard Equipment: Abrasive paper



<b>Continuous Rating Input</b> Input Kuasa Berterusan 额定输入功率	180W
<b>Pad Size</b> Saiz Pad 垫大小	112 x 102mm (4-3/8" x 4")
<b>Abrasive Paper Size</b> Saiz Kertas Pasir 砂纸尺寸	114 x 140mm (4-1/2" x 5-1/2")
<b>Orbits Per Minute (OPM)</b> Bilangan Putaran 轨道转速	14,000
<b>Dimensions (L x W x H)</b> Dimensi 体积	110x112x133mm (4-5/16"x4-3/8"x5-1/4")
<b>Net Weight</b> Berat Bersih 净重	0.9kg (2lbs)
<b>Power Supply Cord</b> Kabel Wayar 电源线	2.0m (6.6ft)

**M9201G**

64

**Finishing Sander**  
Pengampelas  
砂光机

- Compact and lightweight body for better handling  
Padat dan ringan  
小巧轻便的机身易于操纵



Standard Equipment: Abrasive Paper



<b>Continuous Rating input</b> Input Kuasa Berterusan 额定输入功率	180W
<b>Pad Size</b> Saiz Pad 垫大小	93 x 185mm (3-5/8" x 7-1/4")
<b>Abrasive Paper Size</b> Saiz Kertas Pasir 砂纸尺寸	93 x 228mm (3-5/8" x 9")
<b>Orbits Per Minute (OPM)</b> Bilangan Putaran 轨道转速	12,000
<b>Dimensions (L x W x H)</b> Dimensi 体积	214x92x147mm (8-3/8"x3-5/8"x5-3/4")
<b>Net Weight</b> Berat Bersih 净重	1.4kg (3.1lbs)
<b>Power Supply Cord</b> Kabel Wayar 电源线	2.0m (6.6ft)

**M5801G 185mm (7-1/4")**

303

**Circular Saw**  
Gergaji Piring  
圆锯

- High performance and durability  
Prestasi dan ketahanan tinggi  
高性能兼耐用



Standard Equipment: TCT Saw Blade, Guide Rule, Hex Wrench



<b>Continuous Rating Input</b> Input Kuasa Berterusan 额定输入功率	1,050W
<b>Blade Diameter</b> Diameter Roda 轮片直径	185mm (7-1/4")
<b>Max Cutting Capacity</b> Kapasiti Pemotongan Maksimum 最大切割能力	90°: 66mm (2-5/8") 45°: 44mm (1-3/4")
<b>No Load Speed (RPM)</b> Kelajuan Tanpa Beban 回转速数	4,900
<b>Dimensions (L x W x H)</b> Dimensi 体积	284x231x243mm (11-1/8"x9-1/8"x9-9/16")
<b>Net Weight</b> Berat Bersih 净重	3.5kg (7.7lbs)
<b>Power Supply Cord</b> Kabel Wayar 电源线	2.0m (6.6ft)

**M2300G 255mm (10")**

500

**Compound Miter Saw**  
Gergaji Kompaun Miter  
斜断锯

- Powerful 1,500W motor  
Motor berkuasa 1,500W  
强力1.500W马达



Standard Equipment: Wrench, Dust Bag, Triangular Rule, Vice Assembly, Set Plate, Vortice Vise



<b>Continuous Rating Input</b> Input Kuasa Berterusan 额定输入功率	1,500W
<b>Blade Diameter</b> Diameter Bilah 锯片直径	255mm (10")
<b>Miter Angle</b> Sudut Miter 斜接角	45°L / 45°R
<b>Bevel Angle</b> Sudut Bevel 斜角	45°L
<b>Max Cutting Capacity</b> Kapasiti Pemotongan Maksimum 最大切割能力	90° Miter: 75 x 130mm (2-15/16" x 5-1/8") 45° Miter, L/R: 75 x 90mm (2-15/16" x 3-9/16")
<b>No Load Speed (RPM)</b> Kelajuan Tanpa Beban 回转速数	4,200
<b>Dimensions (L x W x H)</b> Dimensi 体积	610x485x515mm (24"x19-1/8"x20-1/4")
<b>Net Weight</b> Berat Bersih 净重	14.7kg (32.5lbs)
<b>Power Supply Cord</b> Kabel Wayar 电源线	2.5m (8.2ft)

**M4302G**

411

**Jig Saw**  
Gergaji Jig  
线锯机

- Heavy duty aluminum gear housing for increased durability  
Gear aluminium tugas berat untuk meningkatkan ketahanan  
重型铝制齿轮组件结构提高耐用性



Standard Equipment: 2x Jig Saw Blade (B-13 & No. 51), Hex Wrench



<b>Continuous Rating Input</b> Input Kuasa Berterusan 额定输入功率	450W
<b>Max Cutting Capacity at 90°</b> Kapasiti Pemotongan Maksimum 最大切割能力	Wood: 55mm (2-3/16") Steel: 6mm (1/4")
<b>Length of Stroke</b> Panjang Strok 冲程长度	26mm (1")
<b>Strokes Per Minute (SPM)</b> Kelajuan Strok 冲程速度	0 - 3,100
<b>Dimensions (L x W x H)</b> Dimensi 体积	219x85x191mm (8-5/8"x3-3/8"x7-1/2")
<b>Net Weight</b> Berat Bersih 净重	2.5kg (5.5lbs.)
<b>Power Supply Cord</b> Kabel Wayar 电源线	2.0m (6.6ft.)

Cordless  
Tempat Kord 无绳式

LED Flashlight  
Lampu Suluh LED  
LED照明灯

Vacuum Cleaner  
Pembersih Vakuum  
吸尘器

Drilling | Fastening  
Ceculi | Pengikat  
钻孔 | 紧固

Impact Drilling | Demolition  
Gerudi | Pemecah  
石工钻孔 | 拆毁加工

Cutting  
Pemotong  
切割

Grinding | Sanding  
Pengisar | Pelsin  
研磨 | 打磨

Sawing  
Gergaji  
锯切

Planing | Routing  
Pengaliran | Tanggaman  
刨削 | 雕花

Others  
Lain-lain  
其他

Outdoor Power Equipment  
Alatan Kerja Luar  
园机/户外



Cordless  
Tanpa Kord Listrik

LED Flashlight  
Lampu Suluh LED  
LED照明灯

Vacuum Cleaner  
Pembersih Vakum  
吸尘器

Drilling | Fastening  
Gerudi | Pengikat  
钻孔 | 紧固

Impact Drilling | Demolition  
Gerudi | Pemecah  
石工钻孔 | 砸裂加工

Cutting  
Pemotong  
切割

Grinding | Sanding  
Pengisar | Pelsih  
研磨 | 砂磨

Sawing  
Gergaji  
锯切

Planing | Routing  
Pengaliran | Tunggam  
刨削 | 雕刻

Others  
Lain-lain  
其他

Outdoor Power Equipment  
Alat-alat Kerja Luar  
园林·户外

M4301G

64

Jig Saw  
Gergaji Jig  
线锯机

- **Powerful 450W motor**  
Motor berkuasa 450W  
强力450W马达



Standard Equipment: Jig Saw Blade (B-10), Hex Wrench



<b>Continuous Rating Input</b> Input Kuasa Berterusan 额定输入功率	450W
<b>Max Cutting Capacity at 90°</b> Kapasiti Pemotongan Maksimum 最大切割能力	Wood: 65mm (2-9/16") Steel: 6mm (1/4")
<b>Length of Stroke</b> Panjang Strok 冲程长度	18mm (11/16")
<b>Strokes Per Minute (SPM)</b> Kelajuan Strok 冲程速度	0 - 3,100
<b>Dimensions (L x W x H)</b> Dimensi 体积	214x75x202mm (8-3/8"x2-15/16"x8")
<b>Net Weight</b> Berat Bersih 净重	1.9kg (4.1lbs)
<b>Power Supply Cord</b> Kabel Wayar 电源线	2.0m (6.6ft)

M4501G

303

Recipro Saw  
Gergaji Resipro  
往复锯

- **Powerful 1,010W motor for improved performance**  
Motor berkuasa 1,010W untuk prestasi lebih baik  
强劲的1,010W马达提高性能



<b>Continuous Rating Input</b> Input Kuasa Berterusan 额定输入功率	1,010W
<b>Length of Stroke</b> Panjang Strok 冲程长度	28mm (1-1/8")
<b>Strokes Per Minute (SPM)</b> Kelajuan Strok 冲程速度	0 - 2,800
<b>Capacity</b> Kapasiti 能力	Pipe : 130mm (5-1/8") Wood: 255mm (10")
<b>Dimensions (L x W x H)</b> Dimensi 体积	457x98x170mm (18"x3-7/8"x6-11/16")
<b>Net Weight</b> Berat Bersih 净重	3.2kg (7lbs)
<b>Power Supply Cord</b> Kabel Wayar 电源线	2.0m (6.6ft)

M0400G 110mm (4-3/8")

303

Cutter  
Pemotong  
切割机

- **Powerful 1,200W motor**  
Motor berkuasa 1,200W  
强力1,200W马达



Standard Equipment: Wrench, Hex Wrench  
(Tool does not come with Diamond Wheel)



<b>Continuous Rating Input</b> Input Kuasa Berterusan 额定输入功率	1,200W
<b>Blade Diameter</b> Diameter Bilah 锯片直径	110mm (4-3/8")
<b>Max Cutting Capacity</b> Kapasiti Pemotongan Maksimum 最大切割能力	90°: 32mm (1-1/4")
<b>No Load Speed (RPM)</b> Kelajuan Tanpa Beban 回转速数	13,800
<b>Dimensions (L x W x H)</b> Dimensi 体积	224x195x164mm (8-7/8"x7-5/8"x6-1/2")
<b>Net Weight</b> Berat Bersih 净重	2.5kg (5.6lbs.)
<b>Power Supply Cord</b> Kabel Wayar 电源线	2.0m (6.6ft.)

M4100G 110mm (4-3/8")

303

Cutter  
Pemotong  
切割机

- **Compact and lightweight for reduced operator fatigue**  
Kompak dan ringan untuk mengurangkan keletihan pengguna  
小巧轻便，减少疲劳



Standard Equipment: Wrench, Hex Wrench, Water Supply Set  
(Tool does not come with Diamond Wheel)



<b>Continuous Rating Input</b> Input Kuasa Berterusan 额定输入功率	1,200W
<b>Blade Diameter</b> Diameter Bilah 锯片直径	110mm (4-3/8")
<b>Max Cutting Capacity</b> Kapasiti Pemotongan Maksimum 最大切割能力	90°: 32mm (1-1/4")
<b>No Load Speed (RPM)</b> Kelajuan Tanpa Beban 回转速数	13,000
<b>Dimensions (L x W x H)</b> Dimensi 体积	227x209x166mm (8-15/16"x8-1/4"x6-1/2")
<b>Net Weight</b> Berat Bersih 净重	2.9kg (6.4lbs)
<b>Power Supply Cord</b> Kabel Wayar 电源线	2.0m (6.6ft.)

M2400G 355mm (14")

203

Portable Cut-off  
Mesin Pemotong  
型材切割机

- **Powerful 2,000W motor**  
Motor berkuasa 2,000W  
强力2,000W马达



Standard Equipment: Abrasive Cut-Off Wheel, Socket Wrench



<b>Continuous Rating Input</b> Input Kuasa Berterusan 额定输入功率	2,000W
<b>Wheel Diameter</b> Diameter Roda 轮片直径	355mm (14")
<b>No Load Speed (RPM)</b> Kelajuan Tanpa Beban 回转速数	3,800
<b>Dimensions (L x W x H)</b> Dimensi 体积	500x280x620mm (19-3/4"x11"x24-3/8")
<b>Net Weight</b> Berat Bersih 净重	15.7kg (34.6lbs)
<b>Power Supply Cord</b> Kabel Wayar 电源线	2.5m (8.2ft)



**M2401G** 355mm (14")

203

**Portable Cut-off**  
Mesin Pemotong  
型材切割机

- **Large cutting capacity; Cuts up to 127mm (5") round and 102mm (4") x 194mm (7-5/8") rectangular**  
Kapasiti pemotongan tinggi  
切割能力高



**Standard Equipment:** Abrasive Cut-Off Wheel, Hex Wrench



<b>Continuous Rating Input</b> Input Kuasa Berterusan 额定输入功率	2,000W
<b>Wheel Diameter</b> Diameter Roda 轮片直径	355mm (14")
<b>No Load Speed (RPM)</b> Kelajuan Tanpa Beban 回转数	3,800
<b>Dimensions (L x W x H)</b> Dimensi 体积	500x280x620mm (19-3/4"x11"x24-3/8")
<b>Net Weight</b> Berat Bersih 净重	13.7kg (30.2lbs.)
<b>Power Supply Cord</b> Kabel Wayar 电源线	2.5m (8.2ft.)

**M1100G** 82mm (3-1/4")

303

**Planer**  
Planer  
电刨

- **Easy blade setting system for fast blade installation**  
Sistem pemasangan bilah mudah  
刀片易安装系统



**Standard Equipment:** Planer Blade, Sharpening Holder Assembly (for resharpenable blade), Blade Gauge, Socket Wrench, Guide Rule



<b>Continuous Rating Input</b> Input Kuasa Berterusan 额定输入功率	750W
<b>Planing Width</b> Lebar Pelan 刨削宽度	82mm (3-1/4")
<b>Planing Depth</b> Kedalaman Pelan 刨削深度	3mm (1/8")
<b>No Load Speed (RPM)</b> Kelajuan Tanpa Beban 回转数	18,000
<b>Dimensions (L x W x H)</b> Dimensi 体积	390x175x140mm (15-3/8"x6-7/8"x5-1/2")
<b>Net Weight</b> Berat Bersih 净重	4.6kg (10.2lbs.)
<b>Power Supply Cord</b> Kabel Wayar 电源线	2.0m (6.6ft.)

**M1901G | M1902G** 82mm (3-1/4")

411

**Planer**  
Planer  
电刨

- **High performance and durability**  
Prestasi dan ketahanan tinggi  
高性能兼耐用



**Standard Equipment:**  
**M1901G:** Planer Blade, Sharpening Holder Assembly (for resharpenable blade), Blade Gauge, Socket Wrench, Guide Rule  
**M1902G:** Planer Blade, Sharpening Holder Assembly (for resharpenable blade), Blade Gauge, Guide Rule



<b>Continuous Rating Input</b> Input Kuasa Berterusan 额定输入功率	580W
<b>Planing Width</b> Lebar Pelan 刨削宽度	82mm (3-1/4")
<b>Planing Depth</b> Kedalaman Pelan 刨削深度	2mm (1/16") <b>M1901G</b> 1mm (1/32") <b>M1902G</b>
<b>No Load Speed (RPM)</b> Kelajuan Tanpa Beban 回转数	16,000
<b>Dimensions (L x W x H)</b> Dimensi 体积	285x157x160mm (11-1/4"x6-3/16"x6-5/16")
<b>Net Weight</b> Berat Bersih 净重	2.8 - 2.9kg (6.1 - 6.4lbs)
<b>Power Supply Cord</b> Kabel Wayar 电源线	2.0m (6.6ft)

**M3600G** 12mm (1/2")

203

**Router**  
Pemangkas  
雕刻机

- **Conveniently located plunge lock lever for efficient operation**  
Pelarasan tui yang mudah untuk operasi yang cekap  
便利的插入式锁定杆可实现高效操作



**Standard Equipment:** Straight Guide, Templet Guide, Guide Holder, Collet Sleeve, Straight Bit, Wrench



<b>Continuous Rating Input</b> Input Kuasa Berterusan 额定输入功率	1,650W
<b>Collet Capacity</b> Kapasiti Collet 夹头直径	12mm (1/2")
<b>Plunge Capacity</b> Kapasiti Plunge 能力	0 - 60mm (0 - 2-3/8")
<b>No Load Speed (RPM)</b> Kelajuan Tanpa Beban 回转数	22,000
<b>Dimensions (L x W x H)</b> Dimensi 体积	284x148x300mm (11-1/8"x5-7/8"x11-3/4")
<b>Net Weight</b> Berat Bersih 净重	5.5kg (12.2lbs.)
<b>Power Supply Cord</b> Kabel Wayar 电源线	2.0m (6.6ft.)

**M3601G** 6mm (1/4"), 8mm (3/8")

106

**Router**  
Pemangkas  
雕刻机

- **Powerful 900W motor**  
Motor berkuasa 900W  
强力900W马达



**Standard Equipment:** Straight Guide, Straight Bit (733238-9), Wrench



<b>Continuous Rating Input</b> Input Kuasa Berterusan 额定输入功率	900W
<b>Collet Capacity</b> Kapasiti Collet 夹头直径	6 mm (1/4")   8 mm (3/8")
<b>Plunge Capacity</b> Kapasiti Plunge 能力	0 - 35mm (0 - 1-3/8")
<b>No Load Speed (RPM)</b> Kelajuan Tanpa Beban 回转数	27,000
<b>Dimensions (L x W x H)</b> Dimensi 体积	256x110x218mm (10-1/8"x4-5/16"x8-5/8")
<b>Net Weight</b> Berat Bersih 净重	2.7kg (6.0lbs)
<b>Power Supply Cord</b> Kabel Wayar 电源线	2.0m (6.6ft)

**Cordless**  
Tanpa Kord 无绳式

**LED Flashlight**  
Lampu Suluh LED  
LED照明灯

**Vacuum Cleaner**  
Pembersih Vakuum  
吸尘器

**Drilling | Fastening**  
Cecut | Pengikat  
钻孔 | 紧固

**Impact Drilling | Demolition**  
Gerudi | Pemecah  
石工钻孔 | 衝撃加工

**Cutting**  
Pemotong  
切割

**Grinding | Sanding**  
Pengisar | Pelsin  
研磨 | 砂磨

**Sawing**  
Gergaji  
锯切

**Planing | Routing**  
Pegolan | Tanggan  
刨削 | 雕刻

**Others**  
Lain-lain  
其他

**Outdoor Power Equipment**  
Alatan Kerja Luar  
园机/户外

**M9800G**

459

**Multi Tool**

 Mesin Pemotong Berbilang Fungsi  
 多功能切割打磨机

**Lightweight Design**

 Reka bentuk yang padat dan ringan  
 紧凑轻巧的设计

**Standard Equipment:** Hex Wrench

**Oscillations Per Minute (OPM)**

Kelajuan Ayunan 摆动速度

15,000 - 22,000

**Oscillation Angle**

Sudut Ayunan 摆动角度

Left: 1.6° | Right: 1.6° | Total: 3.2°

**Dimensions (L x W x H)**

Dimensi 体积

283x68x98mm

(11-1/8"x2-11/16"x3-7/8")

**Net Weight**

Berat Bersih 净重

1.2 - 1.3kg (2.7 - 3.0 lbs.)

**Power Supply Cord**

Kabel Wayar 电源线

2.0m (6.6ft)

**M3700G 6mm (1/4")**

411

**Trimmer**

 Pemangkas  
 修边雕刻机

**Compact and lightweight body for better handling**

 Padat dan ringan  
 小巧轻便的机身易于操纵

**Standard Equipment:** Trimmer Guide, Straight Guide, Templet Guide, Straight Bit, Chip Deflector, Wrench

**Continuous Rating Input**

Input Kuasa Berterusan 额定输入功率

530W

**Collet Capacity**

Kapasiti Collet 夹头直径

6mm (1/4")

**Plunge Capacity**

Kapasiti Plunge 能力

0 - 42mm (0 - 1-5/8")

**No Load Speed (RPM)**

Kelajuan Tanpa Beban 回转数

35,000

**Dimensions (L x W x H)**

Dimensi 体积

82x90x199mm

(3-1/4"x3-1/2"x7-7/8")

**Net Weight**

Berat Bersih 净重

1.4kg (3.1lbs.)

**Power Supply Cord**

Kabel Wayar 电源线

2.0m (6.6ft)

**M3701G 6mm (1/4")**

411

**Trimmer**

 Pemangkas  
 修边雕刻机

**Aluminium housing for higher durability**

 Cangkang aluminium untuk ketahanan yang lebih tinggi  
 铝外壳更高的耐用性

**Standard Equipment:** Trimmer Guide, Straight Guide Assembly, Templet Guide, Straight Bit (733238A9), Chip Deflector, Wrench

**M4000G**

85

**Blower**

 Mesin Blower  
 吹风机

**Compact and lightweight increased operator comfort**

 Kompak dan ringan operasi yang selesa  
 小巧轻便操作舒适

**Standard Equipment:** Nozzle assembly, Sash Nozzle

**Continuous Rating Input**

Input Kuasa Berterusan 额定输入功率

530W

**Air Volume**

Isipadu Angin 风量

1.2-2.9m³/min

**No Load Speed (RPM)**

Kelajuan Tanpa Beban 回转数

8,500 - 16,000

**Dimensions (L x W x H)**

Dimensi 体积

427x161x212mm

(16-3/4"x6-3/8"x8-3/8")

**Net Weight**

Berat Bersih 净重

1.5kg (3.4lbs.)

**Power Supply Cord**

Kabel Wayar 电源线

2.0m (6.6ft)

**M4001G**

303

**Blower**

 Mesin Blower  
 吹风机

**Two tools in one; quickly converts to a vacuum for added versatility**

 Alat 2 dalam 1, vakum dan blower untuk fleksibiliti tambahan  
 一机2用, 集尘与吹风

**Standard Equipment:** Nozzle, Dust Bag

**Continuous Rating Input**

Input Kuasa Berterusan 额定输入功率

600W

**Max Air Volume**

Isipadu Angin Maksimum 最大风量

0 - 4.1m³/min

**Max Air Velocity**

Velositi Angin Maksimum 最大风速

0 - 91m/s

**Air Pressure**

Tekanan Udara 气压

0 - 5.7kPa

**No Load Speed (RPM)**

Kelajuan Tanpa Beban 回转数

0 - 16,000

**Dimensions (L x W x H)**

Dimensi 体积

480x185x178mm

(18-7/8"x7-1/4"x7")

**Net Weight**

Berat Bersih 净重

1.9 - 2.0kg (4.3 - 4.5lbs.)

**Power Supply Cord**

Kabel Wayar 电源线

2.0m (6.6ft)



# Safety Precautions

## Amaran keselamatan 安全须知

When using electric tools, basic safety precautions should always be followed to reduce the risk of fire, electric shock, and personal injury, including the following.

Apabila menggunakan alat kuasa, langkah keselamatan asas harus sentiasa diikuti untuk mengurangkan risiko kebakaran, kejutan elektrik dan kecederaan peribadi, termasuk yang berikut.

使用电动工具时，应始终遵循基本的安全预防措施，以降低火灾，触电和人身伤害的风险，包括以下内容。

### KEEP WORK AREA CLEAN.

PASTIKAN TEMPAT KERJA SENTIASA KEMAS 保持工作环境清洁

- Cluttered areas and benches invite injuries.

### CONSIDER WORK AREA ENVIRONMENT.

PERSEKITARAN KERJA SELAMAT 确保工作环境安全

- Don't use power tools in damp or wet locations. Keep work area well lit.
- Don't expose power tools to rain. Don't use power tool in presence of flammable liquids or gases.

### KEEP CHILDREN AWAY.

JAUHI DARIPADA CAPAIAN KANAK-KANAK 远离儿童

- All visitors should be kept away from work area.
- Don't let visitors touch the tool or extension cord.

### STORE IDLE TOOLS.

SIMPANKAN ALAT KERJA 工作完毕把工具收起

- When not in use, tools should be stored in a dry, high of locked up place, out of reach of children.

### DON'T FORCE THE TOOL.

MENGGUNA ALAT DENGAN CARA YANG BETUL 不要强制使用工具

- It will do the job better and safer at the rate for which it was intended.

### USE THE RIGHT TOOL.

MENGGUNAKAN ALAT YANG BETUL 使用正确的工具

- Don't force small tools or attachments to do the job of a heavy-duty tool.
- Don't use tools for purposes not intended.

### DRESS PROPERLY.

BERPAKAIAN DENGAN SESUAI 穿著正确

- Don't wear loose clothing or jewelry. They can be caught in moving parts.
- Rubber gloves and non-skid footwear are recommended when working outdoors. Wear protective hair covering to contain long hair.

### USE SAFETY GLASSES.

GUNAKAN GERMIN MATA KESELAMATAN 使用安全眼镜

- Also use face or dust mask if the cutting operation is dusty.

### DON'T ABUSE THE CORD.

JANGAN MENYALAHGUNAKAN KORD KUASA 滥用电源线

- Never carry the tool by the cord or yank it to disconnect it from the socket.
- Keep the cord away from heat, oil, and sharp edges.

### SECURE WORK.

BEKERJA DENGAN SELAMAT 安全的工作

- Use clamps or a vise to hold the work. It's safer than using your hand and it frees both hands to operate the tool.

### DON'T OVERREACH.

BERDIRI TEGAS APABILA MENGGUNAKAN ALAT 工作时身体要站稳

- Keep proper footing and balance at all times.

### MAINTAIN TOOLS WITH CARE.

PEMELIHARAAN ALAT 小心保养工具

- Keep cutting tools sharp and clean for better and safer performance. Follow instructions for lubrication and changing accessories. Inspect tool cord periodically and if damaged, have it repaired by an authorized service facility. Inspect extension cords periodically and replace, if damaged. Keep handles dry, clean and free from oil and grease.

### DISCONNECT TOOLS.

PASTIKAN SAMBUNGAN ELEKTRIK DIPUTUSKAN 截断电源

- When not in use, before servicing and when changing accessories such as blades, bits and cutters.

### REMOVE ADJUSTING KEYS AND WRENCHES.

PASTIKAN PEMASANGAN SIAP SEBELUM KERJA BERMULA 取下调整钥匙和扳手

- Form the habit of checking to see that keys and adjusting wrenches are removed from the tool before turning it on.

### AVOID UNINTENTIONAL STARTING.

ELEKKAN PENGHIDUPAN SECARA TIDAK SENGAJA 意外启动

- Don't carry a plugged-in tool with a finger on the switch.
- Ensure switch is OFF when plugging in.

### USE OUTDOOR EXTENSION CORDS.

GUNAKAN KORD SAMBUNGAN LUAR 使用户外延伸线

- When tool is used outdoors, use only extension cords intended for outdoor use.

### STAY ALERT.

SENTIASA BERJAGA-JAGA 保持警惕

- Watch what you are doing. Use common sense. Don't operate tool when you are tired.

### CHECK DAMAGED PARTS.

SEMAK BAHAGIAN ALAT YANG ROSAK 检查工具损坏的部件

- Before further use of the tool, a guard or other part that is damaged should be carefully checked to determine that it will operate properly and perform its intended function. Check for alignment of moving parts, free running of moving parts, breakage of parts, mounting and any other conditions that may affect its operation. A guard or other part that is damaged should be properly repaired or replaced by an authorized service center unless otherwise indicated in this instruction manual. Have defective switches replaced by an authorized service facility. Don't use the tool if the switch does not turn it on and off.

### GUARD AGAINST ELECTRIC SHOCK.

ELEKKAN KEJUTAN ELEKTRIK 防止电击

- Avoid body contact with earthed or grounded surfaces (e.g. pipes, radiators, ranges, refrigerators).

### REPLACEMENT PARTS.

MENGGANTIKAN BAHAGIAN ALAT 更换配件

- When servicing a tool, use only identical replacement parts.

### VOLTAGE WARNING.

AMARAN VOLTAN 电压警告

- Before connecting the tool to a power source (receptacle, outlet, etc.) Be sure the voltage supplied is the same as that specified on the nameplate of the tool. A power source with voltage greater than that specified for the tool can result in SERIOUS INJURY to the user V as well as damage to the tool. If in doubt, DO NOT PLUG IN THE TOOL. Using a power source with voltage less than the nameplate rating is harmful to the motor.

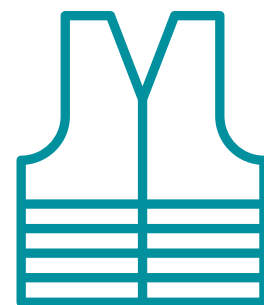

## Note Nota 注意

- Makita reserves the right to change specifications of parts and accessories without notice.
- Items of standard equipment and specifications may vary by country or area.
- Net weight and dimensions may differ by the type of battery.
- Standard export color for motor housing is Makita industrial green (blue).
- Please state required voltage when ordering. These offers are subject to availability in each country. Actual product color may differ slightly from color reproduced here.
- Weight data in this catalogue is the value measured by us according to EPTA Procedure 01/ 2003.

## Guarantee Jaminan 保证

Every Makita tool is thoroughly inspected and tested before leaving the factory. It is guaranteed against defective workmanship and materials. Should any trouble develop, return the COMPLETE tool prepaid to Makita or point of purchase. If inspection shows trouble is caused by defective workmanship of material, all repairs will be made without charge. The guarantee does not apply where repairs have been made or attempted by others; repairs are due to normal wear; the tool has been abused or in an accident; misuse is evident – caused by overloading the tool beyond its capacity, use of the tool after partial failure or use with improper accessories.



# Makita Malaysia



Scan for our location  
Press untuk lokasi kami  
扫描位置地址

Makita Corporation was founded in 1915 as an electric motor sales and repair company. Makita has grown to become Japan's top manufacturer of portable power tools and recognized leader globally. In May 2013, Makita Malaysia Sales Subsidiary was established in Subang Jaya to provide the best service to cater and satisfy the increased demand and needs of Makita product range in the market. As a cordless tools company, we have the widest range of DC Cordless tools in the market. We envisioned a zero emission working environment with our wide range of DC Cordless Outdoor Power Equipment (DC Cordless OPE), as well as a clean and dustless working environment through our wide range of DC Cordless Cleaner & Vacuum Series. Utilizing the Compact eXtreme Technology (CXT) and Lithium-Ion eXtreme Technology (LXT) in our wide range of DC Cordless tools brings superb and durable performance for professional needs.

Makita Corporation ditubuhkan pada tahun 1915 sebagai syarikat jualan dan pembaikan motor elektrik. Makita telah berkembang menjadi pengilang utama alat-alat kuasa mudah alih dan pemimpin diiktiraf di peringkat global. Pada bulan Mei 2013, Subsidi Jualan Makita Malaysia ditubuhkan di Subang Jaya untuk menyediakan perkhidmatan terbaik untuk memenuhi permintaan pengguna dan memenuhi keperluan produk Makita di pasaran. Sebagai sebuah syarikat jualan peralatan tanpa kord, kami mengimpikan suasana kerja tanpa pencemaran melalui peralatan aktiviti kerja luar Lithium-ion (Li-ion OPE). Tambahan pula, ia menjadikan persekitaran kerja yang bersih dan tanpa habuk dengan Siri Peralatan Pembersihan kami. Teknologi eXtreme Compact (CXT) dan Teknologi Lithium-ion eXtreme (LXT) dicipta untuk alatan tanpa kord berprestasi tinggi dan tahan lama supaya memenuhi kehendak golongan profesional.

牧田公司成立于1915年，是一家电动机销售和维修公司。牧田已发展成为日本最大的便携式电动工具制造商，并且是全球公认的领导者。2013年5月，牧田马来西亚销售子公司在梳邦再也成立，以提供最佳服务以满足市场上对牧田产品不断增长的需求。通过一系列的锂电园林与户外工具 (Li-ion OPE)，我们致力于实现无排气的工作环境，我们的吸尘器系列，确保各类工业维持干净且无尘的工作环境。我们采用紧凑型极限技术 (CXT) 和锂离子技术 (LXT)，为专业需求打造高效率兼耐用性高的充电式工具。

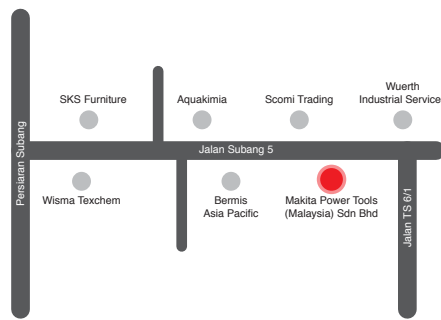

**HQ & Service Centre**  
总部和服务与展示中心  
Lot 824, Jalan Subang 5,  
Subang Industrial Area,  
47500 Subang Jaya, Selangor.  
Tel: 03-8023 0824 (General) | Fax: 03-8022 1448  
03-8022 1443 (Service)

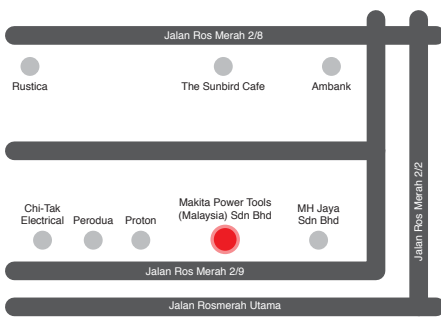

**Johor (Johor Bahru) Service Centre**  
柔佛 (新山) 服务与展示中心  
No. 12 & 14, Jalan Rosmerah 2/9,  
Taman Johor Jaya,  
81100 Johor Bahru, Johor.  
Tel: 07-364 9406 | Fax: 07-364 9407

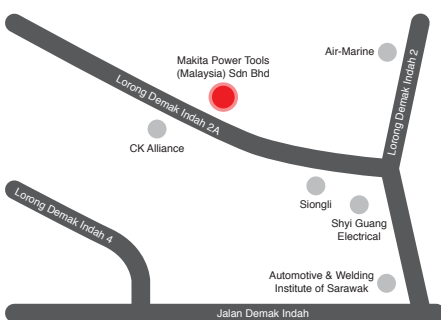

**Sarawak (Kuching) Service Centre**  
砂拉越 (古晋) 服务与展示中心  
Lot 1227, Lorong Demak Indah 2A,  
Demak Laut Industrial Area, Phase 2A,  
93050 Kuching, Sarawak.  
Tel: 082-496 800 | Fax: 082-496 900



**Sabah (Kota Kinabalu) Service Centre**  
沙巴 (亚庇) 服务与展示中心  
Lot 19, Jalan Buah Duku,  
Kolombong Light Industrial Estate,  
Off Kolombong, Kolombong Zone 1,  
88450 Inanam, Kota Kinabalu, Sabah.  
Tel: 088-388 278 | Fax: 088-388 279

# On-site Demo Service

Perkhidmatan demonstrasi mudah alih 流动示范服务

Our demo cars deliver comprehensive supporting services to customers. To serve customers who are not able to come to our showroom, our professional technical staff will drive the car to your working location. We will introduce products that fit your applications offer product demonstration and technical support according to your special needs. We can also teach you how to maintain your tools.

Kereta demo kami memberikan perkhidmatan sokongan yang komprehensif kepada pelanggan. Untuk memberi perkhidmatan kepada pelanggan yang tidak dapat datang ke bilik pameran kami, kakitangan teknikal profesional kami akan memandu kereta ke lokasi kerja anda. Kami akan memperkenalkan produk yang sesuai dengan aplikasi anda menawarkan demonstrasi produk dan sokongan teknikal mengikut keperluan khusus anda. Kami juga boleh mengajar anda bagaimana mengekalkan alat anda.

我们拥有流动示范服务车为客户提供全面的支持服务。为了协助未能到达我们的陈列室的客户提供服务，我们的专业技术人员会亲身到您的工作场地。我们将介绍适合您的产品，并根据您的特殊需求提供产品操作示范和技术支持。我们还可以教您如何保养牧田工具的方法等。

FOR ANY ENQUIRIES  
PLEASE CONTACT US ON  
**03-8023 0824**



# Road Show & Demonstration

Pameran demonstrasi 示范展销会

Come and join us at our roadshow for countless demonstrations on our latest tools and technologies. This is the perfect chance to find out more about our cordless solutions, be there to feel the extreme cordless power!

Datang dan sertai kami di roadshow kami untuk demonstrasi yang tidak terduga banyaknya mengenai alat dan teknologi terkini kami. Ini adalah peluang yang sempurna untuk mengetahui lebih lanjut mengenai penyelesaian tanpa wayar kami, berada di sana untuk merasai kuasa tanpa wayar yang melampau!

快来加入我们的展销会，以展示我们最新的电动工具与技术。这是一个了解更多有关我们的充电式工具解决方案的绝佳机会，在那里您将感受到无与伦比的充电式工具的功能！



# Health & Safety Seminar

Seminar Kesihatan & Keselamatan 健康安全讲座

Makita, as a responsible and professional supplier of power tools, always concerns about the health and safety issues of construction workers. Apart from developing products with specific safety features, we also organize seminars for various organizations to educate the workers on work safety and health.

Makita sebagai pembekal alat kuasa yang bertanggungjawab dan profesional, selalu membimbangkan tentang masalah kesihatan dan keselamatan pekerja pembinaan. Selain daripada membangunkan produk dengan ciri keselamatan tertentu, kami juga menganjurkan seminar untuk pelbagai organisasi untuk mendidik pekerja mengenai keselamatan kerja dan kesihatan.

牧田作为一家负责任的专业电动工具生产商，一直都很着重工人的健康及安全，并推出了一系列无线·无尘·无火花的工具。为帮助工人更深入地了解如何更安全、健康地工作，本公司会为不同团体或公司举办不同主题的讲座





# 12 MONTHS WARRANTY

## Waranti 12 bulan • 12个月保修期

\* Applicable on all Makita Tools, except heat gun (period of 6 months warranty)

\* Untuk semua Makita Tool, kecuali Heat Gun (waranti 6 bulan) | \*有效于所有 Makita 工具, 热风机除外 (享有6个月保修)

## Makita Standard Warranty

### Piawaian Waranti Makita • Makita 保修服务说明

Every Makita Product is thoroughly inspected and tested before leaving the factory. Subject to the following terms and conditions, the Product (Tool, Battery, Charger) is warranty against defective materials and manufacturing defects for a period of twelve (12) months from the date of purchase (applicable for purchases made from 1st October 2017 onwards) as evidenced from the sale or tax invoice (with tool serial number) and Makita Authorised Service Centre or Makita Service Centre undertakes, at our option, to repair or replace, free of charge.

#### Conditions of warranty

This warranty will NOT cover or shall be null & void in any of the following events even during the warranty period:-

1. Damage resulting from normal wear and tear (Carbon brush/ holder/ cap, switch, gear, grinding/ cutting wheels, bits, saw blades, etc.,)
2. Damage resulting from use of improper accessories, non genuine replacement parts, disassembly, tampering, alteration and repairing in any way that affects its performance.
3. Damage resulting from negligence, accident, disaster, improper storage or maintenance, abuse and misuse in evident caused by overloading the tool beyond its capacity.
4. Abnormal voltage or the usage of generator, wrong usage not in accordance with the Operating Manual.
5. If the serial number on the tool, seal on the battery and charger has been defaced or removed.
6. If the receipt or invoice that display the date of purchase could not be present.

Setiap produk Makita diperiksa dan diuji dengan teliti dari kilang. Waranti produk (Alat, Bateri, Pengcas Bateri) tertakluk kepada terma dan syarat berikut, sekiranya terdapat kecacatan pada bahan atau kerosakan disebabkan pembuatan dari kilang dalam tempoh 12 bulan bermula dari tarikh pembelian (untuk pembelian bermula dari 1hb Oktober 2017), dengan bukti pembelian pada resit atau invoice bercukai (dengan nombor siri alat), terikat kepada keputusan Pusat Servis diiktiraf oleh Makita atau Pusat Servis Makita untuk membaiki secara percuma.

#### Syarat-syarat waranti

Waranti ini TIDAK akan meliputi atau akan dibatalkan & tidak sah sekiranya berlaku salah satu kejadian yang berikut semasa berada dalam tempoh waranti:-

1. Kerosakan akibat daripada haus dan lusuh biasa (karbon/ pemegang/ tukup, suis, gear, cakera mencanai/ memotong, mata gerudi, bilah gergaji, dll.,)
2. Kerosakan akibat daripada penggunaan aksesori yang tidak sesuai, alat ganti yang tidak asli, pembukaan, perbuatan merosakkan, pengubahan dan pembaikan yang mempengaruhi prestasinya.
3. Kerosakan akibat kecuai, kemalangan, bencana, penyimpanan atau penyelenggaraan yang tidak wajar, penyalahgunaan yang jelas disebabkan oleh beban yang melebihi kemampuannya.
4. Voltan tidak normal atau penggunaan penjana, cara penggunaan yang salah dan tidak mengikut Manual Operasi.
5. Jika nombor siri pada alat, balu/ cap pada bateri dan pengcas tercacat atau ditanggalkan.
6. Jika resit atau invoice yang memaparkan tarikh pembelian tidak dapat ditunjukkan.

每个 Makita 产品生产制造都经过彻底检查和测试并严格把关确认品质。根据以下保修条件, 产品保修 (工具, 电池, 充电器) 涵盖材质和生产上的瑕疵, 于销售单据 (附上工具生产编号) 与税收发票上所显示的购买日期起十二 (12) 个月内 (从 1-10-2017 选购开始), 以 Makita 授权服务中心或 Makita 服务中心的判断为准而提供无收费维修。

#### 保修规定

Makita 均不承担基于以下违反保修行为而造成的产品故障、工作异常或损坏的责任。

1. 正常消耗零件。(例如: 碳刷/支架/盖, 开关, 齿轮, 研磨/切割片, 钻头, 锯片等)。
2. 使用不正确的配件, 更换非原装零件, 拆除和改造等任何影响其性能而引起的损坏。
3. 因人为疏忽, 意外, 灾难, 不正确的保管或保养, 滥用和误用, 超出工具负荷能力等原因导致的损坏。
4. 使用非工具所规定电压和发电机, 未按说明书安装及使用工具。
5. 工具上的编号, 电池和充电器上的印章已被污损或除去。
6. 无法提供销售单据或税收发票。

\*\* Makita reserved the rights of amend conditions of warranty without prior notice. In the event of differences arising between the English, Bahasa Malaysia and Chinese versions, the English version shall prevail.  
Makita berhak untuk meminda syarat-syarat waranti pada bila-bila masa tanpa sebarang notis. Jika terdapat perbezaan antara bahasa, maka maklumat versi Bahasa Inggeris harus digunakan.  
Makita 保留修改保修规定的权利, 恕不另行通知。如果内容有任何差异或不一致, 概以英文版本为准。



### Please visit our website for Authorised Service Centre details

Sila layari laman web kami untuk maklumat Pusat Servis Diiktiraf

请游览我们的网页查询授权服务中心详情

[www.makita.my/authorised-service-center](http://www.makita.my/authorised-service-center)

**SERVICES • SERVIS • 客户服务**  
[www.makita.my/authorised-service-center](http://www.makita.my/authorised-service-center)

**PRODUCT RANGE • RANGKAIAN PRODUK • 产品系列**  
[www.makita.my/product-range](http://www.makita.my/product-range)

**ACCESSORIES • AKSESORI • 配件**  
[www.makita.my/accessories-range](http://www.makita.my/accessories-range)

**PROMOTION • PROMOSI • 优惠**  
[www.makita.my/promotions](http://www.makita.my/promotions)

**ABOUT US • MENGENAI KAMI • 公司简介**  
[www.makita.my/about-us](http://www.makita.my/about-us)

**LATEST INFO • INFO TERKINI • 最新情报**  
[www.makita.my/latest-news/](http://www.makita.my/latest-news/)



TRADEMARK | Tanda Dagangan | 商标



Tanda dagang di atas telah dipatenkan oleh Perbadanan Harta Intelek Malaysia. Makita Power Tools (Malaysia) Sdn. Bhd. berhak untuk mengambil tindakan undang-undang bagi mana-mana pelanggaran tanda dagang di atas, termasuk perkilangan, borong atau menjual sama ada mesin atau aksesori yang dicetak dengan tanda di atas tanpa mendapat kebenaran Makita Power Tools (Malaysia) Sdn. Bhd

上述商标已经在马来西亚知识产权公司办理注册专利。对于任何侵犯上述商标专用权之行为，包括未经许可制造，批发或零售附有上述商标之电动工具及配件，本公司必定追究法律责任。

Above trademarks have been patented at the Intellectual Property Corporation of Malaysia. Makita Power Tools (Malaysia) Sdn. Bhd. reserves the right to take legal action for any infringement of the above trademarks, including manufacturing, wholesale or selling either the power tools or accessories printed with the above trademarks without getting permission of Makita Power Tools (Malaysia) Sdn. Bhd.

\*In the event of differences arising between the English, Bahasa Malaysia and Chinese versions, the English version shall prevail.

Jika terdapat perbezaan antara bahasa, maka maklumat versi Bahasa Inggeris harus digunapakai. 如果内容有任何差异或不一致，概以英文版本为准。

\*Items of standard equipment and specifications may vary by country or area. Net weight and dimensions may differ depending on the type of battery(ies) used. All pictures shown are for illustration purposes only.

Spesifikasi standard mungkin berbeza mengikut negara. Berat bersih dan dimensi berbeza bergantung pada jenis bateri yang digunakan. Imej yang ditunjukkan hanya untuk tujuan ilustrasi sahaja. 注：规格可能因销往国家之不同而异。重量与尺寸因附件(包括电池组)而异。图片仅供参考。



Makita Power Tools (Malaysia) Sdn. Bhd. Co. Registration No.: 201301001778 (1031615-M)

HQ & Service Centre  
总部和服务与展示中心

Lot 824, Jalan Subang 5, Subang Industrial Area,  
47500 Subang Jaya, Selangor.  
Tel: 03-8023 0824 (General) | Fax: 03-8022 1448  
03-8022 1443 (Service)

Johor (Johor Bahru) Service Centre  
柔佛(新山)服务与展示中心

No.12 & 14, Jalan Rosmerah 2/9,  
Taman Johor Jaya,  
81100 Johor Bahru, Johor.  
Tel: 07-364 9406 | Fax: 07-364 9407

Sarawak (Kuching) Service Centre  
砂拉越(古晋)服务与展示中心

Lot 1227, Lorong Demak Indah 2A,  
Demak Laut Industrial Area, Phase 2A,  
93050 Kuching, Sarawak.  
Tel: 082-496 800 | Fax: 082-496 900

Sabah (Kota Kinabalu) Service Centre  
沙巴(亚庇)服务与展示中心

Lot 19, Jalan Buah Duku,  
Kolombong Light Industrial Estate, Off Kolombong,  
Kolombong Zone 1, 88450 Inanam, Kota Kinabalu, Sabah.  
Tel: 088-388 278 | Fax: 088-388 279



www.makita.my  
makita@makita.my